

# TM 9-2320-363-10

---

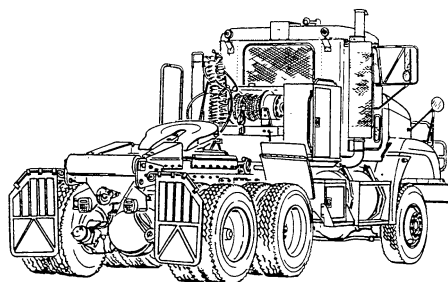
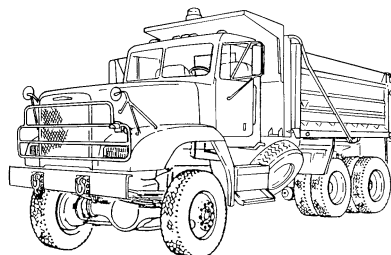
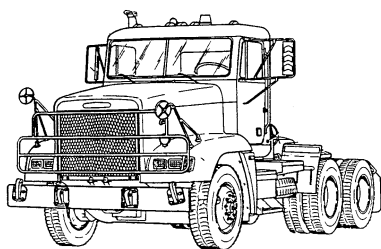
## OPERATOR'S MANUAL FOR

**TRUCK, TRACTOR, LINE HAUL:  
52,000 GVWR, 6 X 4, M915A2  
(NSN 2320-01-272-5029) (EIC: B4E)**

**TRUCK, TRACTOR, LIGHT EQUIPMENT TRANSPORTER (LET):  
68,000 GVWR, 6 X 6, W/WINCH, M916A1  
(NSN 2320-01-272-5028) (EIC: B4F)**

**TRUCK, TRACTOR, LIGHT EQUIPMENT TRANSPORTER (LET):  
68,000 GVWR, 6 X 6, W/WINCH, M916A2  
(NSN 2320-01-431-1163) (EIC: B4J)**

**TRUCK, DUMP, HEAVY, CHASSIS:  
68,000 GVWR, 6 X 6, 14 CU YD, ON-OFF HIGHWAY  
M917A1 (NSN 3805-01-431-1165) (EIC: E5C)  
M917A1 W/MCS (NSN 3805-01-432-8249) (EIC: EBD)**



Approved for public release; distribution is unlimited.

---

**HEADQUARTERS, DEPARTMENT OF THE ARMY**

**DECEMBER 1997**



**FOR INFORMATION ON FIRST AID, REFER TO FM 4-25.11.**

**WARNING**

**CARBON MONOXIDE (EXHAUST GASES) CAN KILL!**

Carbon monoxide is a colorless, odorless, deadly poison which, when breathed, deprives the body of oxygen and causes suffocation. Exposure to air containing carbon monoxide produces symptoms of headache, dizziness, loss of muscular control, apparent drowsiness, and coma. Permanent brain damage or death can result from severe exposure.

Carbon monoxide occurs in exhaust fumes of internal combustion engines. Carbon monoxide can become dangerously concentrated under conditions of inadequate ventilation. The following precautions must be observed to ensure safety of personnel when engine of truck is operated.

1. DO NOT operate truck engine in enclosed areas.
2. DO NOT idle truck engine without adequate ventilation.
3. DO NOT drive truck with inspection plates or cover plates removed.
4. BE ALERT for exhaust poisoning symptoms. They are:
  - Headache
  - Dizziness
  - Sleepiness
  - Loss of muscular control
5. If you see another person with exhaust poisoning symptoms:
  - Remove person from area.
  - Expose to fresh air.
  - Keep person warm.
  - Do not permit physical exercise.
  - Administer cardiopulmonary resuscitation (CPR), if necessary.
  - Notify a medic.
6. BE AWARE. The field protective mask for nuclear-biological-chemical (NBC) protection will not protect you from carbon monoxide poisoning.

***The Best Defense Against Carbon Monoxide Poisoning Is Good Ventilation!***

**WARNING**

**BATTERIES**

- To avoid eye injury, eye protection is required when working around batteries. Do not smoke, use open flame, make sparks, or create other ignition sources around batteries. If a battery is giving off gases, it can explode and cause injury to personnel. Remove all jewelry such as rings, ID tags, watches, and bracelets. If jewelry or a tool contacts a battery terminal, a direct short will result in instant heating, damage to equipment, and injury to personnel.
- Sulfuric acid contained in batteries can cause serious burns. If battery corrosion or electrolyte makes contact with skin, eyes, or clothing, take immediate action to stop the corrosive burning effects. Failure to follow these procedures may result in death or serious injury to personnel.
  - a. Eyes. Flush with cold water for no less than 15 minutes and seek medical attention immediately.
  - b. Skin. Flush with large amounts of cold water until all acid is removed. Seek medical attention as required.
  - c. Internal. If corrosion or electrolyte is ingested, drink large amounts of water or milk. Follow with milk of magnesia, beaten egg, or vegetable oil. Seek medical attention immediately.
  - d. Clothing/Equipment. Wash area with large amounts of cold water. Neutralize acid with baking soda or household ammonia.

**WARNING**

**BRAKES**

- Do not use trailer handbrake to prevent trailer from jackknifing because this may cause trailer to jackknife. Modern airbrake systems are designed to deliver the right amount of air to all wheels to stop vehicle without jackknifing. Failure to follow this warning may result in death or injury to personnel or damage to equipment.
- Do not use trailer handbrake as primary brake to keep tension on coupling system. This will cause undue tension on brakes and coupling which could result in injury to personnel or damage to equipment. Prevent problems with slack in fifth wheel by using good braking habits and adjusting coupling and braking systems properly.
- When caging brakes, block wheels to keep truck from moving when brakes are released. Failure to follow this warning may result in death or injury to personnel or damage to equipment.

**b**

- DO NOT use engine brake if road surfaces are slippery. Use of engine brake on wet, icy, or snow-covered roads could result in loss of vehicle control. Failure to follow this warning could result in death or injury to personnel or damage to equipment.
- Brake chamber contains spring under great pressure. To prevent personnel injury, never work directly behind chamber. If caging bolt will not engage properly, spring may be broken.
- Do not remove clamp ring around spring brake chamber. It is under tension and can cause personnel injury if released.
- When spring brakes are applied, vehicle will stop quickly which could result in injury to personnel. Also, vehicle cannot be driven again until malfunction is repaired and enough air supply is present for operation of service brakes.

**WARNING**

**COMPRESSED AIR**

Compressed air used for cleaning or drying purposes, or for clearing restrictions, should never exceed 30 psi (207 kPa). Wear protective clothing (goggles/shield, gloves, etc.) and use caution to avoid injury to personnel.

**WARNING**

**CTIS OPERATION (M917A1 AND M917A1 W/MCS)**

- When resuming operation on highway surfaces, be sure to reset CTIS selector panel to higher tire pressures. Operating vehicle with underinflated tires will cause premature tire wear or damage to tires causing unsafe driving conditions. Failure to follow this warning may result in death or injury to personnel.
- Always wear eye protection and drain all air from wet tank before disconnecting CTIS air lines, hoses or fittings. Residual air in tire(s) and air line(s) will be expelled even though tire(s) is flat. Failure to follow this warning could cause serious eye injury.

**WARNING**

**DIESEL FUEL HANDLING**

- DO NOT smoke or permit any open flame in area of truck while you are servicing diesel fuel system. Be sure hose nozzle is grounded against filler tube during refueling to prevent static electricity. Failure to follow this warning may result in injury to personnel or equipment damage.
- DO NOT perform fuel system checks, inspections, or maintenance while smoking or near fire, flames, or sparks. Fuel may ignite, causing damage to vehicle and injury or death to personnel.

- Fuel tank cap may become hot during vehicle operation. Use hand protection when removing fuel cap.

**WARNING**

**DRY CLEANING SOLVENT**

Dry cleaning solvent, P-D-680, is toxic and flammable. Always wear protective goggles and gloves, and use only in a well-ventilated area. Avoid contact with skin, eyes, and clothes, and DO NOT breathe vapors. DO NOT use near open flame or excessive heat. The solvent's flash point is 100°F-138°F (38°C-59°C). If you become dizzy while using cleaning solvent, immediately get fresh air and medical help. If solvent contact eyes, immediately wash your eyes and get medical aid.

**WARNING**

**FIRE EXTINGUISHER**

Discharging large quantities of dry chemical fire extinguisher in the cab may result in temporary breathing difficulty during and immediately after the discharge event. If at all possible, discharge fire extinguisher from outside the cab. Ventilate cab thoroughly prior to reentry.

**WARNING**

**HAZARDOUS WASTE DISPOSAL**

When servicing this vehicle, performing maintenance, or disposing of materials such as engine coolant, transmission fluid, lubricants, battery acids or batteries, and CARC paint, consult your unit/local hazardous waste disposal center or safety office for local regulatory guidance. If further information is needed, please contact The Army Environmental Hotline at 1-800-872-3845.

**WARNING**

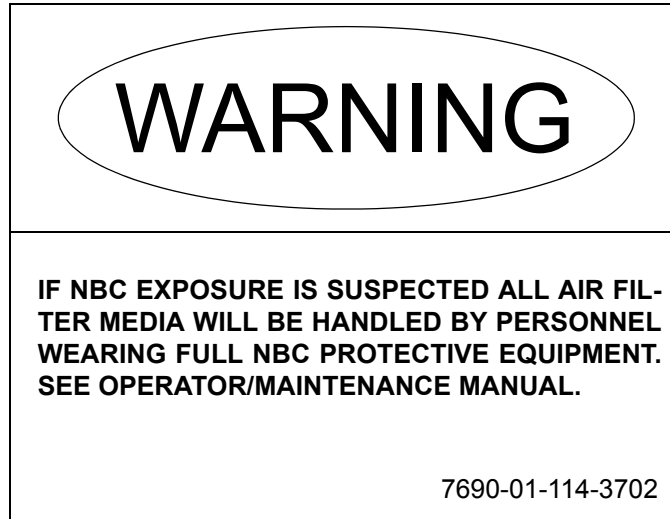
**HEARING PROTECTION**

Hearing protection is required when operating vehicle at more than 35 mph (56 kph) with windows open for an extended period of time. Hearing protection is also required when working around truck with engine running for an extended period of time, and when performing loading or dumping operations. Failure to follow this warning may result in hearing damage.

**WARNING**

**NBC EXPOSURE**

If NBC exposure is suspected, all air cleaner media should be handled by personnel wearing protective equipment. Consult your NBC Officer or NBC NCO for appropriate handling or disposal procedures.



**To order this NBC decal use:**

National Stock Number (NSN) - 7690-01-114-3702  
Part Number (PN) - 12296626  
Commercial and Government Entity Code (CAGEC) - 19207

**WARNING**

**PRESSURIZED COOLING AND HYDRAULIC SYSTEMS**

- DO NOT remove radiator cap unless engine is cold. Remove cap in two steps. First, place thick cloth over cap and slowly turn cap left to first stop. Pause and allow pressure to escape. Turn cap further left until it can be removed. This is a pressurized cooling system and escaping steam, hot water, or coolant will cause serious burns.
- DO NOT remove fill cap when hydraulic fluid is hot. Hydraulic tank is pressurized to 5 psi (34 kPa). Remove cap slowly to prevent serious burns.

**WARNING**

**SLAVE STARTING**

- When slave starting truck, use NATO slave cables that DO NOT have loose or missing insulation.
- DO NOT proceed if suitable cables are not available.
- DO NOT use civilian-type jumper cables.
- Failure to follow this warning could result in injury.

**WARNING**

**TIRE CHANGING**

Whenever inner and/or outer wheel lug nuts require tightening or a wheel has been removed and replaced, lug nuts must be torqued to the required torque. Failure to follow this warning may result in serious injury to personnel and damage to equipment.

**WARNING**

**TRUCK OPERATION**

- BE ALERT for personnel in area while operating truck. Always check to ensure area is clear of personnel and obstructions before moving out. Failure to follow this warning may result in serious injury or death to personnel.
- Use of seat belts while operating vehicle is mandatory. Fasten belt BEFORE driving. Trying to fasten three-point belt while driving creates a hazardous condition. Failure to follow this warning may result in death or injury to personnel.
- Serious injury may result if head clearance is not adequate while sitting in seat. Before driving or riding in vehicle, ensure there is adequate clearance at maximum upward travel of seat.
- Check Engine button is used for diagnostic purposes only. DO NOT push Check Engine button during vehicle operation because engine will slow down to an idle, which could cause hazardous operating conditions. Return to operating mode by releasing accelerator pedal and allowing engine to return to idle speed. Failure to follow this warning may result in death or injury to personnel.
- Use caution when coupling to or uncoupling from tractor truck. Be alert for personnel in area. Ensure that hands, arms, and body are clear of potential pinch points. Failure to follow this warning may result in injury to personnel.
- Operating truck with an underinflated or defective tire may lead to tire failure and loss of steering control. Damage to equipment or injury to personnel may result.
- These vehicles have been designed to operate safely and efficiently within the limits specified in this TM. Operation beyond these limits is prohibited in accordance with AR 70-1 without written approval from: Commander, U.S. Army Tank-automotive and Armaments Command, ATTN: AMSTA-DSA-CS, Warren, MI 48397-5000.



**WARNING**

**WINCH OPERATION (M916A1 AND M916A2)**

- Always wear heavy gloves when handling winch cable. Never allow cable to run through hands; frayed cable can cut you. Never operate winch with less than four turns of cable on drum. Keep cable coils tight and close together on drum while winching. Failure to follow this warning may result in injury to personnel.
- Hearing protection is required for operator and personnel working around winch station during operation.
- DO NOT use winch for moving or lifting people. Serious injury could result.

**WARNING**

**WORK SAFETY**

- Use caution when lifting or handling wheel and tire assembly. It is heavy and could cause injury if improperly lifted or if it falls on you.
- Hydraulic jack is intended only for lifting truck, not for supporting vehicle to perform maintenance. Do not get under truck after it is raised unless it is properly supported with blocks or jackstands. Failure to observe this warning may result in death or injury to personnel.
- Ether is highly flammable and explosive. DO NOT perform ether quick-start system checks or inspections while smoking or near fire, flame, or sparks. Failure to follow this warning may cause a fire and explosion, causing serious injury or death to personnel.
- Handle must be used when operating release lever. Failure to do so could result in injury to personnel.
- Failure to completely turn ON or OFF air cutoff valve will cause loss of brakes on trailer or truck.
- Lifting cables, chains, hooks, and slings used for lifting truck must be in good condition and of suitable capacity. Failure to follow this warning may result in injury or death to personnel and damage to equipment.
- Improper use of lifting equipment and improper attachment of cables to vehicle can result in serious personnel injury and equipment damage. Observe all standard rules of safety.

**WARNING**

**WATER DISTRIBUTOR TOWING**

- DO NOT tow 6,000 gallon water distributors with a partial load except when in use on construction sites and at a maximum speed of 10 mph. When towing outside of construction sites, either drain water distributor empty (preferred) or fill to capacity. Failure to follow this warning could result in unsafe driving conditions causing serious injury or death to personnel and damage to equipment.
- When towing 6,000 gallon water distributor, fifth wheel must be in rear setting (LOAD HAUL-172) and travel lockout must be engaged to prevent side-to-side oscillation of water distributor. Failure to follow this warning could result in unsafe driving conditions causing serious injury or death to personnel and damage to equipment.

CHANGE  
NO. 1

HEADQUARTERS  
DEPARTMENT OF THE ARMY  
Washington D.C., 15 February 2006

## OPERATOR'S MANUAL

**TRUCK, TRACTOR, LINE HAUL: 52,000 GVWR, 6 X 4, M915A2  
(NSN 2320-01-272-5029) (EIC: B4E)**

**TRUCK, TRACTOR, LIGHT EQUIPMENT TRANSPORTER (LET)  
68,000 GVWR, 6 X 6, W/WINCH, M916A1  
(NSN 2320-01-272-5028) (EIC: B4F)**

**TRUCK, TRACTOR, LIGHT EQUIPMENT TRANSPORTER (LET)  
68,000 GVWR, 6 X 6, W/WINCH, M916A2  
(NSN 2320-01-431-1163) (EIC: B4J)**

**TRUCK, DUMP, HEAVY, CHASSIS  
68,000 GVWR, 6 X 6, 14 CU YD, ON-OFF HIGHWAY  
M917A1 (NSN 3805-01-431-1165) (EIC: B5C)  
M917A1 W/MCS (NSN 3805-01-432-8249) (EIC: EBD)**

TM 9-2320-363-10, dated 30 December 1997, is changed as follows:

1. Remove old pages and insert new pages.
2. New or changed material is indicated by a vertical bar in the margin.

<b>Remove Pages</b>	<b>Insert Pages</b>
<i>A/B(Blank)</i>	<i>A and B</i>
<i>a thru h</i>	<i>a thru h</i>
<i>i and ii</i>	<i>i and ii</i>
<i>1-3 and 1-4</i>	<i>1-3 and 1-4</i>
<i>2-11 and 2-12</i>	<i>2-11 and 2-12</i>
<i>2-31 and 2-32</i>	<i>2-31 and 2-32</i>
<i>2-57 and 2-58</i>	<i>2-57 and 2-58</i>
<i>2-81 and 2-82</i>	<i>2-81 and 2-82</i>
<i>2-97 thru 2-98</i>	<i>2-97 thru 2-98</i>
<i>2-113 and 2-114</i>	<i>2-113 and 2-114</i>
<i>2-117 thru 2-119/(2-120 Blank)</i>	<i>2-117 thru 2-119/(2-120 Blank)</i>
<i>2-121 and 2-122</i>	<i>2-121 and 2-122</i>

Approved for public release; distribution is unlimited.

TM 9-2320-363-10

C1

**Remove Pages**

2-137 and 2-138

3-27 and 3-28

3-31 and 3-32

A-1 and A-2

B-3 thru B-8

C-1 and C-2

E-3 and E-4

Index 1 and Index 2

Index 5/(Index 6 Blank)

Front Cover

**Insert Pages**

2-137 and 2-138

3-27 and 3-28

3-31 and 3-32

A-1 and A-2

A-3/(A-4 Blank)

B-3 thru B-8

C-1 and C-2

E-3 and E-4

E-4.1/(E-4.2 Blank)

Index 1 and Index 2

Index 5/(Index 6 Blank)

Front Cover/Pin

3. File this change sheet in front of the publication for reference purposes.

By Order of the Secretary of the Army:

PETER J. SCHOOMAKER  
*General, United States Army*  
*Chief of Staff*

Official:



SANDRA R. RILEY

*Administrative Assistant to the  
Secretary of the Army*

0508908

**DISTRIBUTION:**To be distributed in accordance with the initial distribution number (IDN) 380850, requirements for TM 9-2320-363-10.

Approved for public release; distribution is unlimited.

**TM 9-2320-363-10**

**LIST OF EFFECTIVE PAGES**

Dates of issue for original and change pages/work packages are:

Original            30 December 1997  
Change 1           15 February 2006

TOTAL NUMBER OF PAGES FOR FRONT AND REAR MATTER IS 42 AND TOTAL NUMBER OF PAGES IS 306 CONSISTING OF THE FOLLOWING:

<b>Page No.</b>	<b>*Change No.</b>
Cover (Back Blank)	1
a to h	1
A and B	1
i and ii	1
iii/(iv Blank)	0
1-1 and 1-2	0
1-3	1
1-4 thru 1-37/(1-38 Blank)	0
2-1 thru 2-10	0
2-11	1
2-12 thru 2-30	0
2-31	1
2-32 thru 2-80	0
2-81	1
2-82 thru 2-96	0
2-97	1
2-97.0 and 2-97.1	1
2-98 thru 2-117	0
2-118 thru 2-119/(2-120 Blank)	1
2-121	0
2-122	1
2-123 thru 2-137	0
2-138	1
2-139 and 2-140	0
3-1 thru 3-27	0
3-28	1
3-29 thru 3-31	0
3-32	1
3-33 thru 3-39/(3-40 Blank)	0
A-1	1
A-2	0
A-3/(A-4 Blank)	1
B-1 and B-2	0

\* Zero in this column indicates an original page or work package.

TM 9-2320-363-10

<b>Page No.</b>	<b>*Change No.</b>
B-3 and B-4	1
B-5	0
B-6 thru B-8	1
C-1	0
C-2	1
C-3/(C-4 Blank)	0
D-1 thru D-5/(D-6 Blank)	0
E-1 thru E-3	0
E-4	1
E-4.1/(E-4.2 Blank)	1
E-5 thru E-9/(E-10 Blank)	0
F-1 thru F-17/(F-18 Blank)	0
Index -1	0
Index-2	1
Index-3 and Index-4	0
Index-5/(Index-6 Blank)	1
Authentication Page (Back Blank)	0
Sample DA Form 2028-2	0
Blank DA Form 2028-2	0
Blank Back Cover	0
Back Cover/PIN Number	1

\* Zero in this column indicates an original page or work package.

TECHNICAL MANUAL  
TM 9-2320-363-10

HEADQUARTERS  
DEPARTMENT OF THE ARMY  
Washington D.C., 30 December 1997

OPERATOR'S MANUAL  
FOR  
TRUCK, TRACTOR, LINE HAUL:  
52,000 GVWR, 6 X 4, M915A2  
(NSN 2320-01-272-5029) (EIC: B4E)

TRUCK, TRACTOR, LIGHT EQUIPMENT TRANSPORTER (LET):  
68,000 GVWR, 6 X 6, W/WINCH, M916A1  
(NSN 2320-01-272-5028) (EIC: B4F)

TRUCK, TRACTOR, LIGHT EQUIPMENT TRANSPORTER (LET):  
68,000 GVWR, 6 X 6, W/WINCH, M916A2  
(NSN 2320-01-431-1163) (EIC: B4J)

TRUCK, DUMP, HEAVY, CHASSIS:  
68,000 GVWR, 6 X 6, 14 CU YD, ON-OFF HIGHWAY  
M917A1 (NSN 3805-01-431-1165) (EIC: E5C)  
M917A1 W/MCS (NSN 3805-01-432-8249) (EIC: EBD)

**REPORTING ERRORS AND RECOMMENDING IMPROVEMENTS**

You can help improve this publication. If you find any mistakes or if you know of a way to improve the procedures, please let us know. Submit your DA Form 2028 (*Recommended Changes to Equipment Technical Publications*), through the Internet, on the Army Electronic Product Support (AEPS) website. The Internet address is <https://aeps.ria.army.mil/>. The DA Form 2028 is located under the Public Applications section in the AEPS Public Home Page. Fill out the form and click on SUBMIT. Using this form on the AEPS will enable us to respond quicker to your comments and better manage the DA Form 2028 program. You may also mail, fax or e-mail your letter or DA Form 2028 direct to: AMSTA-LC-LMIT/TECH PUBS, TACOM-RI, 1 Rock Island Arsenal, Rock Island, IL 61299-7630. The e-mail address is: TACOM-TECH-PUBS@ria.army.mil. The fax number is DSN 793-0726 or Commercial (309) 782-0726.

DISTRIBUTION STATEMENT A: Approved for public release; distribution is unlimited.

TABLE OF CONTENTS

		<b>Page</b>
CHAPTER 1	INTRODUCTION.....	1-1
Section I.	General Information.....	1-1
Section II.	Equipment Description and Data.....	1-5
Section III.	Principles of Operation.....	1-25
CHAPTER 2	OPERATING INSTRUCTIONS.....	2-1
Section I.	Description and Use of Operator's Controls and Indicators.....	2-1
Section II.	Preventive Maintenance Checks and Services (PMCS).....	2-33
Section III.	Operation Under Usual Conditions.....	2-81
Section IV.	Operation Under Unusual Conditions.....	2-121
CHAPTER 3	OPERATOR MAINTENANCE.....	3-1
Section I.	Lubrication Instructions.....	3-1
Section II.	Operator Troubleshooting Procedures.....	3-3
Section III.	Operator Maintenance.....	3-17
APPENDIX A	REFERENCES.....	A-1
APPENDIX B	COMPONENTS OF END ITEM AND BASIC ISSUE ITEMS LISTS.....	B-1
APPENDIX C	ADDITIONAL AUTHORIZATION LIST.....	C-1
APPENDIX D	EXPENDABLE AND DURABLE ITEMS LIST.....	D-1
APPENDIX E	STOWAGE AND DECAL, DATA PLATE, AND STENCIL GUIDE.....	E-1
APPENDIX F	LUBRICATION INSTRUCTIONS.....	F-1
	INDEX.....	Index 1



## HOW TO USE THIS MANUAL

This manual is designed to help you operate and maintain the M915 Family of Vehicles.

### FEATURES OF THIS MANUAL:

- A table of contents is provided at the beginning of this manual. An index of all paragraphs contained within a section is found at the beginning of each section.
- WARNINGS, CAUTIONS, NOTES, subject headings, and other important information are highlighted in **BOLD** print as a visual aid.

#### WARNING

**A WARNING indicates a hazard which can result in death or serious injury.**

#### CAUTION

**A CAUTION is a reminder of safety practices or directs attention to usage practices that may result in damage to equipment.**

#### NOTE

**A NOTE is a statement containing information that will make the procedure easier to perform.**

- Statements and words of particular importance are printed in CAPITAL LETTERS to create emphasis.
- Instructions are located with illustrations that show the specific task on which the operator is working.
- Dashed leader lines used in illustrations indicate that called out items are not visible (i.e., they are located within the structure). Dashed leader lines in the Lubrication Chart indicate that lubrication is required on BOTH sides of the equipment.
- Technical instructions include metric units in addition to standard units. A metric conversion chart is provided on the inside back cover.
- An alphabetical index is provided at the end of the manual to assist in locating information not readily found in the table of contents.

### FOLLOW THESE GUIDELINES WHEN YOU USE THIS MANUAL:

- Read through this manual and become familiar with its contents before attempting to operate or maintain the truck.
- A warning summary is provided at the beginning of this manual and should be read before attempting to operate or maintain the truck.



# CHAPTER 1 INTRODUCTION

---

## Section I. GENERAL INFORMATION

Paragraph Number	Paragraph Title	Page Number
1-1.	Scope .....	1-1
1-2.	Maintenance Forms and Procedures .....	1-2
1-3.	Corrosion Prevention and Control (CPC) .....	1-2
1-4.	Destruction of Army Materiel to Prevent Enemy Use .....	1-2
1-5.	Reporting Equipment Improvement Recommendations (EIRs)	1-3
1-6.	Warranty Information .....	1-3
1-7.	Nomenclature Cross-Reference List .....	1-3
1-8.	List of Abbreviations .....	1-3

---

### 1-1. SCOPE.

---

a. **Type of Manual.**

(1) This manual is for use in operating and maintaining the M915 Family of Vehicles, to include the chassis of the M917A1 and M917A1 w/MCS (Material Control System) dump truck.

(2) For operation and maintenance of the M917A1 and M917A1 w/MCS dump truck body, refer to TM 5-3805-264-14&P.

b. **Equipment Name and Model Number.**

(1) Truck, Tractor, Line Haul: 52,000 GVWR, 6 X 4, M915A2

(2) Truck, Tractor, Light Equipment Transporter (LET): 68,000 GVWR, 6 X 6, w/Winch, M916A1 and M916A2

(3) Truck, Dump, Heavy, Chassis: 68,000 GVWR, 6 X 6, 14 Cu Yd, On-Off Highway, M917A1 and M917A1 w/MCS.

c. **Purpose of Equipment.**

(1) The M915A2 truck tractor is a 6 X 4 prime mover of semitrailers used primarily to transport containers, bulk cargo, and petroleum products over primary and secondary roads under worldwide climatic conditions in a military environment.

---

### **1-1. SCOPE (Con't).**

---

(2) The M916A1 and M916A2 truck tractors are 6 X 6 prime movers of low-bed semitrailers used primarily to transport heavy engineer equipment over primary and secondary roads, and off-road, under worldwide climatic conditions in a military environment.

(3) The M917A1 and M917A1 w/MCS are 6 X 6 dump trucks used to transport, dump, or spread asphalt, aggregate, dirt, and similar materials over primary and secondary roads and off-road.

---

### **1-2. MAINTENANCE FORMS AND PROCEDURES.**

---

Department of the Army forms and procedures used for the equipment will be those prescribed by DA Pam 738-750, *Functional User's Manual for the Army Maintenance Management System (TAMMS)*, as contained in the Maintenance Management Update.

---

### **1-3. CORROSION PREVENTION AND CONTROL (CPC).**

---

a. Corrosion Prevention and Control (CPC) of Army materiel is a continuing concern. It is important that any corrosion problems with this item be reported so that the problem can be corrected and improvements can be made to prevent the problem in future items.

b. While corrosion is typically associated with rusting of metals, it can also include deterioration of other materials, such as rubber and plastic. Unusual cracking, softening, swelling, or breaking of these materials may be a corrosion problem. If a corrosion problem is identified, it can be reported using SF Form 368 (*Product Quality Deficiency Report*). Use of key words such as "corrosion," "rust," "deterioration," or "cracking" will ensure that the information is identified as a CPC problem. The form should be submitted to the address specified in DA Pam 738-750.

---

### **1-4. DESTRUCTION OF ARMY MATERIEL TO PREVENT ENEMY USE.**

---

For destruction of Army materiel to prevent enemy use, refer to TM 750-244-6.

---

**1-5. REPORTING EQUIPMENT IMPROVEMENT RECOMMENDATIONS (EIRs).**

---

If your truck needs improvement, let us know. Send us an EIR. You, the user, are the only one who can tell us what you don't like about your equipment. Let us know why you don't like the design or performance. Put it on an SF Form 368 (*Product Quality Deficiency Report*). Mail it to us at: Commander, U.S. Army Tank-automotive and Armaments Command, ATTN: AMSTA-AC-NML, Rock Island, Illinois 61299-7630. We'll send you a reply.

---

**1-6. WARRANTY INFORMATION.**

---

The vehicles are warranted by Freightliner Corporation in accordance with TB 9-2320-363-15. Warranty starts on the date found in block 23, DA Form 2408-9 in the logbook. Report all defects in material or workmanship to your supervisor, who will take appropriate action through your Unit Maintenance shop.

---

**1-7. NOMENCLATURE CROSS-REFERENCE LIST.**

---

<b>Common Name</b>	<b>Official Nomenclature</b>
Cable . . . . .	Wire Rope
Cold Start System . . . . .	Ether Quick-Start System
Differential Lock/Unlock. . . . .	Interaxle Lockout (M915A2), All-Wheel Drive (All Except M915A2)
Engine Coolant . . . . .	Antifreeze, Ethylene Glycol Mixture
Gladhand . . . . .	Quick Disconnect Coupling
Jake Brake . . . . .	Engine Brake
Komfort Loc® . . . . .	Seat Belt Adjustment
No Spin® . . . . .	Automatic Locking Positive Traction Differential

---

**1-8. LIST OF ABBREVIATIONS.**

---

**NOTE**

**Refer to ASME Y14.38-1999 for standard abbreviations.**

<b>Abbreviation</b>	<b>Definition</b>
AAL . . . . .	Additional Authorization List
ABS . . . . .	Anti-Lock Brake System
BII . . . . .	Basic Issue Items
C . . . . .	Centigrade or Celsius

---

**1-8. LIST OF ABBREVIATIONS (Con't).**

---

<b>Abbreviation</b>	<b>Definition</b>
CID .....	Cubic Inch Displacement
cm .....	Centimeter
COEI .....	Components of End Item
CTIS .....	Central Tire Inflation System
ECU .....	Electronic Control Unit
F .....	Fahrenheit
GCWR .....	Gross Combination Weight Rating
GVWR .....	Gross Vehicle Weight Rating
kg .....	Kilogram
kph .....	Kilometers per Hour
lph .....	Liters per Hour
MCS .....	Material Control System
PMCS .....	Preventive Maintenance Checks and Services
PTO .....	Power Take-Off

## Section II. EQUIPMENT DESCRIPTION AND DATA

Paragraph Number	Paragraph Title	Page Number
1-9.	Equipment Characteristics, Capabilities, and Features . . . .	1-5
1-10.	Location and Description of Major Components. . . . .	1-6
1-11.	Differences Between Models . . . . .	1-15
1-12.	Equipment Data . . . . .	1-16

### 1-9. EQUIPMENT CHARACTERISTICS, CAPABILITIES, AND FEATURES.

a. **Characteristics.**

(1) The M915A2 is used to transport M871, M872, and M1062 semitrailers on line haul missions. It has a Gross Vehicle Weight Rating (GVWR) of 52,000 lb (23,608 kg) and is equipped with a two-way oscillating, sliding fifth wheel compatible with a two-inch kingpin. Maximum towed load on kingpin is 30,000 lb (13,620 kg).

(2) The M916A1 and M916A2 are used to transport M172 and M870 semitrailers loaded with heavy engineer equipment and 60PRS and WD6S 6,000 gallon water distributors over primary and secondary roads and off-road. They have a GVWR of 68,000 lb (30,872 kg) and are equipped with a 45,000 lb (20,430 kg) winch, a tail roller, and a four-way oscillating, sliding fifth wheel compatible with a 3 1/2-inch kingpin. Maximum towed load on kingpin is 40,000 lb (18,160 kg).

(3) The M917A1 and M917A1 w/MCS have a GVWR of 68,000 lb (30,872 kg), a 14 cu yd (10.7 m<sup>3</sup>) dump body capacity, and an 18.5 ton (16.8 metric ton) load capability. They are equipped with a Central Tire Inflation System (CTIS) which allows operation across a wide variety of terrain.

b. **Capabilities and Features.**

(1) While operating on Class I roads, the fully loaded M915A2 can maintain a speed of 55 mph (88 kph) on level roads and 29 mph (47 kph) while ascending a 3 percent grade. It has a minimum turning diameter, curb-to-curb, of 53 ft 9 in. (16.4 m).

(2) While operating on Class I roads, all other trucks can maintain a speed of 55 mph (88 kph) on level roads and 25 mph (40 kph) while ascending a 3 percent grade.

(3) Average cruising ranges at Gross Combination Weight Rating (GCWR) with a full tank of fuel will vary based on conditions (e.g., varying loads, prolonged idle, PTO usage, off-road driving, and climatic conditions). Cruising range is optimally 300 miles (483 km).

---

**1-9. EQUIPMENT CHARACTERISTICS, CAPABILITIES, AND FEATURES (Con't).**

---

(4) The M916A1 and M916A2 have a transmission-mounted PTO which powers the winch. The PTO on the M917A1 and M917A1 w/MCS powers the dump body controls (TM 5-3805-264-14&P).

(5) The M915A2 and M916A1 are equipped with an instrument panel mounted tachograph which registers and records data related to truck ground speed, engine speed, and distance traveled. This data is stored on a 7-day graph for a permanent record. All other models are equipped with a Datalogger which is a data processing module that provides data storage capability and records in detail the performance and utilization of the vehicle. Datalogger memory can store over a month of data for use by maintenance and management personnel. There is no operator interference with the Datalogger.

(6) The following capabilities and features are common to all models:

(a) air-activated front and rear non-asbestos cam brakes with a four-channel anti-lock brake system (ABS) to provide significantly improved handling and braking during emergency stops;

(b) operation in temperatures from -25°F (-32°C) to +125°F (+52°C), and to -40°F (-40°C) with arctic kit installed;

(c) start and climb capability of a 20 percent grade at GCWR in both forward and reverse directions;

(d) fording capability up to 20 in. (51 cm) deep for 5 minutes without damage or requiring maintenance before operations can continue;

(e) two-passenger aluminum corrosion-proof cab with a 90 degree tilt-forward hood for service accessibility;

(f) six cylinder, 12.7 liter, 400 horsepower, in-line diesel engine built by Detroit Diesel;

(g) Allison HT-740 four-speed automatic transmission.

---

**1-10. LOCATION AND DESCRIPTION OF MAJOR COMPONENTS.**

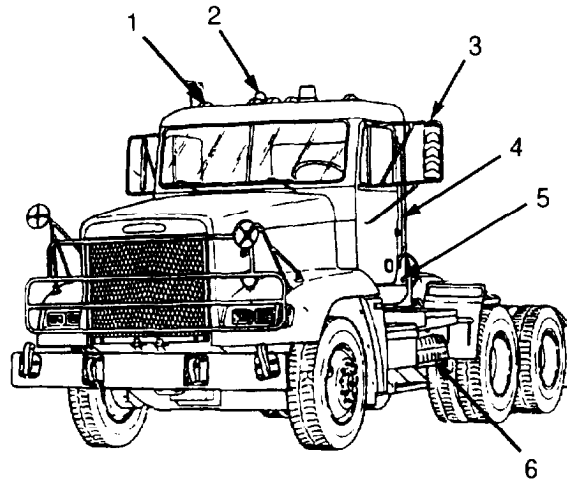
---

a. **M915A2, M916A1, and M916A2.**

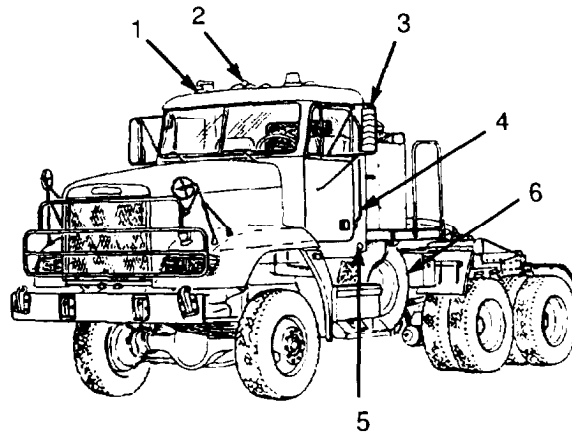
Key	Component	Description
1	Marker Clearance Lights	Indicate outline of truck.
2	Air Horn	Provides an audible alert.



**1-10. LOCATION AND DESCRIPTION OF MAJOR COMPONENTS (Con't).**



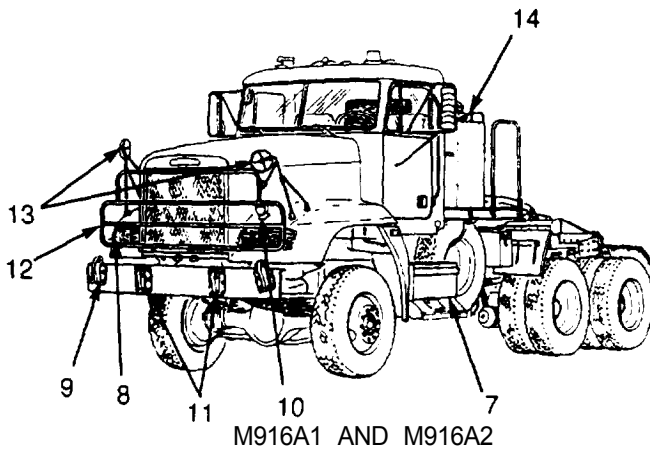
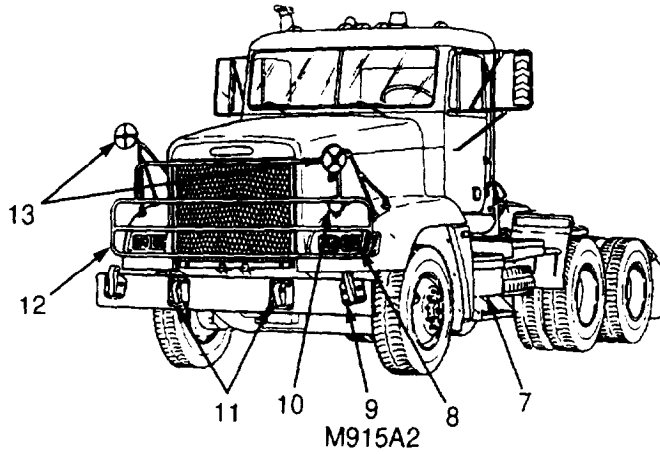
M915A2



M916A1 AND M916A2

Key	Component	Description
3	Side Mirrors	Provide driver with a view of sides of truck.
4	Grabhandles	Provide a hand hold for personnel climbing on truck.
5	Utility Power Receptacle	Supplies power for work lights. Located on both sides of truck.
6	Spare Wheel and Tire	Extra wheel and tire used in case of a flat tire.

**1-10. LOCATION AND DESCRIPTION OF MAJOR COMPONENTS (Con't).**



Key	Component	Description
7	Battery Box and Steps	Holds vehicle batteries and provides steps to access cab.
8	Front Service Lights	Include headlights and turn signals.
9	Sling Points	Provide attachment point for slings.
10	Blackout Lights	Used during blackout conditions. Include marker and drive lights.

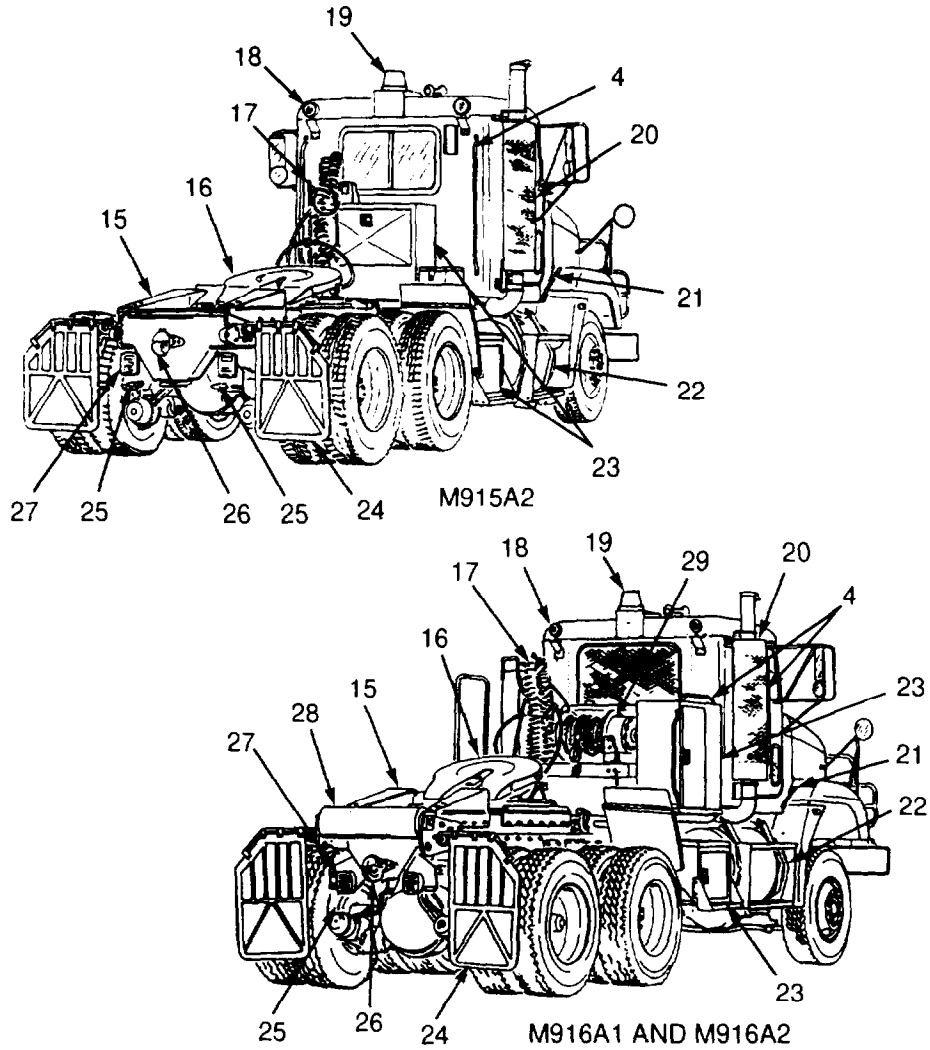
---

**1-10. LOCATION AND DESCRIPTION OF MAJOR COMPONENTS (Con't).**

---

<b>Key</b>	<b>Component</b>	<b>Description</b>
11	Towing Eyes	Provide attachment points for towing device.
12	Brush Guard	Protects front of hood and components under hood from damage.
13	Spotting Mirrors	Provide added visibility to sides of truck and semitrailer if towing.
14	Winch Controls (M916A1 and M916A2)	Operate winch.

**1-10. LOCATION AND DESCRIPTION OF MAJOR COMPONENTS (Con't).**



Key	Component	Description
4	Grabhandles	Provide a hand hold for personnel climbing on truck.
15	Ramp	Sloped surface serves as an approach to fifth wheel and facilitates coupling of semitrailer.
16	Fifth Wheel	Coupling device for semitrailers with kingpins.

---

**1-10. LOCATION AND DESCRIPTION OF MAJOR COMPONENTS (Con't).**


---

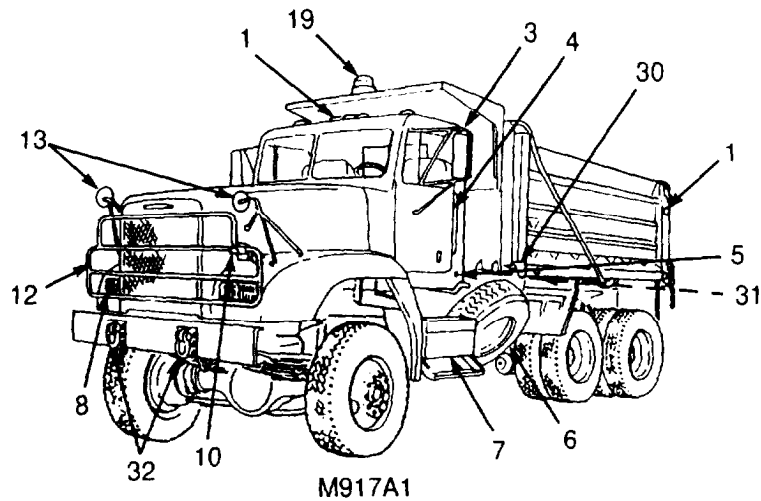
<b>Key</b>	<b>Component</b>	<b>Description</b>
17	Hosetenna	Mounting and stowage location for intervehicular air lines.
18	Utility Lights	Illuminate area in back of cab. There is one light on each side of cab.
19	Beacon Warning Light	Amber rotating light alerts other vehicles of presence of truck.
20	Exhaust Muffler	Deadens noise of engine exhaust.
21	Hood Latch	Locks hood closed. Located on both sides of hood.
22	Fuel Tank	Holds fuel. Steps mounted to tank provide access to cab.
23	Storage Boxes	Provide stowage area for BII and other items.
24	Mud Flaps	Prevent water and debris from spraying up on passers by or towed semitrailer.
25	Trailer Gladhands	Provide air supply for brakes of trailer.
26	Pintle Hook	Coupling device for trailers with lunettes.
27	Taillights	Contain composite tail, stop, backup, and turn signal lights.
28	Tail Roller (M916A1 and M916A2)	Facilitates coupling and uncoupling operations.
29	Hydraulic Winch (M916A1 and M916A2)	Powered by PTO to perform winching operations.

**1-10. LOCATION AND DESCRIPTION OF MAJOR COMPONENTS (Con't).**

b. **M917A1 and M917A1 w/MCS.**

**NOTE**

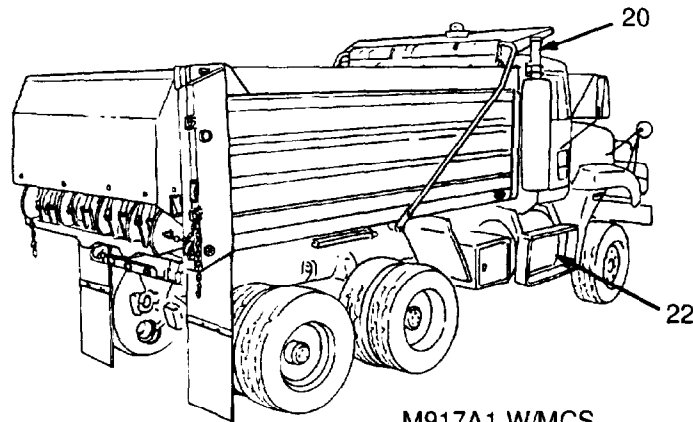
Refer to TM 5-3805-264-14&P for more information on the location and description of major components of the dump truck body.



Key	Component	Description
1	Marker Clearance Lights	Indicate outline of dump truck.
3	Side Mirrors	Provide driver with a view of sides of dump truck.
4	Grabhandles	Provide a hand hold for personnel climbing on dump truck.
5	Utility Power Receptacle	Supplies power for work lights. Located on both sides of dump truck.
6	Spare Wheel and Tire	Extra wheel and tire used in case of a flat tire.
7	Battery Box and Steps	Holds vehicle batteries and provides steps to access cab.
8	Front Service Lights	Include headlights and turn signals.
10	Blackout Lights	Used during blackout conditions.

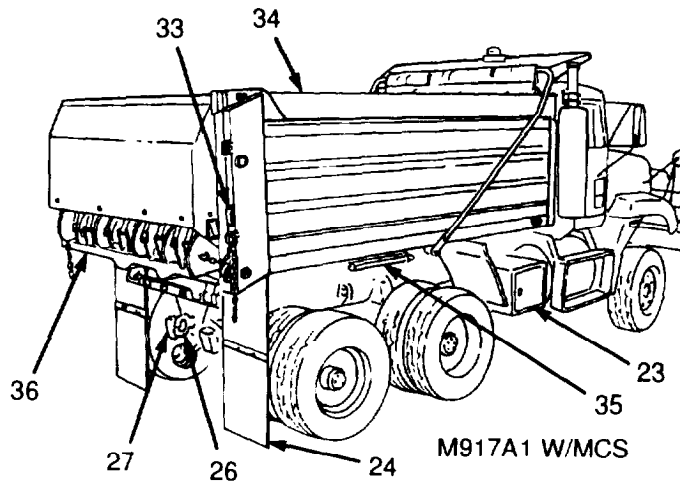
**1-10. LOCATION AND DESCRIPTION OF MAJOR COMPONENTS (Con't).**

Key	Component	Description
12	Brush Guard	Protects front of hood and components under hood from damage.
13	Spotting Mirrors	Provide added visibility to sides of truck and trailer if towing.
19	Beacon Warning Light	Amber rotating light alerts other vehicles of presence of truck.
30	Cargo Cover Controls	Extend and retract cargo cover.
31	Transport Lock	Locks dump body to truck frame when transporting dump truck.
32	Lift/Tie-Down Shackles	Provides lift and tie-down points.



Key	Component	Description
20	Exhaust Muffler	Deadens noise of engine exhaust.
22	Fuel Tank	Holds fuel. Steps mounted to tank provide access to cab.

**1-10. LOCATION AND DESCRIPTION OF MAJOR COMPONENTS (Con't).**



Key	Component	Description
23	Storage Box	Provides stowage area for BII and other items.
24	Mud Flaps	Prevent water and debris from spraying up on passers by or dump body.
26	Pintle Hook	Coupling device for trailers with lunettes.
27	Taillights	Composite tail, stop, backup, and turn signal lights on vehicle chassis.
33	Taillights (Dump Body)	Include tail, stop, and turn signal lights. Instead of backup lights, dump body has an audible backup warning signal.
34	Dump Body	Holds aggregate, hot mix asphalt, or similar materials.
35	Body Props	Used to support raised, EMPTY dump body for inspection and maintenance.
36	MCS Tailgate	Has four electro-pneumatically controlled gates which allow for controlled spreading of material. Can also operate like a standard tailgate.



**1-11. DIFFERENCES BETWEEN MODELS.**

Item	Vehicle Model			
	M915A2	M916A1	M916A2	M917A1/ M917A1 w/MCS
Engine Model DDEC II	X	X		
Engine Model DDEC III			X	X
Manual Ether Quick-Start	X	X	X*	X*
Automatic Ether Quick-Start			X	X
Transfer Case		X	X	X
Driving Front Axle		X	X	X
Highway Tires	X			
On/Off Road Tires		X	X	X
CTIS				X
Spare Wheel and Tire	X	X	X	X
2-Way Sliding Fifth Wheel	X			
4-Way Oscillating Fifth Wheel		X	X	
Hydraulic Winch		X	X	
Tachograph	X	X		
Datalogger			X	X
Air Conditioner			X	X

\*Initially-built M916A2 and M917A1/M917A1 w/MCS have manual ether quick-start system.

**1-12. EQUIPMENT DATA.**

**Table 1-1. Equipment Data.**

Data	Model			
	M915A2	M916A1	M916A2	M917A1/ M917A1 w/MCS
<b>Manufacturer</b>	Freightliner	Freightliner	Freightliner	Freightliner
<b>Dimensions:</b>				
Length (Overall)	275.5 in. (700 cm)	289 in. (734 cm)	289 in. (734 cm)	303.8 in. (771.7 cm)/ 316.8 in. (804.7 cm)
Height (Overall)	119 in. (302 cm)	128 in. (325 cm)	128 in. (325 cm)	135.5 in. (343 cm)
Width (Overall)	98 in. (249 cm)	98 in. (249 cm)	98 in. (249 cm)	103.8 in. (267 cm)
Wheelbase	162 in. (411 cm)	174 in. (442 cm)	174 in. (442 cm)	174 in. (442 cm)
Ground Clearance	9 in. (23 cm)	9 in. (23 cm)	9 in. (23 cm)	9 in. (23 cm)
<b>Weights:</b>				
Curb	18,680 lb (8481 kg)	27,740 lb (12,594 kg)	27,860 (12,684 kg)	29,454/ 31,472 (13,360/ 14,288 kg)
GVWR	52,000 lb (23,608 kg)	68,000 lb (30,872 kg)	68,000 lb (30,872 kg)	68,000 lb (30,872 kg)
GCWR	105,000 lb (46,670 kg)	130,000 lb (59,020 kg)	130,000 lb (59,020 kg)	68,000 lb (30,872 kg)
Front Axle (Loaded)	12,000 lb (5448 kg)	16,000 lb (7264 kg)	16,000 lb (7264 kg)	16,000 lb (7264 kg)
Rear Axle (Loaded)	40,000 lb (18,160 kg)	52,000 lb (23,608 kg)	52,000 lb (23,608 kg)	52,000 lb (23,608 kg)
<b>Angle of Approach</b>	27°	37.5°	37.5°	37.5°

**1-12. EQUIPMENT DATA (Con't).**

**Table 1-1. Equipment Data (Con't).**

Data	Model			
	M915A2	M916A1	M916A2	M917A1/ M917A1 w/MCS
<b>Capacities:</b>				
Engine Oil (Refill w/Filters)	41 qt (38.8 l)	41 qt (38.8 l)	41 qt (38.8 l)	41 qt (38.8 l)
Engine Oil Filter (Refill)	4 qt (3.8 l)	4 qt (3.8 l)	4 qt (3.8 l)	4 qt (3.8 l)
Engine Bypass Oil Filter (Refill)	1.4 qt (1.3 l)	1.4 qt (1.3 l)	N/A	N/A
Cooling System	65 qt (61.5 l)	65 qt (61.5 l)	65 qt (61.5 l)	65 qt (61.5 l)
Fuel Tank	80 gal. (302.8 l)	100 gal. (378.5 l)	100 gal. (378.5 l)	100 gal. (378.5 l)
Power Steering Reservoir	2 qt (1.9 l)	2 qt (1.9 l)	2 qt (1.9 l)	2 qt (1.9 l)
Winch Reservoir	N/A	42 gal. (159.0 l)	42 gal. (159.0 l)	N/A
Winch Drum	N/A	5 qt (4.7 l)	5 qt (4.7 l)	N/A
Front Axle	N/A	27 pt (12.8 l)	27 pt (12.8 l)	27 pt (12.8 l)
Transmission	33 qt (31.2 l)	33 qt (31.2 l)	33 qt (31.2 l)	33 qt (31.2 l)
Transfer Case	N/A	5 qt (4.7 l)	5 qt (4.7 l)	5 qt (4.7 l)
Rear Axle (Forward/Rear)	13/14.5 qt (12.3/13.7 l)	22/23 qt (20.8/21.8 l)	22/23 qt (20.8/21.8 l)	22/23 qt (20.8/21.8 l)
<b>Engine:</b>				
Manufacturer	Detroit Diesel	Detroit Diesel	Detroit Diesel	Detroit Diesel
Type	4-stroke, in- line diesel	4-stroke, in- line diesel	4-stroke, in- line diesel	4-stroke, in- line diesel

**1-12. EQUIPMENT DATA (Con't).**

Table 1-1. Equipment Data (Con't).

Data	Model			
	M915A2	M916A1	M916A2	M917A1/ M917A1 w/MCS
<b>Engine (Con't):</b>				
Model	DDEC II	DDEC II	DDEC II	DDEC III
Cylinders	6	6	6	6
Displacement	775 CID (12.7 l)	775 CID (12.7 l)	775 CID (12.7 l)	775 CID (12.7 l)
Torque @ 1200 rpm	1400 lb.-ft. (1898 N • m)	1400 lb.-ft. (1898 N • m)	1400 lb.-ft. (1898 N • m)	1400 lb.-ft. (1898 N • m)
Maximum Horsepower @ 2100 rpm	400 (298.3 kW)	400 (298.3 kW)	400 (298.3 kW)	400 (298.3 kW)
Maximum Governed Speed	2100 rpm	2100 rpm	2100 rpm	2100 rpm
<b>Oil Filter Type:</b>	DDEC II 1 bypass, 2 full flow, replaceable elements	DDEC II 1 bypass, 2 full flow, replaceable elements	DDEC III 2 full flow, replaceable elements	DDEC III 2 full flow, replaceable elements
<b>Oil Filter Quantity:</b>	3	3	2	2
<b>Fuel System:</b>				
Type	diesel fuel injected	diesel fuel injected	diesel fuel injected	diesel fuel injected
Fuel Tank:				
Type	cylinder	cylinder	cylinder	cylinder
Quantity	1	1	1	1
Air Cleaner:				
Type	dry element	dry element	dry element	dry element
Quantity	1	1	1	1

**1-12. EQUIPMENT DATA (Con't).**

**Table 1-1. Equipment Data (Con't).**

Data	Model			
	M915A2	M916A1	M916A2	M917A1/ M917A1 w/MCS
<b>Cooling System:</b> Radiator Working Pressure	10 psi (69 kPa)	10 psi (69 kPa)	10 psi (69 kPa)	10 psi (69 kPa)
<b>Electrical System:</b> Batteries: Quantity Voltage	dual 12/24 volt  4  12 volt	dual 12/24 volt  4  12 volt	dual 12/24 volt  4  12 volt	dual 12/24 volt  4  12 volt
<b>Transmission:</b> Manufacturer Model Type Shifter	Allison HT-470 4-speed automatic power shift	Allison HT-470 4-speed automatic power shift	Allison HT-470 4-speed automatic power shift	Allison HT-470 4-speed automatic power shift
<b>Transfer Case:</b> Manufacturer Type	N/A N/A	Oshkosh 2-speed	Oshkosh 2-speed	Oshkosh 2-speed
<b>Front Axle:</b> Manufacturer Type Rated Capacity Maximum Steering Angle	Rockwell I-beam, FF961 12,000 lb (5448 kg) 32°	Oshkosh Hypoid, FDS- 1807 16,000 lb (7264 kg) 28°	Oshkosh Hypoid, FDS 1807 16,000 lb (7264 kg) 28°	Oshkosh Hypoid, FDS- 1807 16,000 lb (7264 kg) 28°

**1-12. EQUIPMENT DATA (Con't).**

**Table 1-1. Equipment Data (Con't).**

Data	Model			
	M915A2	M916A1	M916A2	M917A1/ M917A1 w/MCS
<b>Rear Axle (Tandem):</b>				
Manufacturer	Rockwell RT40-145P	Rockwell RT52-160P	Rockwell RT52-160P	Rockwell RT52-160 w/ CTIS
Rated Capacity	40,000 lb (18,160 kg)	52,000 lb (23,608 kg)	52,000 lb (23,608 kg)	52,000 lb (23,608 kg)
Ratio	4.56:1	4.89:1	4.89:1	4.89:1
Automatic Locking Positive Traction Differential	forward- rear differential only	both rear differentials	both rear differentials	both rear differentials
<b>Brake System:</b>				
Actuation	Air-mechanical	Air-mechanical	Air-mechanical	Air-mechanical
Pressure Range	60-120 psi (414-827 kPa)	60-120 psi (414-827 kPa)	60-120 psi (414-827 kPa)	60-120 psi (414-827 kPa)
<b>Airbrake Chambers:</b>				
Service	2 on front axle	2 on front axle	2 on front axle	2 on front axle
Failsafe (Spring)	4 on forward-rear and rear-rear axles	4 on forward-rear and rear-rear axles	4 on forward-rear and rear-rear axles	4 on forward-rear and rear-rear axles
<b>ABS (Anti-Lock Brake System) :</b>				
Type	4-channel	4-channel	4-channel	4-channel
Location	front axle and rear-rear axle	front axle and rear-rear axle	front axle and rear-rear axle	front axle and rear-rear axle

**1-12. EQUIPMENT DATA (Con't).**

**Table 1-1. Equipment Data (Con't).**

Data	Model			
	M915A2	M916A1	M916A2	M917A1/ M917A1 w/MCS
<b>Wheels:</b>				
Size	22.5 x 8.25 in.	22.5 x 9 in.	22.5 x 9 in.	22.5 x 9 in.
Number of Studs/ Stud Size	10/1.125 in.	10/1.125 in.	10/1.125 in.	10/1.125 in.
<b>Tires:</b>				
Type	tubeless, radial on- highway	tubeless, radial on/off road	tubeless, radial on/off road	tubeless, radial on/off road
Size	11R22.5	80R22.5	80R22.5/ XZY-1	Front: 65R22.5/XZY Rear: 80R22.5/ XZY-1
Ply Rating	14PR	18PR	18PR	18PR
Load Range	H	L	L	Front:J Rear:L
Inflation Pressure (Maximum Load):				
Front	105 psi (724 kPa)	115 psi (793 kPa)	115 psi (793 kPa)	90 psi (621 kPa)
Rear	100 psi (690 kPa)	90 psi (621 kPa)	90 psi (621 kPa)	90 psi (621 kPa)
Spare	105 psi (724 kPa)	115 psi (793 kPa)	115 psi (793 kPa)	90 psi (621 kPa)
<b>Steering:</b>				
Manufacturer	Ross	Ross	Ross	Ross
Steering Gear Type	Single gear	Single gear	Single gear	Single gear

**1-12. EQUIPMENT DATA (Con't).**

**Table 1-1. Equipment Data (Con't).**

Data	Model			
	M915A2	M916A1	M916A2	M917A1/ M917A1 w/MCS
<b>Steering (Con't):</b>				
Actuation	hydraulic power booster	hydraulic power booster	hydraulic power booster	hydraulic power booster
Power Steering Pump	Eaton B165R	Eaton B165R	Eaton B165R	Eaton B165R
Turning Diameter	53 ft 9 in. (76.4 m)	80 ft (24.4 m)	80 ft (24.4 m)	38.9 ft (11.9 m)
<b>Towing Attachments:</b>				
Pintle Hook:				
Manufacturer	Holland	Holland	Holland	Holland
Model	No. 760	No. 760	No. 760	No. 760
Rated Capacity	30 tons (27.2 metric tons)	30 tons (27.2 metric tons)	30 tons (27.2 metric tons)	30 tons (27.2 metric tons)
Towing Eyes:				
Quantity	2 front, 2 rear	2 front, 2 rear	2 front, 2 rear	2 front, 2 rear
Maximum Load Capacity, Each (Up to 45° Angle Front Long. Axis)	60,000 lb (27,240 kg)	60,000 lb (27,240 kg)	60,000 lb (27,240 kg)	60,000 lb (27,240 kg)
Fifth Wheel:				
Manufacturer	Holland	Holland	Holland	N/A
Type	36 in. (91.4 cm) diameter, 2-way oscillating	36 in. (91.4 cm) diameter, 4-way oscillating	36 in. (91.4 cm) diameter, 4-way oscillating	N/A
Pitch (Fwd/Aft)	15/10°	15/10°	15/10°	N/A



**1-12. EQUIPMENT DATA (Con't).**

**Table 1-1. Equipment Data (Con't).**

Data	Model			
	M915A2	M916A1	M916A2	M917A1/ M917A1 w/MCS
<b>Towing Attachments (Con't):</b> Kingpin Size	2 in. (5.1 cm)	3.5 in. (8.9 cm)	3.5 in. (8.9 cm)	N/A
<b>Hydraulic Winch:</b> Manufacturer	N/A	D.P. Winch	D.P. Winch	N/A
Model	N/A	DP45BD	DP45BD	N/A
Rated Capacity	N/A	45,000 lb (20,430 kg)	45,000 lb (20,430 kg)	N/A
Drum Capacity	N/A	150 ft (45.7 m) of cable	150 ft (45.7 m) of cable	N/A
Cable Diameter	N/A	7.8 in. (2.2 cm)	7.8 in. (2.2 cm)	N/A
Speed:				
High	N/A	26 ft (7.9 m) per minute	26 ft (7.9 m) per minute	N/A
Low	N/A	13 ft. (3.96 m) per minute	13 ft (3.96 m) per minute	N/A
<b>Cab:</b> Manufacturer	Freightliner	Freightliner	Freightliner	Freightliner
Construction	Aluminum	Aluminum	Aluminum	Aluminum
Type	2-passenger, tilt-forward hood	2-passenger, tilt-forward hood	2-passenger, tilt-forward hood	2-passenger, tilt-forward hood
<b>Accessories:</b> Utility Lights	2 fixed	2 fixed	2 fixed	N/A
Air Horn	1, top of cab	1, top of cab	1, top of cab	1, under cab

**1-12. EQUIPMENT DATA (Con't).**

**Table 1-1. Equipment Data (Con't).**

Data	Model			
	M915A2	M916A1	M916A2	M917A1/ M917A1 w/MCS
<b>Military Load Classification:</b> Vehicle w/o Trailer	8	12	12	(unloaded/ loaded)
Vehicle w/Trailer:				
M871	14/35 (unloaded/ loaded)	N/A	N/A	N/A
M872	14/46 (unloaded/ loaded)	N/A	N/A	N/A
M1062	11/34 (unloaded/ loaded)	N/A	N/A	N/A
M172	N/A	16/38 (unloaded/ loaded)	16/38 (unloaded/ loaded)	N/A
M870	N/A	17/54 (unloaded/ loaded)	17/54 (unloaded/ loaded)	N/A
60PRS	N/A	23 (unloaded/ loaded)	23 (unloaded/ loaded)	N/A
WD6S	N/A	23 (unloaded/ loaded)	23 (unloaded/ loaded)	N/A

### Section III. PRINCIPLES OF OPERATION

Paragraph Number	Paragraph Title	Page Number
1-13.	Introduction .....	1-25
1-14.	Drive Train.. .....	1-26
1-15.	Fuel System .....	1-27
1-16.	Exhaust System .....	1-28
1-17.	Cooling System .....	1-28
1-18.	Electrical System .....	1-29
1-19.	Air System.. .....	1-30
1-20.	Brakes .....	1-30
1-21.	Steering .....	1-32
1-22.	Hydraulic System (All Except M915A2) .....	1-32
1-23.	Air Conditioning System (All Except M915A2 and M916A1) .	1-34
1-24.	Central Tire Inflation System (CTIS) (M917A1 and M917A1 w/MCS) .....	1-34

#### 1-13. INTRODUCTION.

- a. All vehicles consist of eight functional systems: drive train, fuel system, exhaust system, cooling system, electrical system, air system, brakes, and steering.
- b. All vehicles except the M915A2 have a hydraulic system.
- c. All vehicles except the M915A2 and M916A1 have an air conditioning system.
- d. An additional system on the M917A1 and M917A1 w/MCS is the Central Tire Inflation System (CTIS).
- e. This section explains the overall operation of these systems.

---

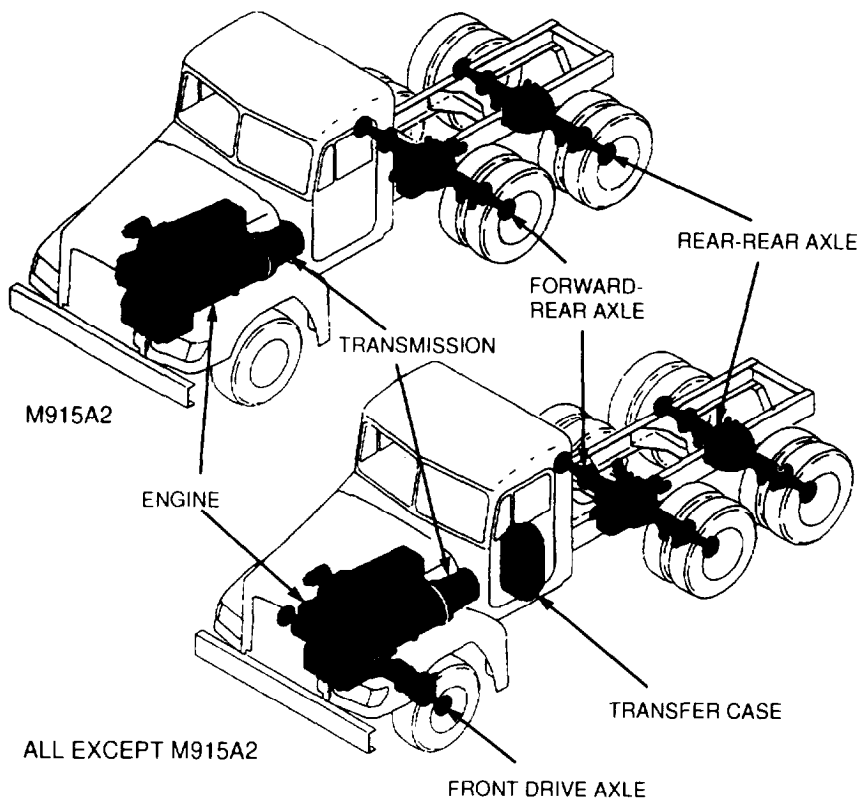
**1-14. DRIVE TRAIN.**

---

a. The drive train of the M915A2 consists of a 60 Series Detroit Diesel engine and an Allison 4-speed automatic transmission connected to RT 40-145P rear tandem axles.

b. The M916A1 and M916A2 have RT52-160P rear tandem axles and an Oshkosh front drive axle. The axles receive power through an Oshkosh transfer case from the transmission and engine.

c. The M917A1 and M917A1 w/MCS drive train is similar to the M916A2. It differs in that all axles are modified to incorporate CTIS plumbing.



---

**1-15. FUEL SYSTEM.**


---

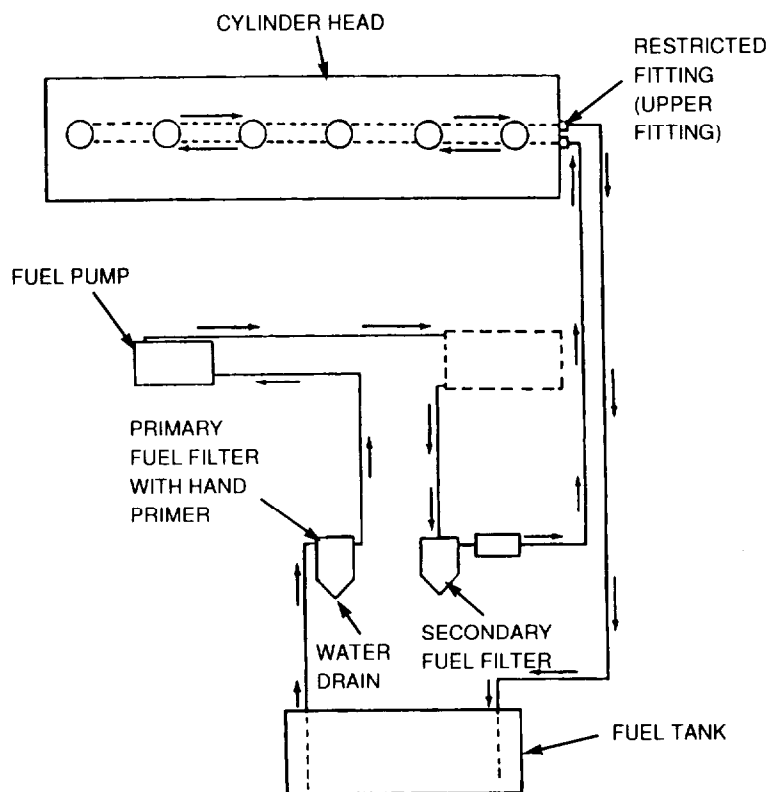
a. Fuel to power the engine is pumped out of the fuel tank by an engine-mounted fuel pump. The engine fuel system consists of one electronic unit injector per cylinder, a transfer pump, low-pressure fuel lines, and primary and secondary filters.

b. The engine is governed by an electronic control system. The system controls idle speed and limits engine maximum speed. The driver controls engine speed through the position of the electric foot pedal assembly.

c. Fuel filters are spin-on types. The primary fuel filter has a hand fuel primer pump and a water drain.

d. Fuel may be drained from the tank through the drain port located on the bottom of the tank.

e. There is an ether quick-start system for use in cold weather. On the M915A2, M916A1, and initially-built M916A2, M917A1, and M917A1 w/MCS it is manually controlled via a push button on the instrument panel in the cab. On newer M916A2, M917A1, and M917A1 w/MCS models, the ether quick-start system is computer controlled.

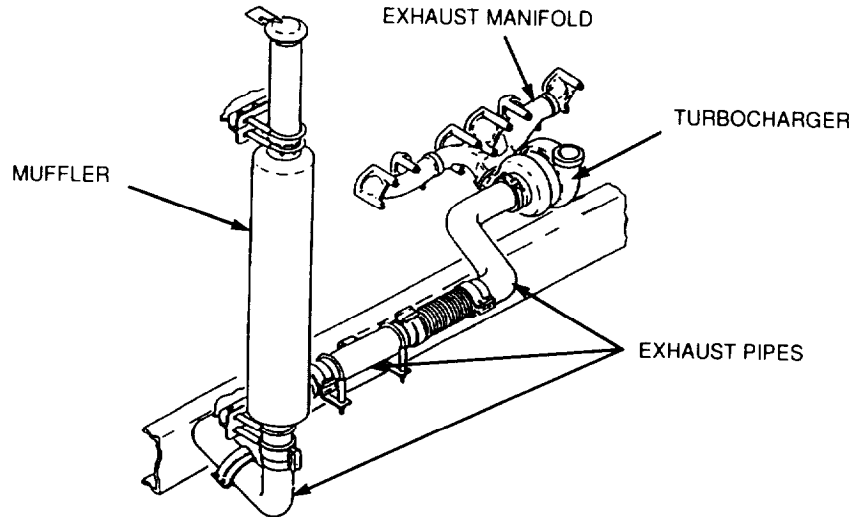


---

## 1-16. EXHAUST SYSTEM.

---

The exhaust system removes exhaust gases from the engine through the exhaust manifold and turbocharger. The gases flow into exhaust pipes and a muffler to the atmosphere above the cab.



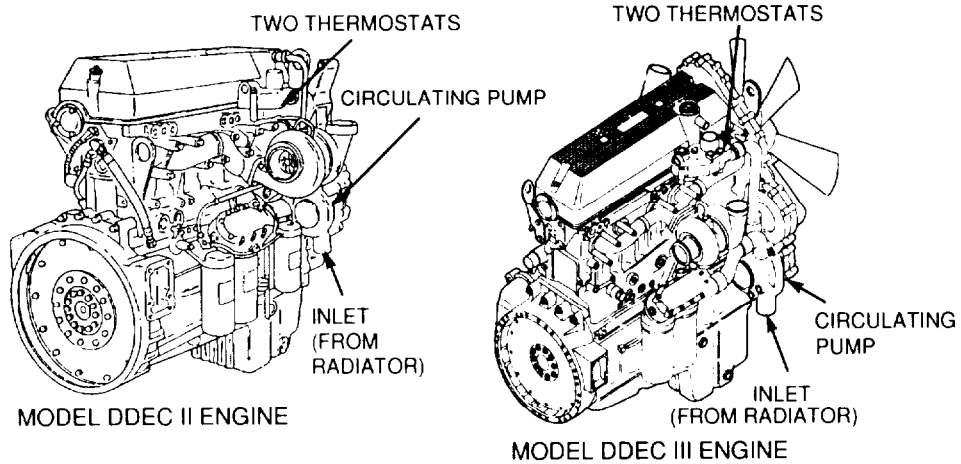
---

## 1-17. COOLING SYSTEM.

---

The cooling system consists of one circulating pump, a coolant filter, two 190°F thermostats for controlling fluid flow, a transmission oil cooler, a radiator, and a belt-driven fan. The cooling system cools the engine by means of circulating pressurized ethylene-glycol based coolant through the engine and radiator.

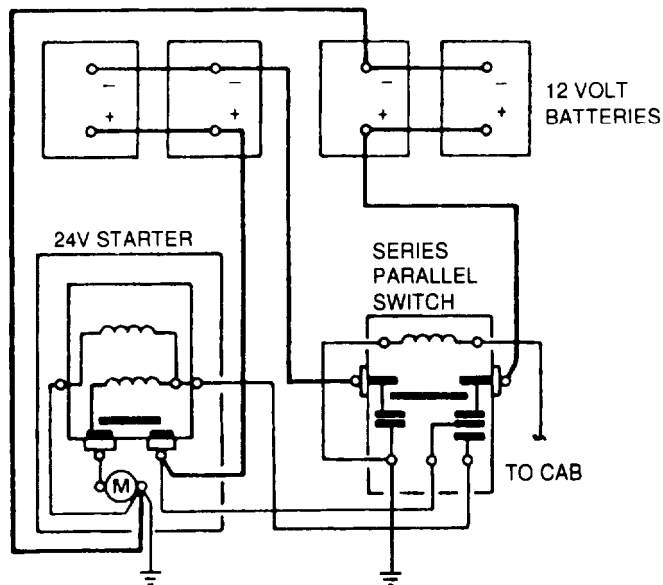
**1-17. COOLING SYSTEM (Con't).**



**1-18. ELECTRICAL SYSTEM.**

a. Four 12-volt batteries connected in series-parallel supply the 12-volt electrical system and provide 24 volts for the starter motor, blackout lights, accessories, and trailer connectors.

b. The Dual Voltage Alternator Control (DUVAC), mounted on the fire-wall in the engine compartment, regulates the distribution of 12 and 24 volts.



---

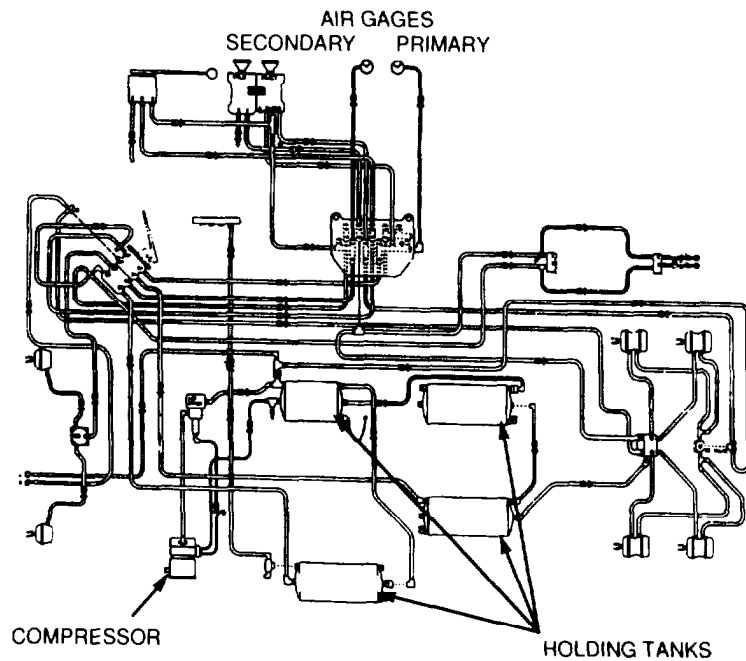
## 1-19. AIR SYSTEM.

---

a. The air system consists of the air compressor, air dryer, air reservoirs, and various air lines. Also included in the air system are the air pressure gages located on the dashboard which are used for monitoring air pressure for safe operation of all air-operated components of the vehicle.

b. On the M917A1 and M917A1 w/MCS, the chassis air system supplies air to operate the Central Tire Inflation System (CTIS) and the tailgate release air cylinder (TM 5-3805-264-14&P).

On the M917A1 w/MCS, the chassis air system interfaces with the MCS air system to operate the MCS tailgate (TM 5-3805-264-14&P).




---

## 1-20. BRAKES.

---

a. The dual air brake system consists of two independent air brake systems that use a single set of brake controls. Each system has its own reservoirs, plumbing, and brake chambers. The primary system operates the service brakes on the rear axle; the secondary system operates the service brakes on the front axle. On tractor-trailer configurations, service brake signals from both systems are sent to the trailer.



**1-20. BRAKES (Con't).**

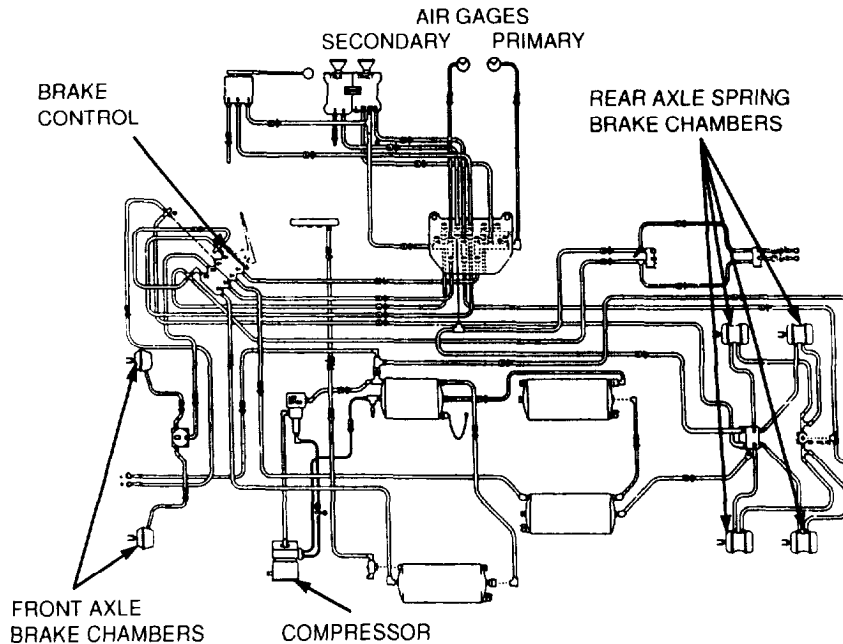
b. Loss of air pressure in the primary system causes the rear service brakes to become inoperative; front brakes will continue to be operated by secondary system air pressure. In addition, trailer brakes will be operated by the secondary system. Loss of secondary system air pressure causes the front axle brakes to become inoperative; rear service brakes and trailer brakes will be operated by the primary system.

c. The warning light and buzzer inside the cab come on if air pressure drops below 64 psi (441 kPa) in either system. If this happens, check the air pressure gages to determine which system has low air pressure. Although the vehicle's speed can be reduced using the foot brake control pedal, either the front or rear service brakes will not be operating, causing a longer stopping distance. Bring the vehicle to a safe stop and have the air system repaired before continuing.

d. On tractor-trailer vehicles, if both the primary and secondary systems become inoperative, the trailer service brakes or spring parking brakes will automatically apply when air pressure drops to 35-45 psi (241-310 kPa). The tractor spring parking brakes will automatically apply when air pressure drops below 45 psi (310 kPa).

e. All vehicles have a four-channel anti-lock brake system (ABS) and cam-operated service brakes with non-asbestos brakeshoes.

f. All vehicles except M915A2 and M916A1 have automatically adjusting slack adjusters. On all axles, brake chambers have a stroke alert indicator which allows the operator to monitor brakeshoe wear.



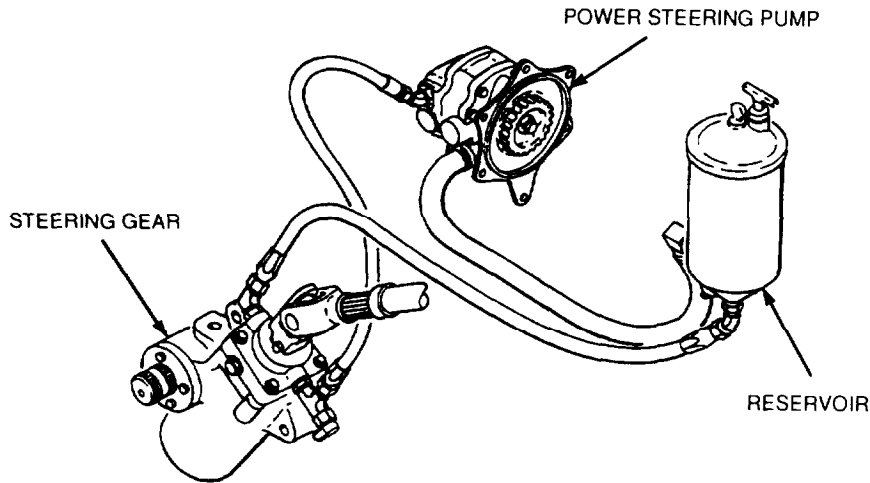
---

## 1-21. STEERING.

---

The power steering system consists of an integral steering gear (which includes a manual steering mechanism and hydraulic control valve), hydraulic hoses, power steering pump, reservoir, and other components.

b. The power steering pump, driven by the engine, provides the power-assist for the steering system.



---

## 1-22. HYDRAULIC SYSTEM (ALL EXCEPT M915A2).

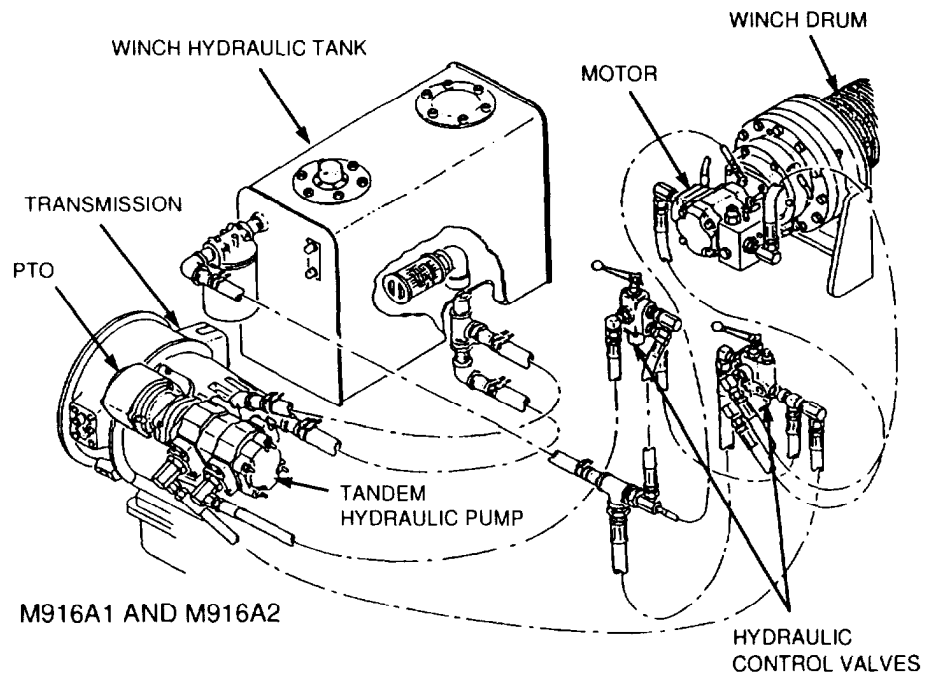
---

a. The M916A1 and M916A2 have a hydraulic system that is used to supply hydraulic power to the winch motor. The hydraulic system is comprised of a 50-gallon frame-mounted tank and a hydraulic pump driven by a transmission-mounted PTO.

b. On the M916A1 and M916A2, with the engine running and the PTO engaged, the hydraulic pump takes fluid from the tank and delivers it to the winch control valve bank. The valve bank consists of a two-speed control valve and a direction control valve.

The M917A1 and M917A1 w/MCS hydraulic system is used to raise and lower the dump body (TM 5-3805-264-14&P).

1-22. HYDRAULIC SYSTEM (ALL EXCEPT M915A2) (Con't).

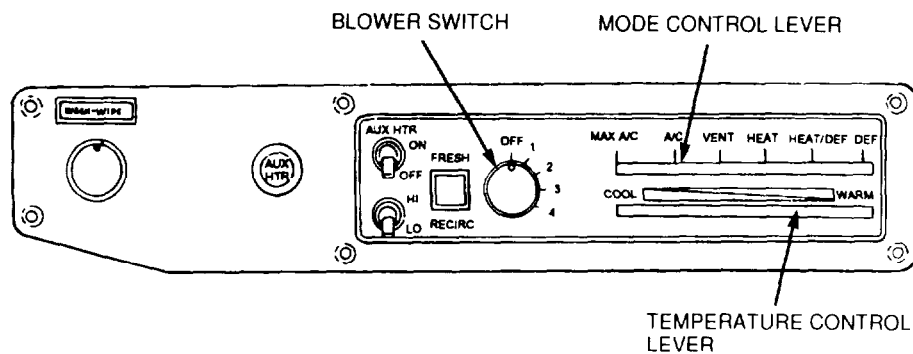


---

**1-23. AIR CONDITIONING SYSTEM (ALL EXCEPT M915A2 AND M916A1).**

---

- a. The air conditioning unit is part of the heater and is mounted under the glove compartment. It is a single unit consisting of heater core, air conditioning evaporator coil, blower motor, control valves, and air ducts.
- b. The system is turned on by the mode control lever and the four-speed blower switch, which also controls flow rate.
- c. An even cab temperature is maintained by controlling the coolant flow through the heater core, or refrigerant flow through the evaporator coil.



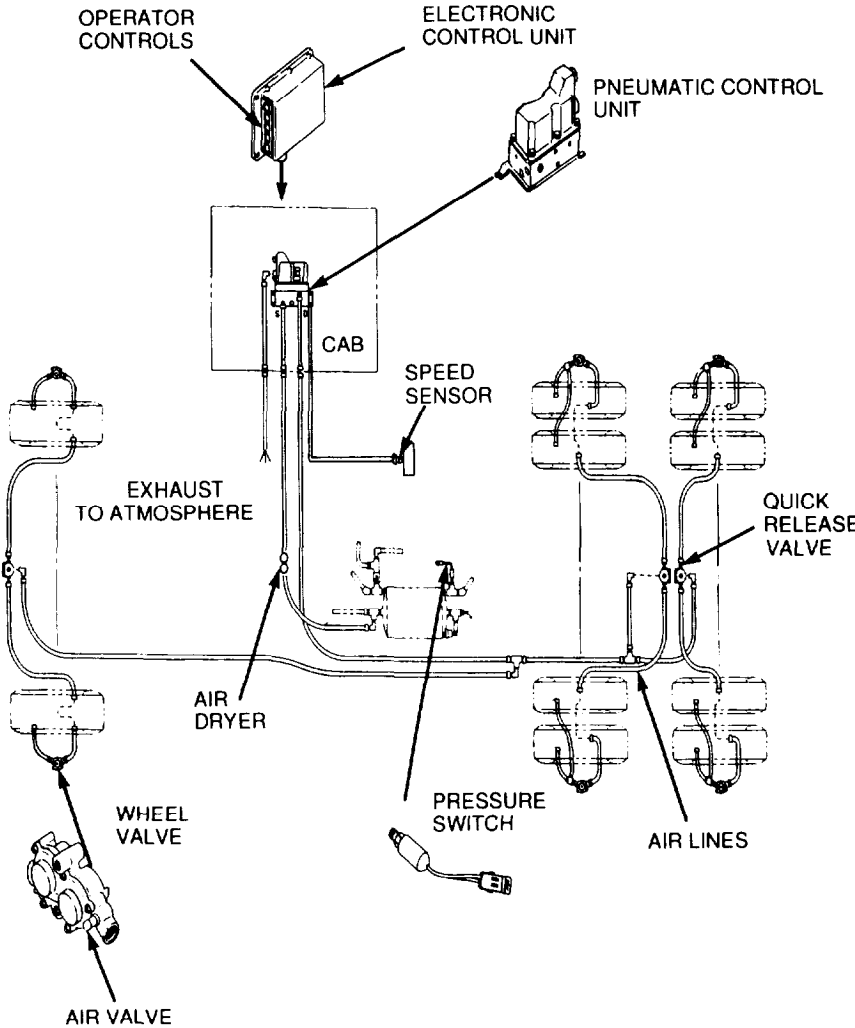

---

**1-24. CENTRAL TIRE INFLATION SYSTEM (CTIS) (M917A1 AND M917A1 W/MCS).**

---

- a. The operator uses CTIS to regulate tire pressure at all wheels. This allows operation of the dump truck on all road surfaces and across a wide variety of terrain, including off-road, when the vehicle is stuck due to extreme conditions (ice, snow, mud), and when a tire has a slow leak due to a minor puncture or other damage.
- b. CTIS uses air from the vehicle air system (paragraph 1-19). Air is routed to the wheels via a dedicated pneumatic system plumbed from the vehicle's wet tank.
- c. An Electronic Control Unit (ECU) is mounted to the shift tower inside the cab. An operator selector panel is built into the ECU, allowing operator entry of system commands/instructions.

1-24. CENTRAL TIRE INFLATION SYSTEM (CTIS) (M917A1 AND M917A1 W/MCS) (Con't).



**1-24. CENTRAL TIRE INFLATION SYSTEM (CTIS) (M917A1 AND M917A1 W/MCS) (Con't).**

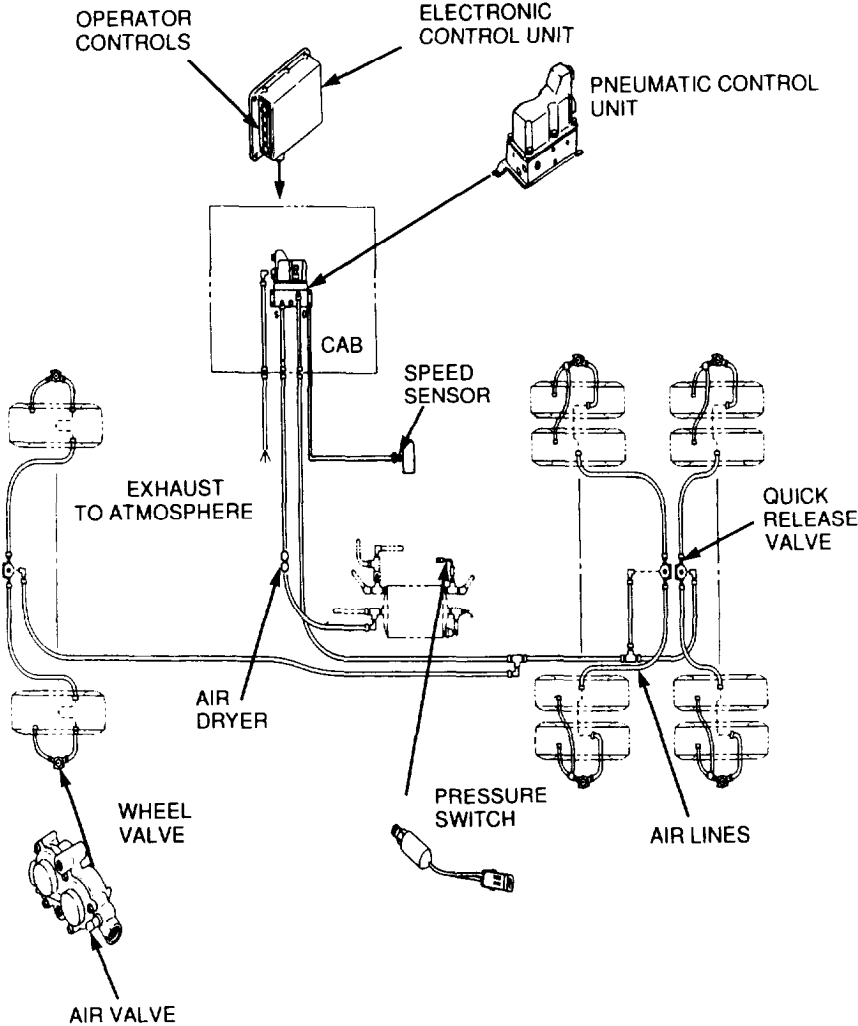
d. Four terrain settings may be selected: HIGHWAY (HWY); CROSS-COUNTRY (X-C); SAND; EMERGENCY (EMER); and the RUN FLAT mode. If tire damage is minimal (e.g., a minor puncture or slow leak), selecting RUN FLAT causes CTIS to monitor tire pressure every fifteen seconds and re-inflate the tire.

e. Tire pressure can be manually checked and air added to tires through a conventional air valve located at each wheel valve.

f. Major components of the CTIS are:

COMPONENT	FUNCTION
Electronic Control Unit (ECU)/Operator Selector Panel	Contains microprocessor that controls the system and operator selector panel.
Pneumatic Control Unit	Directs air pressure through air lines to the wheel valves, according to ECU commands.
Air Dryer	Separates moisture and filters impurities from compressed air system before air enters the CTIS.
Pressure Switch	Acts as a brake priority switch by preventing CTIS from consuming air until the air brake system has a minimum of 85 psi (586 kPa) of air.
Speed Sensor	Mounted at transfer case. Senses vehicle speed and signals the ECU to automatically inflate tires when vehicle speed exceeds by 10 mph (16 kph) the top speed setting for the selected mode.
Quick Release Valves	Allow air from PCU to inflate or vent air during deflation.
Wheel Valves	Isolate air pressure in tire during normal operation and for tire removal. Air valve on wheel valve allows for inflation and deflation using standard manual inflation equipment.

1-24. CENTRAL TIRE INFLATION SYSTEM (CTIS) (M917A1 AND M917A1 W/MCS) (Con't).







## CHAPTER 2 OPERATING INSTRUCTIONS

---

### Section I. DESCRIPTION AND USE OF OPERATOR'S CONTROLS AND INDICATORS

Paragraph Number	Paragraph Title	Page Number
2-1.	General .....	2-1
2-2.	Instrument Panel .....	2-2
2-3.	Steering Wheel and Column-Mounted Controls .....	2-20
2-4.	Cab Floor-Mounted Controls .....	2-21
2-5.	Seat Controls, .....	2-24
2-6.	CTIS Controls and Indicators (M917A1 and M917A1 w/MCS)	2-26
2-7.	Winch Controls (M916A1 and M916A2) .....	2-29
2-8.	Additional Controls and Indicators. ....	2-30

---

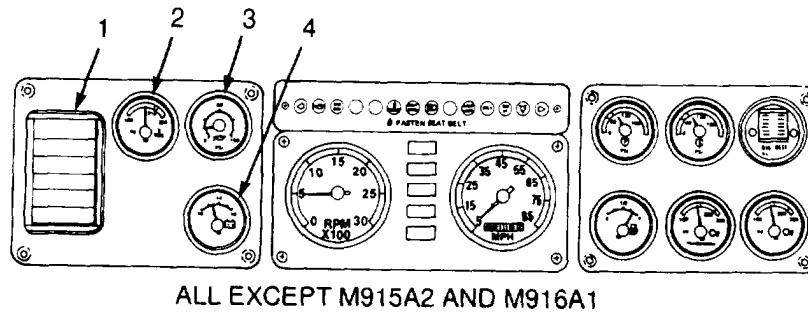
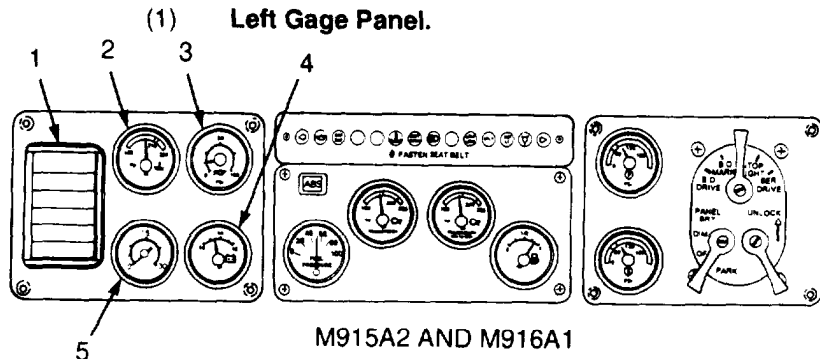
#### 2-1. GENERAL.

---

Do not attempt to operate the M915 Family of Vehicles until becoming familiar with the location and use of all controls and indicators. The following section describes all operator controls and indicators.

**2-2. INSTRUMENT PANEL.**

**a. Instrument Cluster.**

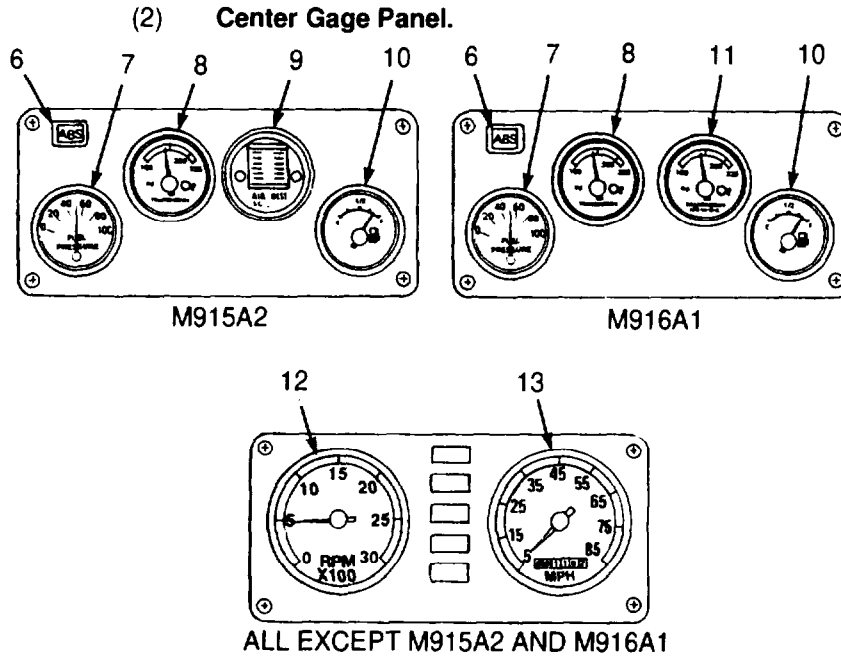


Key	Control or Indicator	Function
1	Air Vent	Vents air into cab from heater/ventilator/defroster and air conditioner, if equipped. Louvered openings are adjustable.
2	Engine Water Temperature Gage	Registers engine coolant temperature in degrees Fahrenheit. Normal range is in green band, 190-210°F (88-99°C). If needle goes into yellow band, 210-215°F (99-120°C) or red band, 216-250°F (102-121°C), stop and investigate cause.
3	Engine Oil Pressure Gage	Registers engine oil pressure in psi (kPa). Normal pressure at rated speed (1200 rpm) is 50 psi (345 kPa). Pressure at idle speed (600 rpm) is 12 psi (83 kPa) minimum.

**2-2. INSTRUMENT PANEL (Con't).**

Key	Control or Indicator	Function
4	Voltmeter	<p>Indicates rate of battery charge or discharge in volts.</p> <ul style="list-style-type: none"> <li>(a) RED BAND. Below 11 volts indicates a possible malfunction. Stop and report problem to Unit Maintenance.</li> <li>(b) YELLOW BAND. 11-12 volts indicates battery is undercharged. Turn off all electrical circuits, if possible, and run engine at highest rpm permitted for existing conditions. If reading is still not in green band, notify Unit Maintenance.</li> <li>(c) GREEN BAND. 13-15 volts indicates normal operating range.</li> <li>(d) RED BAND. Above 15volts indicates batteries are being overcharged. Notify Unit Maintenance.</li> </ul>
5	Turbo Boost Gage (M915A2 and M916A1)	<p>Measures pressure in intake manifold, in excess of atmospheric pressure, being created by turbocharger. Normal pressure is 28 psi (193 kPa) at full load.</p>

2-2. INSTRUMENT PANEL (Con't).



Key	Control or Indicator	Function
6	ABS Warning Light (M915A2 and M916A1)	Lights when ignition switch is turned on. If ABS components are working, light goes out when vehicle speed exceeds 4 mph (6 kph). Light blinks when vehicle is in interaxle lockout/all-wheel drive.
7	Fuel Pressure Gage (M915A2 and M916A1)	Indicates output fuel pressure of fuel pump. Normal range is 35-65 psi (241-448 kPa).
8	Transmission Oil Temperature Gage (M915A2 and M916A1)	Indicates oil temperature in transmission. Normal range in green band is 100-299°F (38-148°C). If needle goes into yellow band, 300-324°F (149-162°C), or red band, 325°F (163°C) or above, stop and investigate cause.

---

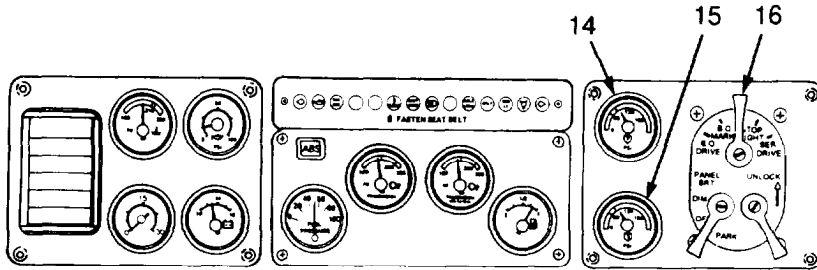
**2-2. INSTRUMENT PANEL (Con't).**


---

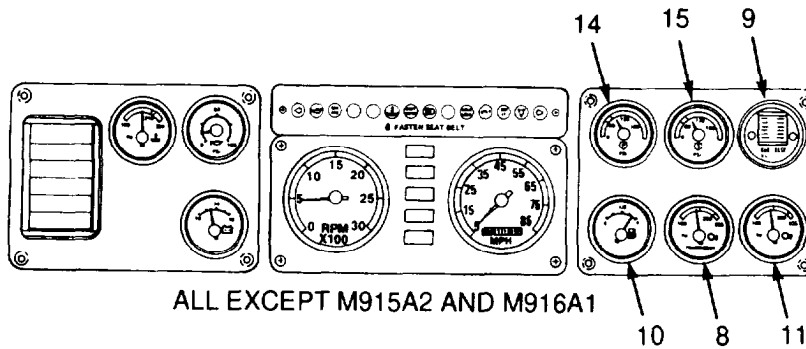
Key	Control or Indicator	Function
9	Air Cleaner Restriction Indicator Gage (M915A2)	Indicates air cleaner air flow is adequate if gage is clear. If restricted, indicator window will show yellow. Push yellow reset button to reset after air cleaner has been serviced.
10	Fuel Gage (M915A2 and M916A1)	Indicates amount of fuel in fuel tank when ignition switch is turned on.
11	Transfer Case Oil Temperature Gage (M916A1)	Indicates oil temperature in transfer case. (a) GREEN BAND. Range of 100-275°F (38-135°C) is normal. (b) YELLOW BAND. Range of 275-300°F (135-149%) indicates oil temperature is too high and gage must be closely monitored. (c) RED BAND. Above 300°F (149°C). Disengage all- wheel drive and perform troubleshooting.
12	Tachometer (All Except M915A2 and M916A1)	Registers engine speed in rpm. Maximum governed speed is 2100 rpm. Idle speed is 600 rpm.
13	Speedometer/ Odometer (All Except M915A2 and M916A1)	Registers vehicle ground speed in mph/kph (speedometer) and distance traveled (seven-digit odometer) in miles.

2-2. INSTRUMENT PANEL (Con't).

(3) Right Gage Panel.



M915A2 AND M916A1



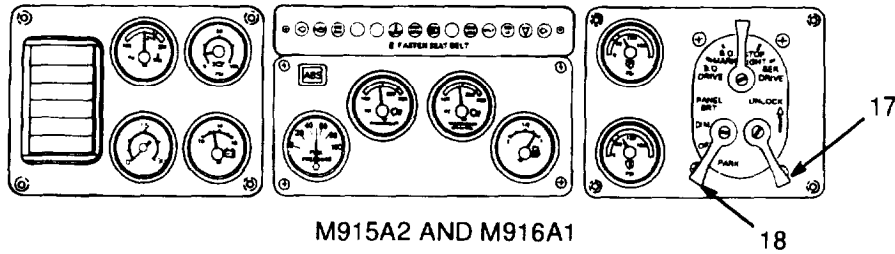
ALL EXCEPT M915A2 AND M916A1

Key	Control or Indicator	Function
8	Transmission Oil Temperature Gage (All Except M915A2 and M916A1)	Indicates oil temperature in transmission. Normal range in green band is 100-299°F (38-148°C). If needle goes into yellow band, 300-324°F (149-162°C), or red band, 325°F (163°C) or above, stop and investigate cause.
9	Air Cleaner Restriction Indicator Gage (All Except M915A2 and M916A1)	Indicates air cleaner air flow is adequate if gage is clear. If restricted, indicator window will show up to 20 inches of water. Push yellow reset button to reset after air cleaner has been serviced.
10	Fuel Gage (All Except M915A2 and M916A1)	Indicates amount of fuel in fuel tank when ignition switch is turned on.

**2-2. INSTRUMENT PANEL (Con't).**

Key	Control or Indicator	Function
11	Transfer Case Oil Temperature Gage (All Except M915A2 and M916A1)	<p>Indicates oil temperature in transfer case.</p> <p>(a) GREEN BAND. Range of 100-275°F (38-135°C) is normal.</p> <p>(b) YELLOW BAND. Range of 275-300°F (135-149°C) indicates oil temperature is too high and gage must be closely monitored.</p> <p>(c) RED BAND. Above 300°F (149°C). Disengage all-wheel drive and perform troubleshooting.</p>
14	Primary Air Pressure Gage	<p>Registers air pressure (in psi) in rear brake system. Normal operating range is 90-120 psi (621-827 kPa).</p>
15	Secondary Air Pressure Gage	<p>Registers air pressure (in psi) in front brake system. Normal operating range is 90-120 psi (621-827 kPa).</p>
16	Main Light Switch (M915A2 and M916A1)	<p>Five-position switch. To engage, mechanical switch must be held in UNLOCK position (up). Switch positions are:</p> <p>(a) BO DRIVE. Same as BO MARKER position, but blackout drive light and trailer circuit will also function.</p> <p>(b) BO MARKER. Blackout marker/tail lights and blackout stop lights will function. No other lights or electrical horn will function.</p> <p>(c) OFF. No lights or electrical horn will function.</p> <p>(d) STOP LIGHT. Electrical horn and all separately controlled lights will function except blackout stop lights. No marker/tail lights or drive/headlights will function.</p> <p>(e) SER DRIVE. Same as STOP LIGHT position, but headlight and "non-blackout" marker/tail lights will function.</p>

2-2. INSTRUMENT PANEL (Con't).



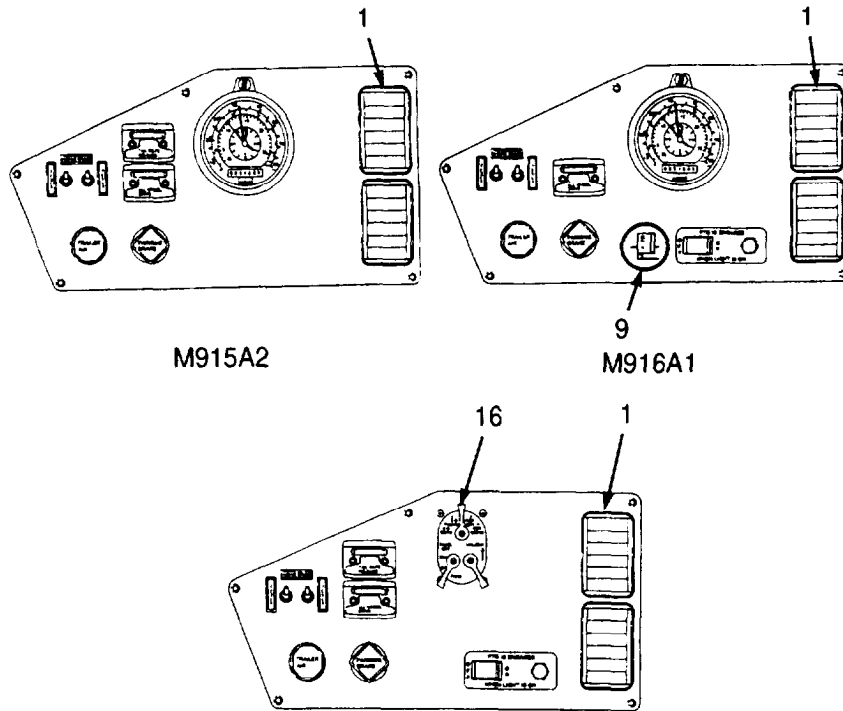
M915A2 AND M916A1

Key	Control or Indicator	Function
17	Mechanical Switch (M915A2 and M916A1)	Spring-loaded, two-position switch. Switch positions are: (a) LOCK. Down position prevents movement of main light switch. (b) UNLOCK position. Up position enables movement of main light switch. Hold lever in UNLOCK position and move main light switch to desired position.
18	Auxiliary Switch (M915A2 and M916A1)	Four-position switch. Will not function if main light switch is OFF. Switch positions are: (a) PANEL BRT. Bright panel lights will function except if main light switch is in OFF, BO DRIVE, or BO MARKER positions. (b) PANEL DIM. Same as PANEL BRT position, but panel lights dimmer switch may dim lights. (c) PANEL OFF. Panel lights will not function. (d) PARK. When main light switch is in SER DRIVE position, headlights will be deactivated, leaving all service marker/tail lights functioning.



2-2. INSTRUMENT PANEL (Con't).

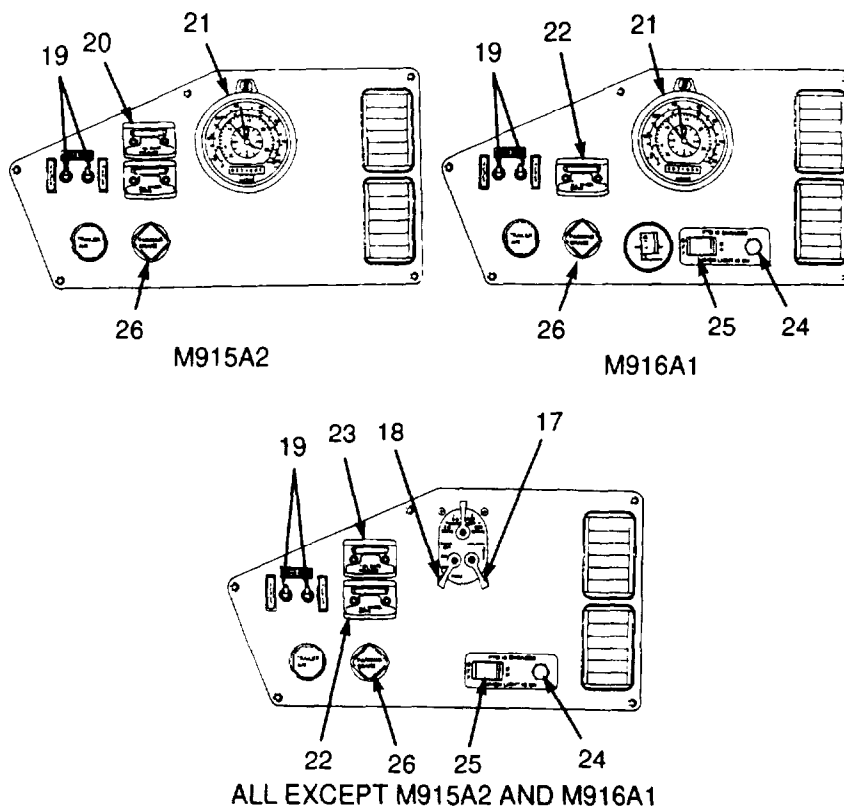
b. Upper Right Dash Panel.



ALL EXCEPT M915A2 AND M916A1

Key	Control or Indicator	Function
1	Air Vents	Vent air into cab from heater/ventilator/defroster and air conditioner, if equipped. Louvered openings are adjustable.
9	Air Cleaner Restriction Indicator Gage (M916A1)	Indicates air cleaner air flow is adequate if gage is clear. If restricted, indicator window will show up to 20 inches of water. Push yellow reset button to reset after air cleaner has been serviced.
16	Main Light Switch (All Except M915A2 and M916A1)	Five-position switch. Operates the same as main light switch on other model trucks. Refer to item 16 in subparagraph a(3).

2-2. INSTRUMENT PANEL (Con't).

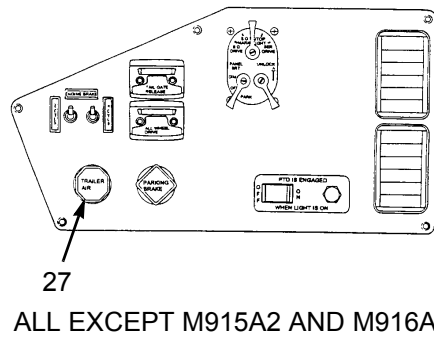
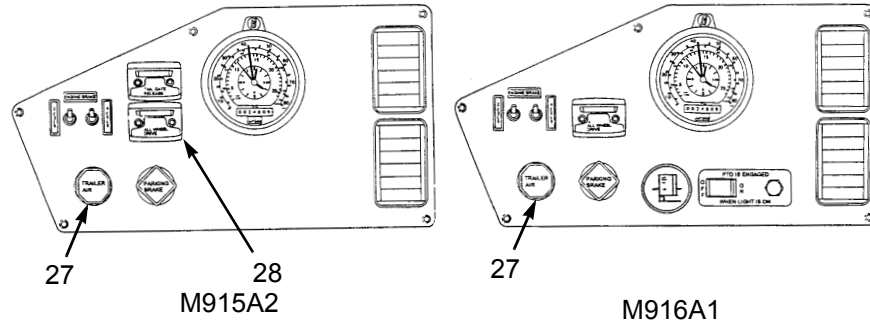


Key	Control or Indicator	Function
17	Mechanical Switch (All Except M915A2 and M916A1)	Spring-loaded, two-position switch. Operates the same as mechanical switch on other model trucks. Refer to item 17 in subparagraph a(3).
18	Auxiliary Switch (All Except M915A2 and M916A1)	Four-position switch. Operates the same as auxiliary switch on other model trucks. Refer to item 18 in subparagraph a(3).
19	Engine (Jake) Brake Selection Switches	Selects number of engine cylinders desired for braking action (two, four, or six cylinders). Turn on left switch for two cylinders, right switch for four cylinders, and both switches for all six cylinders.

**2-2. INSTRUMENT PANEL (Con't).**

Key	Control or Indicator	Function
20	Fifth Wheel Slide (M915A2)	Permits repositioning of sliding fifth wheel from inside cab. LOCK position deactivates control valve and locks fifth wheel to baseplate. UNLOCK position activates control valve to allow changes to total length of tractor-trailer and changes to axle loads.
21	Tachograph (M915A2 and M916A1)	Registers truck ground speed (mph/kph hand), engine speed (rpm hand), and distance traveled (odometer). Other two hands are clock hands. With a tachograph disk installed, data is recorded on a seven-day graph for a permanent record.
22	All-Wheel Drive Control Valve Lever (All Except M915A2)	Engages and disengages front driving axle based on changing driving conditions. (a) ENGAGE. In poor traction conditions, stop vehicle and move lever to left position to lock up driveline and engage front driving axle. (b) DISENGAGE. When conditions are back to normal, move lever to right position and let up on accelerator to disengage.
23	Tailgate Release Control Valve Lever (M917A1 and M917A1 w/MCS)	Unlocks and locks dump body tailgate (TM 5-3805-264-14&P).
24	PTO Indicator Light (All Except M915A2)	Indicates when PTO is turned on.
25	PTO Switch (All Except M915A2)	Positions are ON and OFF. Engages PTO. PTO will not operate unless main light switch is in SER DRIVE or STOP LIGHT position (M917A1 and M917A1 w/MCS).
26	Parking Brake Control	Yellow diamond-shaped knob operates parking brake valve. Pull out to apply and push in to release parking brake.

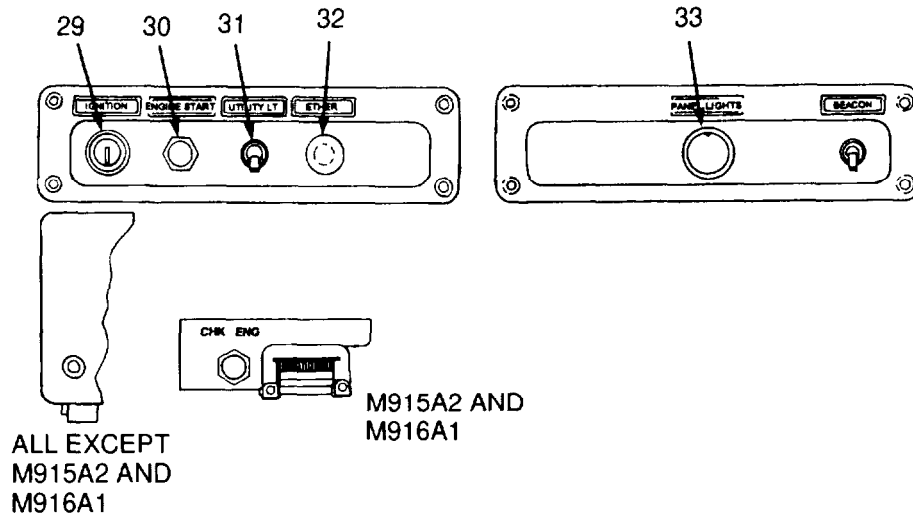
**2-2. INSTRUMENT PANEL (Con't).**



Key	Control or Indicator	Function
27	Trailer Air Supply Control	Red octagonal-shaped knob supplies air to trailer air reservoirs. Push in to charge trailer air supply and release trailer spring brakes. Pull out to shut off air supply.
28	Interaxle Lockout Control Valve Lever (M915A2)	Locks and unlocks driveline based on changing driving conditions. (a) LOCK. In poor traction conditions, stop vehicle and place lever in LOCK position to lock up driveline. (b) UNLOCK. When conditions are back to normal, move left to UNLOCK while vehicle is moving.

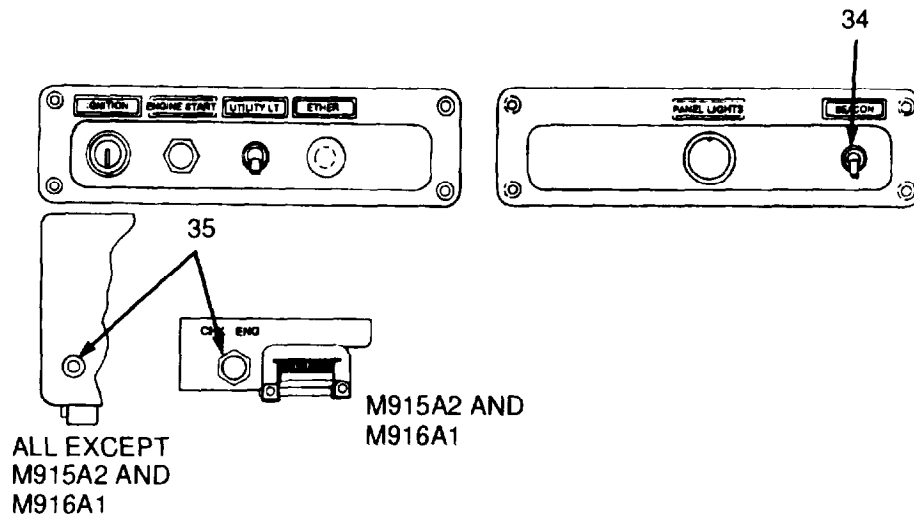
2-2. INSTRUMENT PANEL (Con't).

c. Lower Control Panel.



Key	Control or Indicator	Function
29	Ignition Switch	Operates gages/switches/sending units, instrument panel lights, and engine start. Turn key in switch to right for ON position. Turn key fully counterclockwise to activate accessories. Turn key to center vertical position to turn all systems OFF.
30	Engine Start Button	Press to energize starter solenoid. Release button as soon as engine starts.
31	Utility Light Switch (All Except M917A1 and M917A1 w/MCS)	ON/OFF toggle switch controls utility lights mounted on back of cab. Up position is ON. Down is OFF.
32	Ether Quick-Start Button	Press and release button to manually inject ether for starting in cold weather. Button is removed on vehicles with automatic ether injection systems.
33	Panel Lights Control Knob	Brightens or dims instrument panel lights. Turn clockwise to brighten and counterclockwise to dim. Turn fully counterclockwise to shut off panel lights.

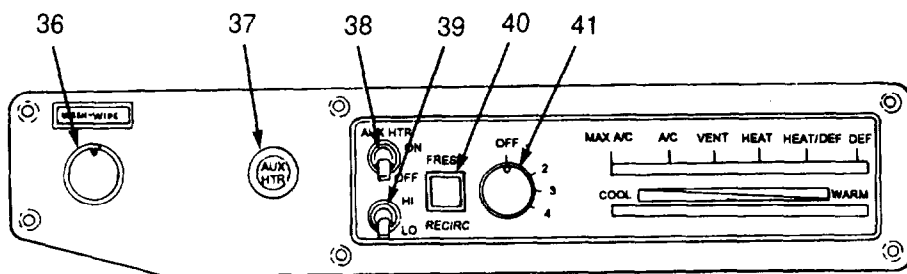
2-2. INSTRUMENT PANEL (Con't).



Key	Control or Indicator	Function
34	Beacon Light Switch	ON/OFF toggle switch controls beacon warning light on top of vehicle.
35	Check Engine (CHK ENG) Button	Used by maintenance personnel for engine diagnostic purposes ONLY.

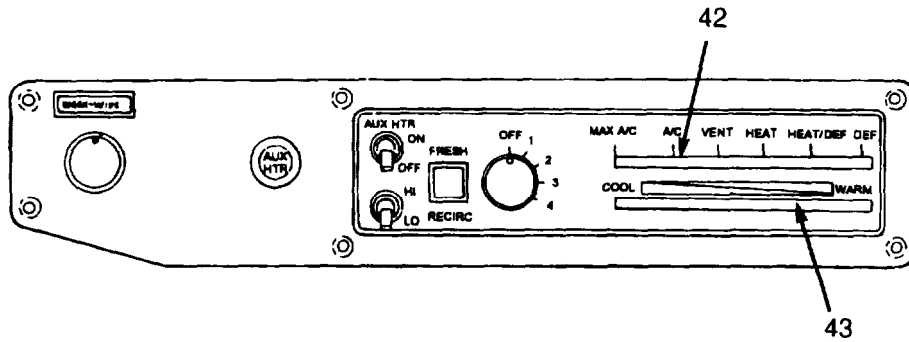
2-2. INSTRUMENT PANEL (Con't).

d. Lower Right Dash Panel



Key	Control or Indicator	Function
36	Wiper/Washer Control	Turns windshield wipers on/off. Clockwise is ON. Counterclockwise is OFF. To wash windshield, press knob in to spray water and to turn wipers on.
37	Auxiliary Heater Indicator Light	Lights up when heater burner is lit.
38	Auxiliary Heater Control Switch	Operates arctic personnel heater. Positions are ON and OFF.
39	HI-LO Switch	Controls rate of heating for arctic personnel heater. If set at HI, heater burner will go on when coolant temperature at inlet to heater is 160°F (71°C). LO is suitable for standby operation.
40	FRESH/RECIRC Air Button	Allows A/C (M916A2, M917A1, and M917A1 w/ MCS), VENT, and HEAT modes to be used with recirculated or fresh air. When mode control lever is at HEAT/DEF or DEF, system draws in fresh air regardless of button setting. When MAX A/C is selected, system draws recirculated air regardless of button setting.
41	Fan Switch	Controls four-speed fan. Positions are OFF, 1,2,3, and 4. All the way clockwise is maximum fan speed.

2-2. INSTRUMENT PANEL (Con't).

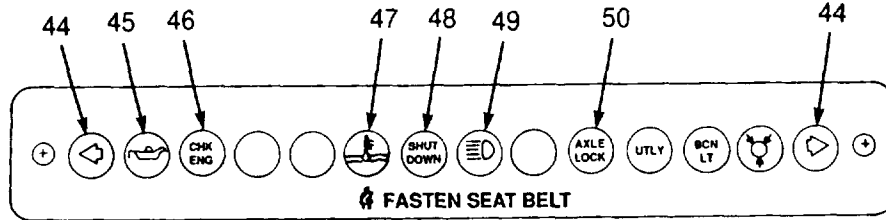


Key	Control or Indicator	Function
42	Mode Control Lever	Allows selection of modes of operation: (a) Vehicles with air conditioning. Modes are MAX A/C, A/C, VENT, HEAT, HEAT/DEF, and DEF. (b) Vehicles without air conditioning. Modes are VENT, HEAT, HEAT/DEF, and DEF.
43	Temperature Control Lever	Allows selection of a full range of temperatures from COOL to WARM.



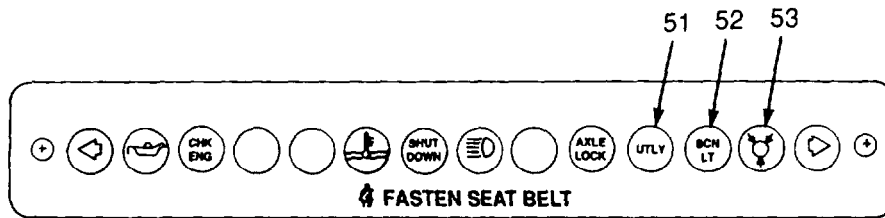
**2-2. INSTRUMENT PANEL (Con't).**

**e. Indicator and Warning Lamps.**



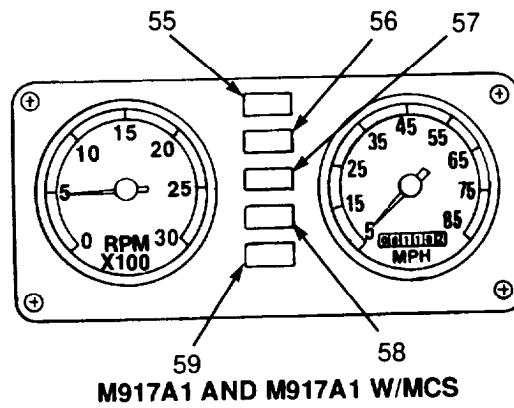
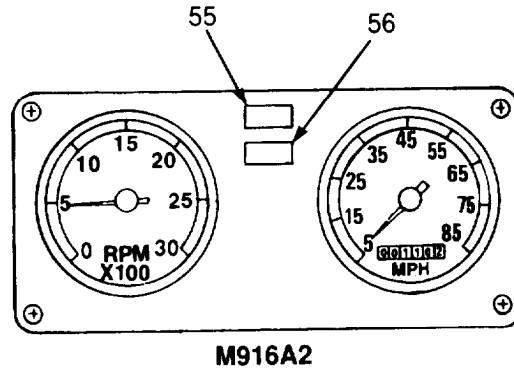
Key	Control or Indicator	Function
44	Turn Signal Indicators	Left/right green light flashes whenever outside turn signal lights are flashing. Both lights flash when four-way flashers are on.
45	Engine Oil Warning Light	Red light comes on and warning buzzer sounds when engine oil pressure is below 5 psi (34 kPa).
46	Check Engine (CHK ENG) Light	Yellow light comes on for approximately five seconds when ignition switch is turned on. Light stays on if there is an engine malfunction.
47	Engine Temperature Warning Light	Red light comes on and a warning buzzer sounds when engine coolant temperature is above 225°F (107°C).
48	SHUT DOWN Light	Red light comes on for approximately five seconds when ignition switch is turned on. Light stays on when problems such as low oil pressure, low coolant, or overheating occur in engine, making it unsafe for further operation.
49	High Beam Indicator Light	Green light comes on when high beam headlights are on.
50	AXLE LOCK Light	Amber light comes on when interaxle differential lockout/all-wheel drive control valve lever is set to LOCK/ENGAGE position, or when transfer case selector is in LOW range (all except M915A2).

**2-2. INSTRUMENT PANEL (Con't).**



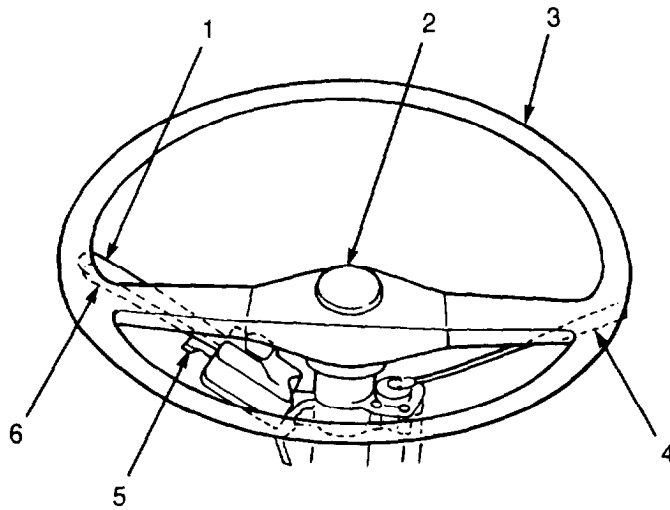
Key	Control or Indicator	Function
51	Utility (UTLY) Light (All Except M917A1 and M917A1 w/MCS)	Amber light comes on when utility lights are turned on.
52	Beacon Light (BCN LT)	Amber light comes on when beacon warning light is turned on.
53	Low Air Pressure Warning Light	Red light comes on and warning buzzer sounds when air pressure in either section of dual system falls below 65 psi (448 kPa).
55	Parking Brake Indicator Light (All Except M915A2 and M916A1)	Red light comes on when parking brakes are activated.
56	Tractor ABS (TRAC ABS) Indicator Light (All Except M915A2 and M916A1)	Red light comes on when ignition is turned ON. Once vehicle moves faster than 4 mph (6 kph), light goes out if ABS components are working. Light blinks when vehicle is in all-wheel drive.

2-2. INSTRUMENT PANEL (Con't).



Key	Control or Indicator	Function
57	Body Up Indicator Light (M917A1 and M917A1 w/MCS)	Red light comes on when dump body is raised.
58	Body (Transport) Lock Indicator Light (M917A1 and M917A1 w/MCS)	Red light comes on when dump body transport lock is locked.
59	Reduce MPH Indicator Light (M917A1 and M917A1 w/MCS)	Red light comes on when dump truck is traveling too fast for tire pressure selected by CTIS (paragraph 2-6).

**2-3. STEERING WHEEL AND COLUMN-MOUNTED CONTROLS.**

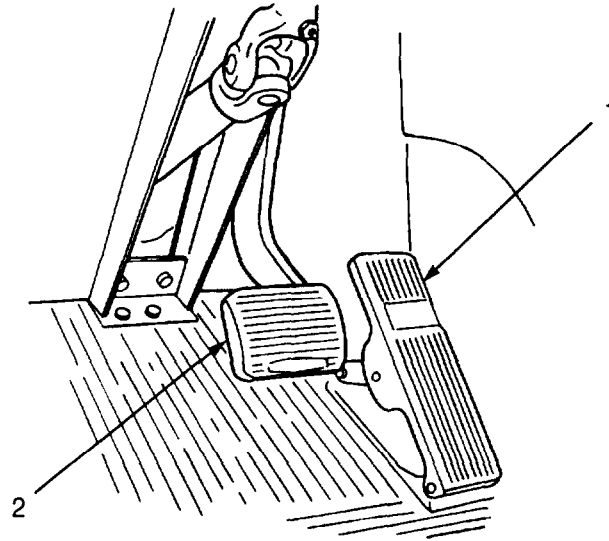


Key	Control or Indicator	Function
1	Turn Signal Lever	Move lever forward for right turn signal, rearward for left turn signal, and center for off.
2	Electric Horn	Push to activate. Used instead of air horn in normal city driving.
3	Steering Wheel	Turn clockwise to turn vehicle right and counterclockwise to turn vehicle left.
4	Trailer Brake Hand Control Valve Lever	Spring-loaded lever, when pulled rearward, activates trailer brakes.
5	Hazard Signal Switch	Located under the turn signal. Move switch out (left) to activate hazard lights. Move turn signal lever forward or rearward to deactivate hazard lights.
6	Headlight Dimmer Switch	On vehicles with serial numbers 6R-170696 and below, push button at end of turn signal lever to turn on high beams. Push button a second time to turn high beams off. On vehicles with serial numbers 6R-170697 and above, lift end of turn signal lever to turn on high beams. Lift lever again to turn high beams off.

---

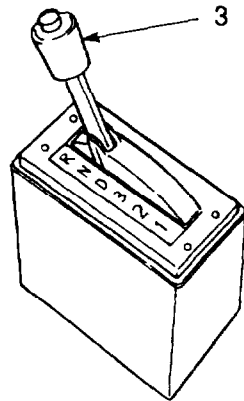
**2-4. CAB FLOOR-MOUNTED CONTROLS.**

---

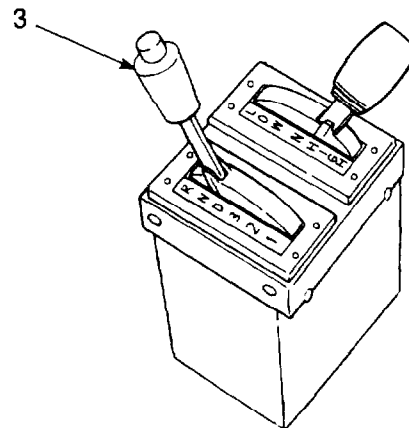


Key	Control or Indicator	Function
1	Accelerator Pedal	Depress to increase engine speed. Release to decrease engine speed.
2	Brake Pedal	Depress to apply service brakes on truck and, if properly coupled to a trailer, trailer service brakes. Release to release service brakes.

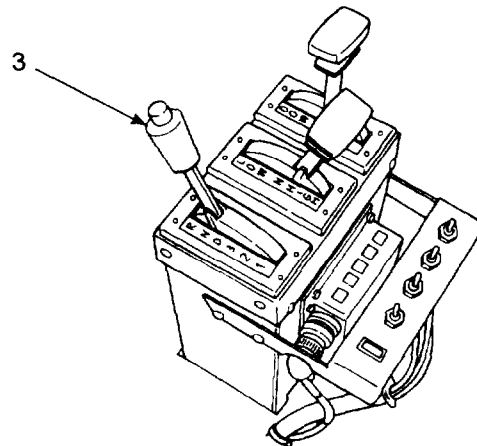
**2-4. CAB FLOOR-MOUNTED CONTROLS (Con't).**



M915A2 AND M916A1



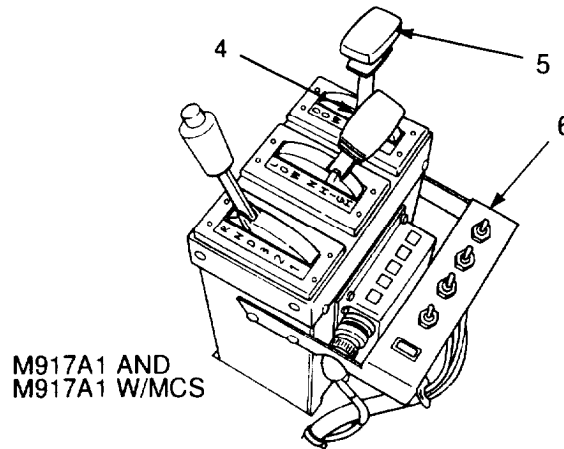
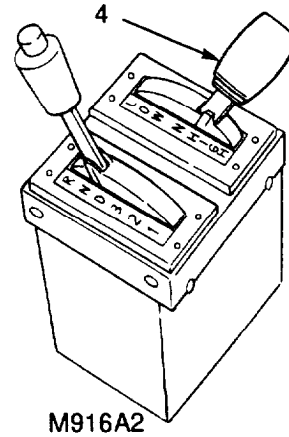
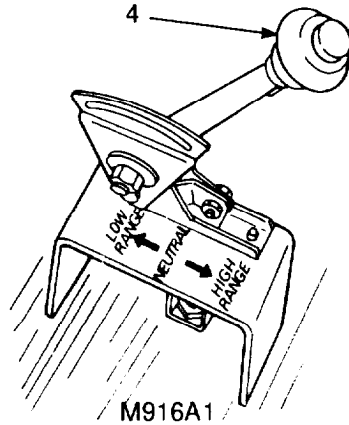
M916A2



M917A1 AND M917A1 W/MCS

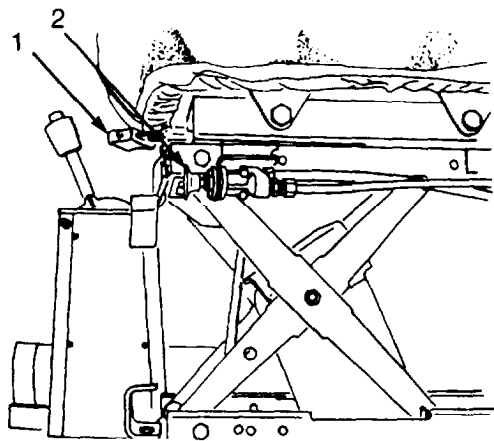
Key	Control or Indicator	Function
3	Transmission Selector Lever	Shifts automatic transmission into gear. Positions are reverse(R), neutral(N), drive(D), third gear (3), second gear (2), and first gear (1). Lever must be in neutral (N) to start truck. On M916A2, M917A1, and M917A1 w/MCS, reverse (R) activates an audio alarm when light switch is in any service position.

**2-4. CAB FLOOR-MOUNTED CONTROLS (Con't).**

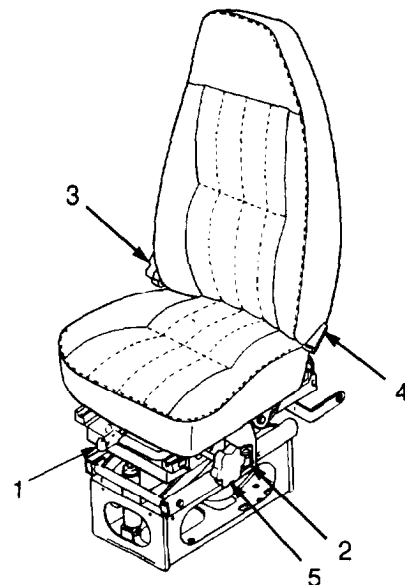


Key	Control or Indicator	Function
4	Transfer Case Selector Lever (All Except M915A2)	Shifts transfer case between LOW and HIGH range. Lever is normally left in HIGH. If left in Neutral (N) position, truck will not move. Truck must be completely stopped, with transmission in Neutral (N), before transfer case shifting is possible. Shifting selector lever to LOW also engages all-wheel drive.
5	Hydraulic Control Lever (M917A1 and M917A1 w/MCS)	Controls raising and lowering of dump body (TM 5-3805-264-14&P).
6	MCS Control Unit (M917A1 w/MCS)	Controls operation of MCS tailgate (TM 5-3805-264-14&P).

**2-5. SEAT CONTROLS.**



M915A2 AND M916A1

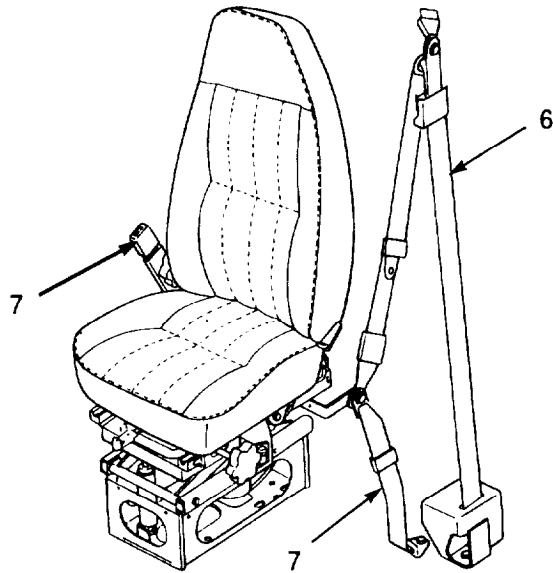


ALL EXCEPT M915A2 AND M916A1

Key	Control or Indicator	Function
1	Fore and Aft Seat Adjustment Lever	Three-position lever moves seat forward or backward. Right position locks seat in place. Moving lever all the way left adjusts seat. Traveling position is center position which provides a shock-absorbing effect.
2	Seat Height Adjustment Control Valve Lever	On M915A2 and M916A1, push in to inflate suspension and raise seat. To lower seat, pull lever out. Vehicle air pressure must be above 60 psi (414 kPa) to operate lever. On all other vehicles, push lever up to raise seat and down to lower seat.
3	Lumbar Adjustment Knob (All Except M915A2 and M916A1)	Controls lumbar support in seat. Rotate knob forward to increase and rearward to decrease lumbar support.

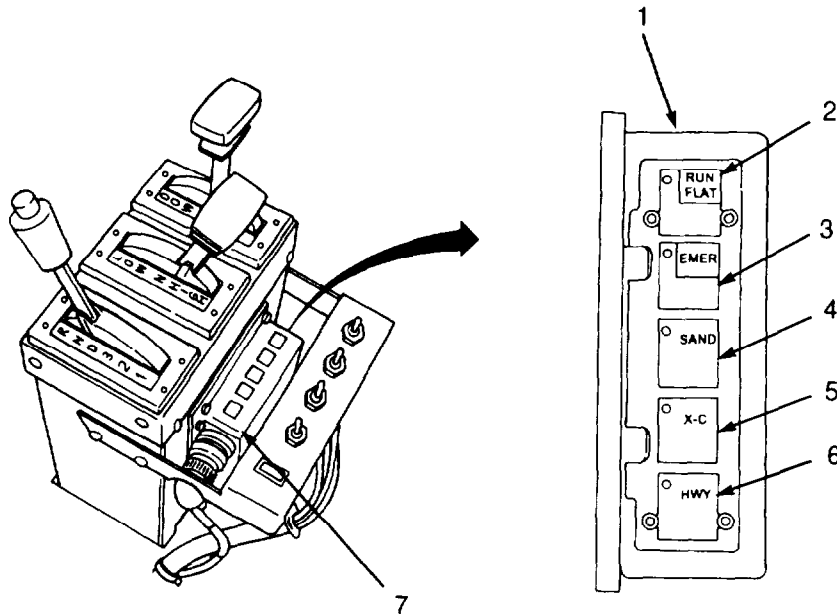


**2-5. SEAT CONTROLS (Con't).**



Key	Control or Indicator	Function
4	Seat Back Adjustment Lever (All Except M915A2 and M916A1)	Adjusts seat back angle. Apply or remove pressure from seat back and hold lever rearward to adjust.
5	Seat Cushion Tilt Adjustment Knob (All Except M915A2 and M916A1)	Rotate knob to increase or decrease seat tilt.
6	Seat Belt	Three-point belt locks into tether belt.
7	Tether Belt	Adjustable belt located on both sides of seat.

**2-6. CTIS CONTROLS AND INDICATORS (M917A1 AND M917A1 W/MCS).**



Key	Control or Indicator	Function
1	Selector Panel	Displays CTIS information and allows entry of system commands. Has four preset tire pressure mode keys and a run flat selector. Each selector push button is back-lit and has an annunciator, or system status light. This light flashes while pressures are being checked or changed and is lit steadily when selected pressure has been reached.
2	RUN FLAT Selector	Press key to check tire pressures and to inflate damaged tire every 15 seconds. Annunciator light will flash on and off in this mode. Run flat operation is limited to ten minutes unless re-selected. Press key a second time to de-select.

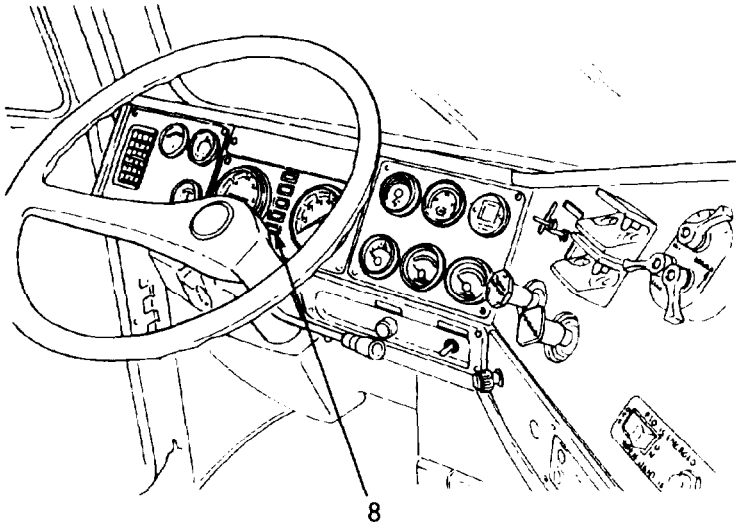
**2-6. CTIS CONTROLS AND INDICATORS (M917A1 AND M917A1 W/MCS) (Con't).**

Key	Control or Indicator	Function
3	EMER (Emergency) Mode Key	Press key to select 30 psi (207 kPa) tire pressures for operation in extreme terrain conditions where maximum traction is required, up to a maximum speed of 10 mph (16 kph). Reduce MPH indicator light will always illuminate in this mode. Operation in EMER mode is limited to 10 minutes. After ten minutes, CTIS will inflate to SAND setting unless driver re-selects EMER.
4	SAND Mode Key	Press key to select 40 psi (276 kPa) tire pressures for operation in sand, snow, and mud up to a maximum speed of 25 mph (40 kph). If 25 mph overspeed is exceeded for more than one minute, reduce MPH indicator light will flash. If exceeded for more than two minutes, CTIS will automatically inflate to cross-country (X-C) setting. There is no time limit for operation in this mode.
5	X-C (Cross-Country) Mode Key	Press key to select 55 psi (379 kPa) tire pressures for operation on non-paved secondary roads and unimproved surfaces up to a maximum speed of 40 mph (64 kph). If 40 mph overspeed is exceeded for more than one minute, reduce MPH indicator light will flash. If exceeded for more than two minutes, CTIS will automatically inflate to highway setting. There is no time limit for operation in this mode.
6	HWY (Highway) Mode Key	Press key to select 90 psi (621 kPa) tire pressures for normal operation on improved paved surfaces up to a maximum speed of 60 mph (97 kph). There is no time limit for operation in this mode.
7	Electronic Control Unit (ECU)	The control center for CTIS

---

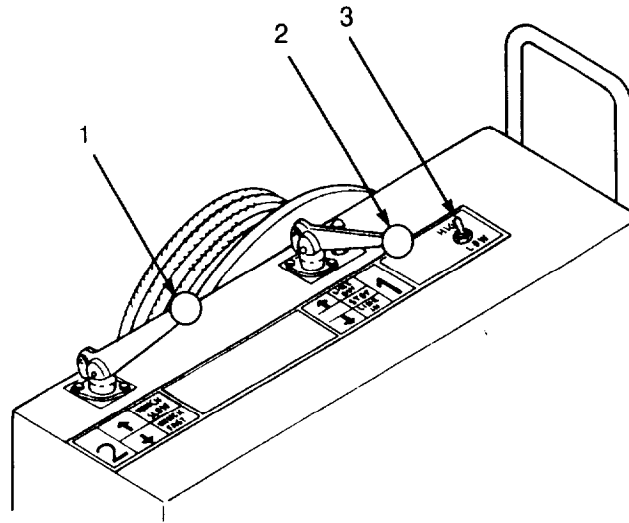
**2-6. CTIS CONTROLS AND INDICATORS (M917A1 AND M917A1 W/MCS) (Con't).**

---



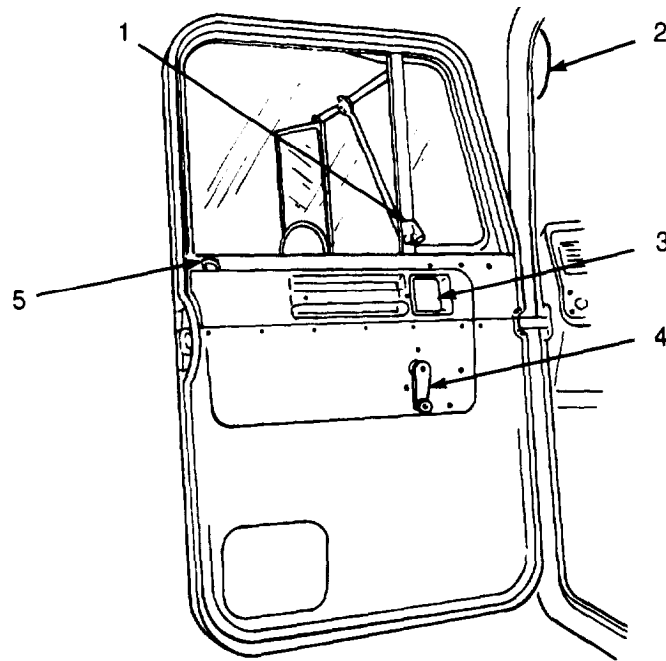
Key	Control or Indicator	Function
8	Reduce MPH Indicator Light	Red light indicates when vehicle is traveling too fast for selected mode. The following overspeed values cause light to come on: Highway - 60 mph (97 kph) Cross-Country - 40 mph (64 kph) Sand - 25 mph (40 kph) Emergency - Light always on Run Flat - No light

**2-7. WINCH CONTROLS (M916A1 AND M916A2).**



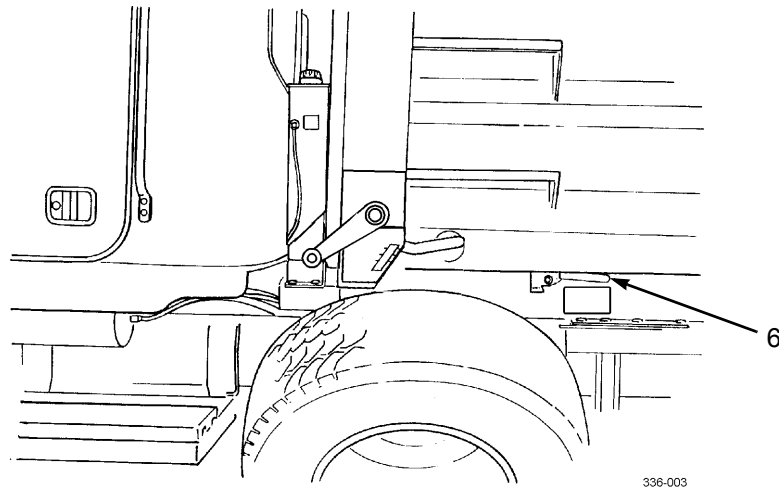
Key	Control or Indicator	Function
1	Speed Control	Controls winch speed. Push lever down for fast winch operation. Release lever for slow operation.
2	Line Control	Place lever in STOP position to apply drum brake and stop winch. Move lever to LINE OUT position to release drum brake and pay out winch cable. Move lever to LINE IN position to reel in cable.
3	Throttle Control	Two-position toggle switch controls engine speed. Move toggle switch to HIGH to increase engine speed to a maximum of 1000 rpm. Move switch to LOW to decrease engine speed.

**2-8. ADDITIONAL CONTROLS AND INDICATORS.**



Key	Control or Indicator	Function
1	Cab Vent Window Handle	Push button and raise lever to unlock window. Push out on handle to open window. Pull handle in to close window. Lower lever to lock window.
2	Air Horn Cable	Pull cable to activate air horn. Release cable to deactivate air horn.
3	Door Opening Handle	Pull handle to open cab door.
4	Door Window Glass Regulator Handle	Turn left handle clockwise to lower left window and counterclockwise to raise left window. Turn right handle counterclockwise to lower right window and clockwise to raise right window.
5	Door Lock Button	Push button down to lock door. To unlock, either pull door opening handle or unlock from outside with ignition key.

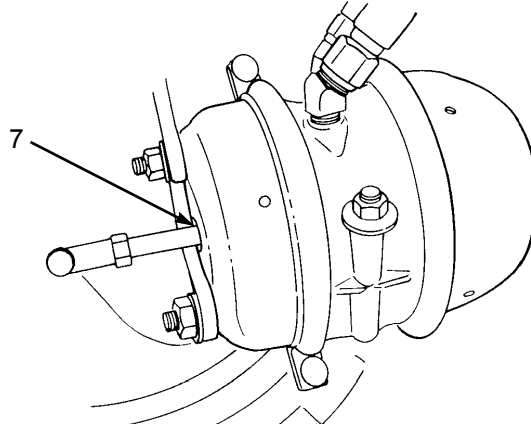
**2-8. ADDITIONAL CONTROLS AND INDICATORS (Con't).**



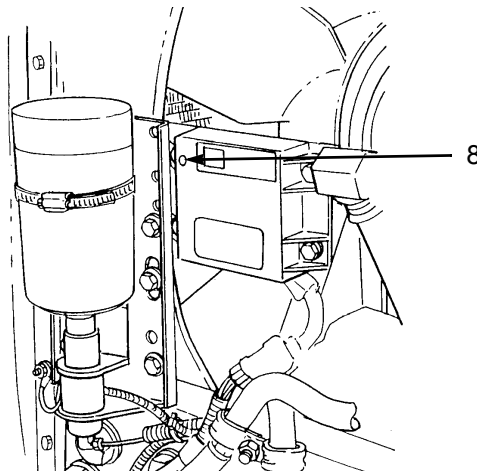
336-003

Key	Control or Indicator	Function
6	Transport Lock (M917A1 and M917A1 w/MCS)	Locks dump body to truck frame when dump truck is being transported. Locked position is at six o'clock. Normally left at three o'clock unlocked position. Do NOT raise dump body if body (transport) lock indicator light on instrument panel indicates dump body is locked (TM 5-3805-264-14&P).

**2-8. ADDITIONAL CONTROLS AND INDICATORS (Con't).**



Key	Control or Indicator	Function
7	Stroke Alert Indicator (All Except M915A2 and M916A1)	Bright orange band painted on service pushrod of all brake chambers. When visible, notify Unit Maintenance to perform stroke adjustment or major brake service.



Key	Control or Indicator	Function
8	Ether Control Relay Indicator Light (All Except M915A2 and M916A1)	Red light comes on when automatic ether injection system fuel canister is empty.



## Section II. PREVENTIVE MAINTENANCE CHECKS AND SERVICES (PMCS)

Paragraph Number	Paragraph Title	Page Number
2-9.	General .....	2-33
2-10.	Explanation of Table Entries .....	2-33
2-11.	General PMCS Procedures .....	2-34
Table 2-1.	Preventive Maintenance Checks and Services (PMCS) for M915 Family of Vehicles .....	2-37

---

### 2-9. GENERAL.

---

To ensure that the truck is ready for operation at all times, it must be inspected on a regular basis so that defects may be found and corrected before they result in serious damage, equipment failure, or injury to personnel. Table 2-1 contains systematic instructions on inspections, adjustments, and corrections to be performed by the operator/crew to keep your equipment in good operating condition and ready for its primary mission.

---

### 2-10. EXPLANATION OF TABLE ENTRIES.

---

a. **Item Number (Item No.) Column.** Numbers in this column are for reference. When completing DA Form 2404 (*Equipment Inspection and Maintenance Worksheet*), include the item number for the check/service indicating a fault. Item numbers also appear in the order that you must perform checks and services for the interval listed.

b. **Interval Column.** This column tells you when you must perform the procedure in the procedure column.

(1) Before procedures must be done immediately before you operate the truck.

(2) During procedures must be done while you are operating the truck.

(3) After procedures must be done immediately after you have operated the truck.

(4) Weekly procedures must be done once each week.

(5) Monthly procedures must be done once each month.

c. **Location. Item to Check/Service Column.** This column provides the location and item to be checked or serviced. The item location is underlined.

---

## 2-10. EXPLANATION OF TABLE ENTRIES (Con't).

---

### NOTE

The **WARNINGS** and **CAUTIONS** appearing in your PMCS table should always be observed. **WARNINGS** and **CAUTIONS** appear before applicable procedures. You must observe these **WARNINGS** to prevent serious injury to yourself and others, and **CAUTIONS** to prevent your equipment from being damaged.

d. **Procedure Column.** This column gives the procedure you must perform to check or service the item listed in the Item to Check/Service column to know if the equipment is ready or available for its intended mission or for operation. You must perform the procedure at the time stated in the interval column.

e. **Not Fully Mission Capable If: Column.** Information in this column tells you what faults will keep your equipment from being capable of performing its primary mission. If you make check and service procedures that show faults listed in this column, the equipment is not mission-capable. Follow standard operating procedures for maintaining the equipment or reporting equipment failure.

---

## 2-11. GENERAL PMCS PROCEDURES.

---

a. Always perform PMCS in the same order so it gets to be a habit. Once you've had some practice, you'll spot anything wrong in a hurry. If the truck does not perform as required, refer to the appropriate troubleshooting procedure in Chapter 3, Section II.

b. If anything looks wrong and you can't fix it, write it on your DA Form 2404. If you find something seriously wrong, IMMEDIATELY report it to your supervisor.

c. Before performing preventive maintenance, read all the checks required for the applicable interval and prepare all the tools you need to make all the checks. You'll always need a rag (Item 16, Appendix D) or two.

---

## 2-11. GENERAL PMCS PROCEDURES (Con't).

---

<b>WARNING</b>
----------------

**Dry cleaning solvent, P-D-680, is toxic and flammable. Always wear protective goggles and gloves, and use only in a well-ventilated area. Avoid contact with skin, eyes, and clothes, and DO NOT breathe vapors. DO NOT use near open flame or excessive heat. The solvent's flash point is 100°F-130°F (38°C-59°C). If you become dizzy while using cleaning solvent, immediately get fresh air and medical help. If solvent contacts eyes, immediately wash your eyes and get medical aid.**

(1) **Keep It Clean.** Dirt, grease, oil, and debris get in the way and may cover up a serious problem. Clean as you work and as needed. Use dry cleaning solvent (Item 17, Appendix D) on all metal surfaces. Use detergent (Item 4, Appendix D) and water when you clean rubber, plastic, and painted surfaces.

(2) **Rust and Corrosion.** Check metal parts for rust and corrosion. If any bare metal or corrosion exists, clean and apply a light coat of lubricating oil (Item 14, Appendix D). Report it to your supervisor.

(3) **Bolts, Nuts, and Screws.** Check bolts, nuts, and screws for obvious looseness, missing, bent, or broken condition. You can't try them all with a tool, but look for chipped paint, bare metal, or rust around bolt heads. If you find one you think is loose, tighten it.

(4) **Welds.** Look for loose or chipped paint, rust, or gaps where parts are welded together. If you find a bad weld, report it to your supervisor.

(5) **Electric Wires and Connectors.** Look for cracked or broken insulation, bare wires, and loose or broken connectors. Tighten loose connectors and ensure that the wires are in good condition.

(6) **Hoses and Fluid Lines.** Look for wear, damage, and signs of leaks. Ensure that clamps and fittings are tight. Wet spots indicate leaks, but a stain around a fitting or connector can also mean a leak. If a leak comes from a loose fitting or connector, tighten it. If something is broken or worn out, report it to your supervisor.

(7) **Fluid Leakage.** It is necessary for you to know how fluid leakage affects the status of your truck. The following are definitions of the types/classes of leakage you need to know to be able to determine the status of your truck. Learn and be familiar with them, and remember - when in doubt, notify your supervisor.

---

**2-11. GENERAL PMCS PROCEDURES (Con't).**

---

**CAUTION**

Operation is allowable with Class I and Class II leakage. **WHEN IN DOUBT, NOTIFY YOUR SUPERVISOR.** When operating with Class I or Class II leaks, check fluid levels more frequently. Class III leaks must be reported immediately to your supervisor. Failure to do this will result in damage to vehicle and/or components.

**Leakage Definitions for PMCS**

Class I	Leakage indicated by wetness or discoloration, but not great enough to form drops.
Class II	Leakage great enough to form drops, but not enough to cause drops to drip from the item being checked/inspected.
Class III	Leakage great enough to form drops that fall from the item being checked/inspected.

Table 2-1. Preventive Maintenance Checks and Services (PMCS) for M915 Family of Vehicles.

Item No.	Interval	Location	Procedure	Not Fully Mission Capable If:
		Item To Check/Service		
1	Before	<b>NOTE</b>		
		<ul style="list-style-type: none"> <li>• Review all <b>WARNINGS</b>, <b>CAUTIONS</b>, and <b>NOTES</b> before performing PMCS and operating the truck.</li> <li>• Perform all PMCS checks if:                             <ul style="list-style-type: none"> <li>a. You are the assigned operator but have not operated the truck since the last weekly inspection.</li> <li>b. You are operating the truck for the first time.</li> </ul> </li> <li>• This PMCS describes preventive maintenance, checks, and services for the chassis of an M917A1 and M917A1 w/MCS Dump Truck. Refer to TM 5-3805-264-14&amp;P for PMCS on the dump truck body.</li> </ul>		
		<b>FRONT AND LEFT SIDE</b>		
		<b>Overall View</b>	<ul style="list-style-type: none"> <li>a. Check under truck for evidence of fluid leakage such as oil, coolant, fuel, or hydraulic fluid.</li> <li>b. Check truck for obvious damage that would impair operation.</li> <li>c. Visually check for missing or damaged tires. Check lug nuts to ensure they are at least finger tight.</li> </ul>	<ul style="list-style-type: none"> <li>a. Class III oil, coolant, or hydraulic leaks or Class II fuel leaks are evident.</li> <li>b. Damage that would impair operation is evident.</li> <li>c. Any tire is missing or damaged. Lug nuts are loose or missing.</li> </ul>

**Table 2-1. Preventive Maintenance Checks and Services (PMCS)  
for M915 Family of Vehicles (Con't).**

Item No.	Interval	Location	Procedure	Not Fully Mission Capable If:
		Item To Check/Service		
2	Before	<b>Cab Exterior</b>	Check for damage to lights (9), spotting mirrors (1) side mirror (4) windshield (2) windshield wipers and blades (3), cab door (8), grabhandle (5) and battery box (7) and steps.	Damage that would interfere with visibility and impair operation is evident.
3	Before	<b>Spare Wheel and Tire</b>	Check for presence and condition of spare wheel and tire (6).	Spare wheel and tire is missing or damaged.
4	Before	<b>REAR AND RIGHT SIDE</b>	a. Check truck for obvious damage that would impair operation.  b. Visually check for missing or damaged tires. Check lug nuts to ensure they are at least finger tight.	a. Damage that would impair operation is evident.  b. Any tire is missing or damaged. Lug nuts are loose or missing.
		<b>Overall View</b>		

Table 2-1. Preventive Maintenance Checks and Services (PMCS) for M915 Family of Vehicles (Con't).

Item No.	Interval	Location	Procedure	Not Fully Mission Capable If:
		Item To Check/Service		
5		Cab Exterior	Check for damage to lights (9), side mirror (10), cab door (8), grabhandles (5), and steps (11)	Damager that would interfere with visibility and impair operation is evident.
		CAB INTERIOR		
6	Before	Instrument Panel	<p>NOTE</p> <p>Refer to Chapter 2, Section I for the location of all gages, switches, and indicator lights.</p> <p>Check for damage to gages, switches, and indicator and warning lights.</p>	Any gage is broken unreadable.

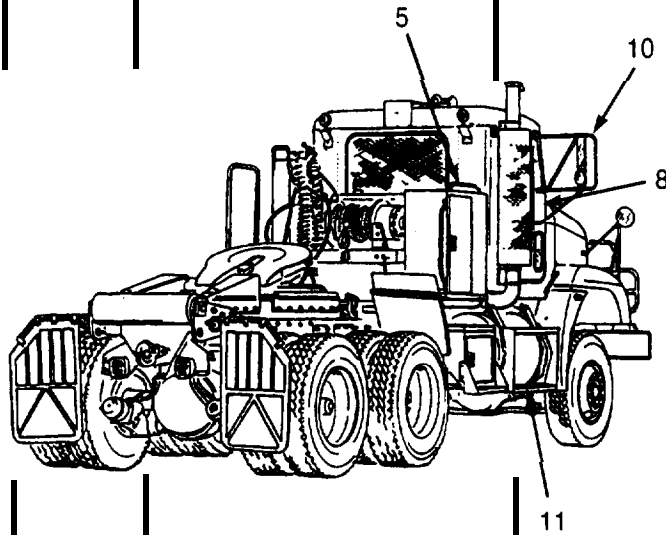


Table 2-1. Preventive Maintenance Checks and Services (PMCS) for M915 Family of Vehicles (Con't).

Item No.	Interval	Location	Procedure	Not Fully Mission Capable If:
		Item To Check Service		
7	Before	Fire Extinguisher	<p>a. Check for missing or damaged fire extinguisher (12).</p> <p>b. Check gage (13) for proper pressure of approximately 150 psi (1034 kPa).</p> <p>c. Check for damaged or missing seal (14).</p>	<p>a. Fire extinguisher is missing or damaged</p> <p>b. Pressure gage needle is in recharge area.</p> <p>c. Seal is broken or missing.</p>
8	Before	Engine Startup	<p>a. Start engine (paragraph 2-14). Verify that engine oil warning light (15), CHK ENG light (16), SHUT DOWN light (17), low air pressure warning light (18), and warning buzzer turn off.</p>	<p>a. Engine will not start. Engine oil warning light CHK ENG, SHUT DOWN, or low air pressure warning light and warning buzzer stay on.</p>



Table 2-1. Preventive Maintenance Checks and Services (PMCS) for M915 Family of Vehicles (Con't).

Item No.	Interval	Location	Procedure	Not Fully Mission Capable If:
		Item To Check Service		
8 Con't)	Before	Engine Startup	<p>The diagram shows a close-up of the instrument panel's indicator lights. Item 15 points to the oil pressure gauge, 16 to the tachometer, 17 to the tachograph, and 18 to the seat belt indicator. Below this is a larger view of the instrument panel with an arrow pointing to the same area.</p>	
			<p><b>CAUTION</b></p> <p>DO NOT run engine above idle speed until oil pressure gage indicates at least 12 psi (83 kPa) at idle speed.</p>	
9	Before	Seats and Seat Belts	<p>a. Check seats and seat belts for security of mounting and damage.</p>	<p>b. Check engine rpm on tachometer (all except M915A2 and M916A1) or on tachograph (M915A2 and M916A1).</p> <p>b. At idle, engine speed is not at 600 rpm.</p>
			<p>a. Seat belts are not serviceable.</p>	

Table 2-1. Preventive Maintenance Checks and Services (PMCS) for M915 Family of Vehicles (Con't).

Item No.	Interval	Location	Procedure	Not Fully Mission Capable If:
		Item To Check Service		
9 Con't)	Before	Seats and Seat Belts	<p style="text-align: center;"><b>NOTE</b></p> <p><b>All adjustments should be made while seated. Primary air pressure gage must indicate a minimum of 60 psi (414 kPa) to adjust height of seat.</b></p> <p>b. Check for proper operation of seat height adjustment valve lever (20) and fore and aft seat adjustment lever (19). On all vehicles except M915A2 and M916A1, check for proper operation of lumbar adjustment knob (21), seat back adjustment lever (22), and seat tilt knob (23).</p>	b. Seat missing or inoperative.

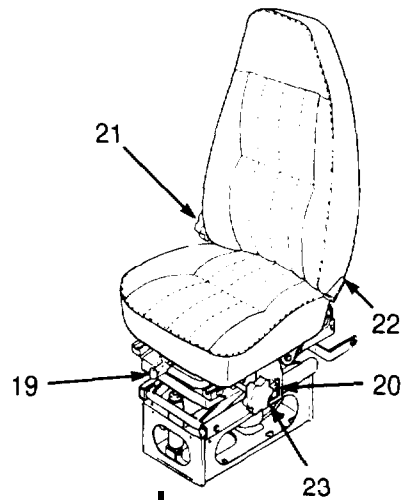
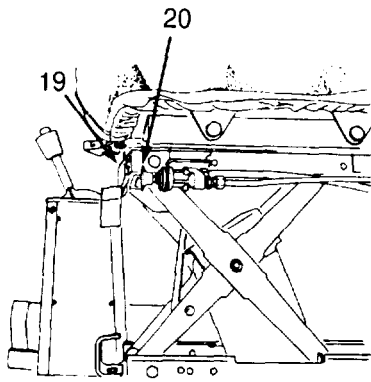


Table 2-1. Preventive Maintenance Checks and Services (PMCS)  
for M915 Family of Vehicles (Con't).

Item No.	Interval	Location	Procedure	Not Fully Mission Capable If:
		Item To Check Service		
10	Before	Side Mirrors	Adjust side mirrors as required (paragraph 2-13).	
11	Before	Instrument Panel Gages and Indicator and Warning Lights		
<p><b>CAUTION</b></p> <p>At 1760-2100 rpm, minimum engine oil pressure for safe operation is 12 psi (83 kPa). If gage does not show at least 12 psi (83 kPa), shut down engine and notify supervisor. Failure to follow this caution will damage engine.</p>				
		<p>a. Check oil pressure gage. Reading should be 12-50 psi (83-295 kPa) at idle.</p> <p>b. Check primary and secondary air pressure gages for 90-120 psi (621-827 kPa) (green band).</p> <p>c. Check that voltmeter registers within green band.</p> <p>d. On M915A2 and M916A1, check fuel pressure gage reading. Reading should be no lower than 7 psi (48 kPa).</p>	<p>a. Gage reading is not within limits.</p> <p>b. Gage reads less than 65 psi (441 kPa) (yellow band), warning buzzer stays on or gage is not operating.</p> <p>c. Needle is in yellow or red band.</p> <p>d. Reading is below 7 psi (48 kPa).</p>	

**Table 2-1. Preventive Maintenance Checks and Services (PMCS)  
for M915 Family of Vehicles (Con't).**

Item No.	Interval	Location	Procedure	Not Fully Mission Capable if:
		Item To Check/Service		
11 (Con't)	Before	Instrument Panel Gages and Indicator and Warning Lights	<p>e. Check that fuel supply gage registers and indicates adequate fuel for mission.</p> <p>Check air cleaner restriction indicator.</p> <p>g. Check that ABS warning light is lit.</p> <p>h. On M917A1 and M917A1 w MCS, verify that CTIS system is operational with no malfunctions indicated on selector panel (paragraph 2-17).</p>	<p>f. On M915A2, indicator window shows yellow. On all other models, indicator window shows 20 in. of water.</p> <p>h. Mission requires use of CTIS and CTIS does not have system power or is malfunctioning.</p>
12	Before	Parking Brake	With service brake pedal depressed, transmission in Drive (D), and engine at idle pull out on parking brake valve, then release service brake pedal. Vehicle should not move.	Vehicle moves with parking brake applied.
13	Before	Service Brakes	With transmission in Drive (D), release parking brake and apply service brakes. Vehicle should not move.	Vehicle moves with service brakes applied.
14	Before	Transmission Controls	With service brakes applied, move transmission selector lever through all gears and check for smooth operation.	Operation is no smooth or there is binding between gears.

Table 2-1. Preventive Maintenance Checks and Services (PMCS) for M915 Family of Vehicles (Con't).

Item No.	Interval	Location	Procedure	Not Fully Mission Capable If:
		Item To Check/Service		
15	Before	Trailer Brakes	<p style="text-align: center;"><b>NOTE</b></p> <p style="text-align: center;"><b>Perform this check with trailer after tractor/trailer are coupled.</b></p> <p>a. Listen for air leaks at intervehicular connecting hoses, relay valve, and air reservoirs.</p> <p>b. Apply trailer brakes only and attempt to move tractor/trailer combination.</p>	<p>a. Any air leaks are present.</p> <p>b. Brakes fail to hold tractor/trailer combination from moving.</p>
16	During	Instrument Panel	<p>a. Monitor all gages and indicator and warning lights. Check that engine coolant, transmission oil, and transfer case (all except M915A2) oil temperature gages register within normal range (green band).</p> <p>b. On M915A2 and M916A1, check that fuel pressure gage reads 35-65 psi (241-448 kPa).</p>	<p>a. Any temperature or pressure gage does not register or indicates abnormal reading.</p> <p>b. Gage reads less than 35 psi (241 kPa).</p>
17	During	Brakes	<p>a. Check brakes for pulling or grabbing.</p> <p>b. Check that brake pedal is firm and does not fully depress to floor.</p>	<p>a. Brakes pull or grab.</p> <p>b. Brake pedal is spongy or depresses fully to floor.</p>

Table 2-1. Preventive Maintenance Checks and Services (PMCS) for M915 Family of Vehicles (Con?).

Item No.	Interval	Location	Procedure	Not Fully Mission Capable If:
		Item To Check/Service		
18	During	Steering	Check for smooth steering without pulling to one side or excessive play [more than 2½ in. (6.4 cm)] in steering wheel.	Steering is erratic, pulls, or has excessive play.
19	During	Power Train	a. Check for unusual noise or vibration from engine, transmission, transfer case (all except M915A2), drive shafts, axles, and wheels. b. Check for smooth operation of transfer case selector (all except M915A2).	a. Unusual noise or vibration is present. b. Selector shifts with difficulty or there is unusual noise.
20	During	Winch (M916A1 and M916A2)	<div style="text-align: center; border: 1px solid black; padding: 5px; width: fit-content; margin: 0 auto;"> <b>WARNING</b> </div> <p><b>Always wear heavy gloves when handling winch wire rope. Never allow cable to run through hands, as injury may result.</b></p>	
			a. Check cable for kinks, frays, and breaks in wire. Check for inadequate lubrication or corrosion. As required, clean and lubricate cable when mission is complete (Appendix F). b. Check winch for proper control response.	a. Cable is damaged or missing. b. There is no control response.

Table 2-1. Preventive Maintenance Checks and Services (PMCS)  
for M915 Family of Vehicles (Con't).

Item No.	Interval	Location	Procedure	Not Fully Mission Capable If:
		Item To Check/Service		
21	During	Air Conditioner (All Except M915A2 and M916A1)	<p style="text-align: center;"><b>NOTE</b></p> <p>Perform the following inspection only if air conditioner is required due to climatic conditions.</p> <p>Turn air conditioner on and set blower to maximum cooling speed settings. Wait five minutes to allow temperature to stabilize. Check outlet ducts for cool air. If air is not cooler than ambient temperature, notify supervisor.</p>	
22	During	Overall Leakage	Be alert for evidence of fluid leakage.	Class III oil, coolant or hydraulic leaks or Class II fuel leak are evident.
		FRONT AND LEFT SIDE		
23	After	Overall View	<p>a. Check under truck for evidence of fluid leakage such as oil, coolant, fuel, or hydraulic fluid.</p> <p>b. Check front gladhands for damage. Ensure that gladhand vent holes are not plugged. Ensure that dummy couplings are installed.</p>	a. Class III oil, coolant, or hydraulic leaks or Class II fuel leaks are evident.

Table 2-1. Preventive Maintenance Checks and Services (PMCS)  
for M915 Family of Vehicles (Con't).

Item No.	Interval	Location	Procedure	Not Fully Mission Capable If:
		Item To Check/Service		
23 Con't)	After	Overall View	c. Check truck for obvious damage that would impair operation.  d. Check for damage to front service and blackout lights and marker clearance lights.	c. Damage that would impair operation is evident.  d. Lights are damaged.
24	After	Wheels and Tires	<div style="border: 1px solid black; padding: 5px; display: inline-block;"><b>WARNING</b></div> <b>Operating truck with an underinflated or defective tire may lead to tire failure and loss of steering control. Damage to equipment or injury to personnel may result.</b>	
			a. Visually check all left side tires for defects, underinflation, or loose or missing wheel studs or lug nuts.  b. For M917A1 and M917A1 w/ MCS, check for damage to CTIS hoses (25) wheel valves (26) and fittings (24) at wheels.	a. Tire is missing, deflated, unserviceable, or two or more wheel studs or lug nuts are missing.  b. CTIS components are damaged.



Table 2-1. Preventive Maintenance Checks and Services (PMCS)  
for M915 Family of Vehicles (Con't).

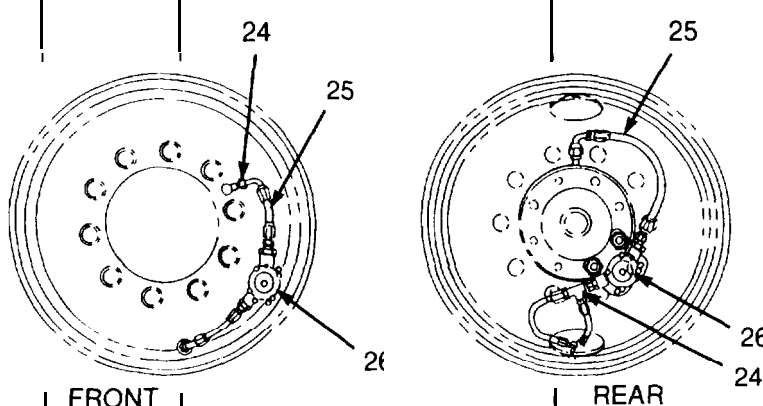
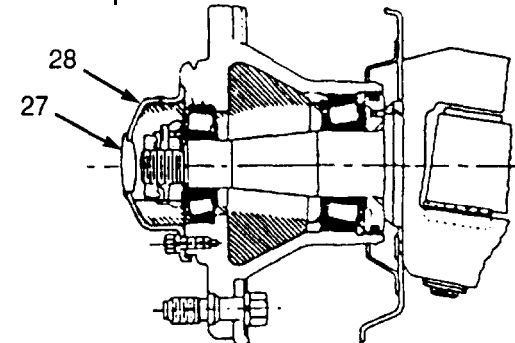
Item No.	Interval	Location	Procedure	Not Fully Mission Capable If:
		Item To Service		
24 (Con't)	After	Wheels and Tires	 <p>FRONT</p> <p>REAR</p>	
25	After	Front Axle Wheel Bearings (M915A2)	<p>Check that lubricating oil is visible in sight glass (28) and rubber plug (27) is installed. If oil is not visible in sight glass, remove plug and add until level is even with plug opening (Appendix F).</p> 	

Table 2-1. Preventive Maintenance Checks and Services (PMCS)  
for M915 Family of Vehicles (Con't).

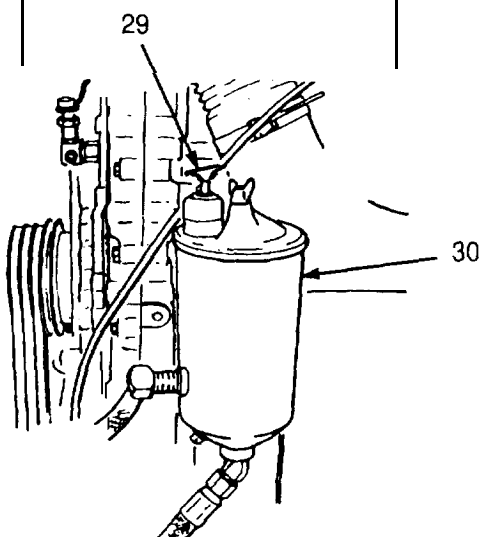
Item No.	Interval	Location	Procedure	Not Fully Mission Capable If:
		Item To Check/Service		
26	After	Power Steering Reservoir	<p>With fluid at operating temperature and engine running, remove dipstick (29) and check level of power steering fluid in reservoir (30). Add fluid as required if level is below add mark (Appendix F).</p> 	

Table 2-1. Preventive Maintenance Checks and Services (PMCS) for M915 Family of Vehicles (Con't).

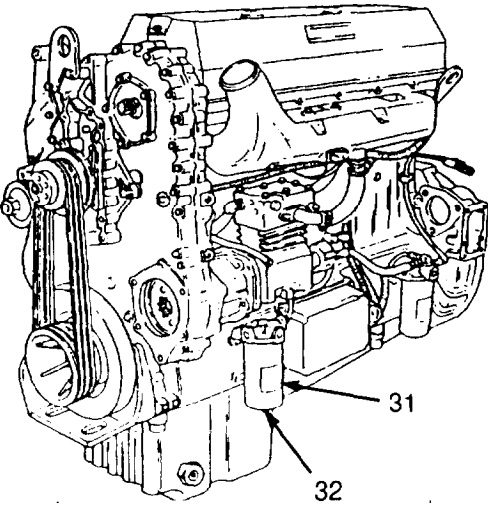
Item No.	Interval	Location	Procedure	Not Fully Mission Capable if:
		Item To Check/Service		
27	After	Fuel Filter/Water Separator	<div style="border: 1px solid black; padding: 5px; text-align: center; margin: 10px auto; width: fit-content;"> <b>WARNING</b> </div> <p>DO NOT perform fuel system checks, inspections, or maintenance while smoking or near fire, flames, or sparks. Fuel may ignite, causing damage to vehicle and injury or death to personnel.</p> <div style="text-align: center; margin: 10px auto;"> <b>NOTE</b> </div> <p>Ensure that a suitable container is used to catch fluid.</p> <p>Turn drain knob (32) counterclockwise and drain all water from fuel filter/water separator (31). Turn knob clockwise to close.</p> 	

Table 2-1. Preventive Maintenance Checks and Services (PMCS)  
for M915 Family of Vehicles (Con't).

Item No.	Interval	Location	Procedure	Not Fully Mission Capable if:
		Item To Check/Service		
28	After	Intervehicular Air Hoses and Electrical Connectors (All Except M917A1 and M917A1 w/MCS)	Check for presence and general condition of intervehicular air hoses (33), gladhands (34), gladhand preformed packings (35), and electrical connectors (36).	Air hose, gladhand, or electrical connector is damaged.

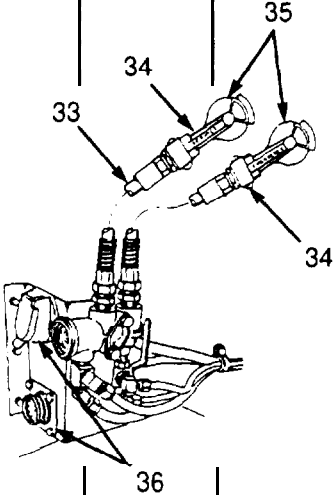
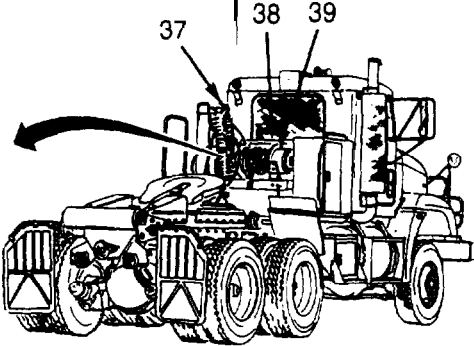



Table 2-1. Preventive Maintenance Checks and Services (PMCS) for M915 Family of Vehicles (Con't).

Item No.	Interval	Location	Procedure	Not Fully Mission Capable If:
		Item To Check/Service		
29	After	Winch (M916A1 and M916A2)	<p>a. Inspect winch reservoir (38), lines and fittings, drum (39), and controls (37) for leaks or damage.</p> <p>b. Check level of lubricating oil in reservoir (38). Level is low if not visible or if just visible in lower sight indicator (40). Add oil as required by removing filler cap (42) and adding oil until visible in top sight indicator (41). Ensure that strainer (43) is clean before installing filler cap</p>	a. Damage that would impair operation or Class III leaks are evident.

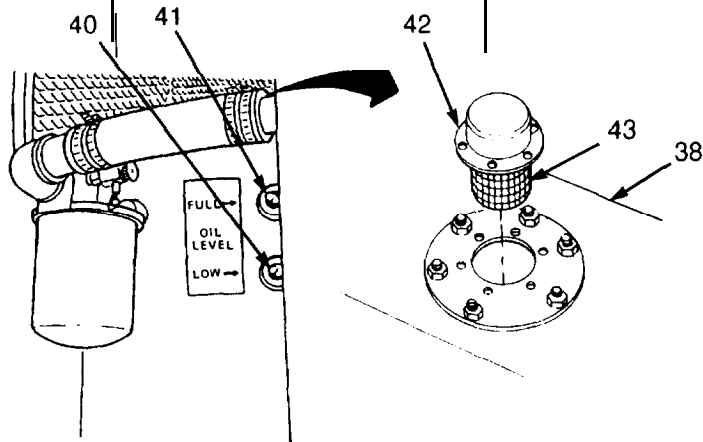


Table 2-1. Preventive Maintenance Checks and Services (PMCS) for M915 Family of Vehicles (Con't).

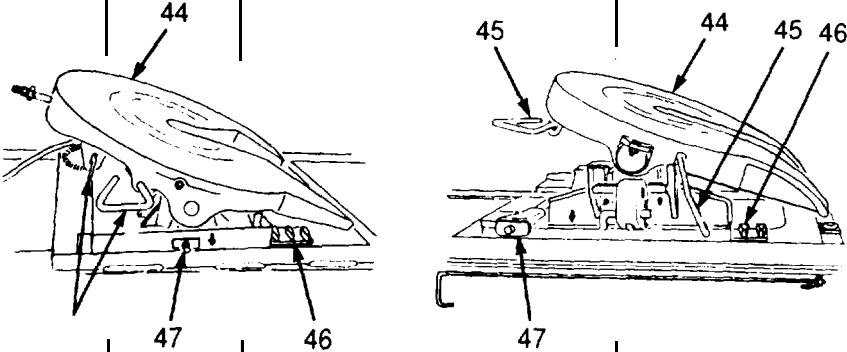
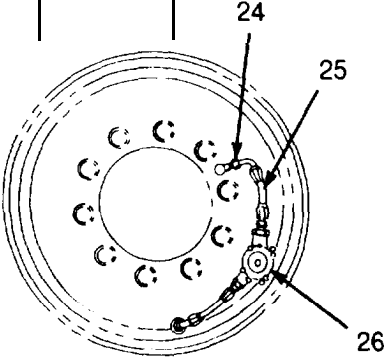
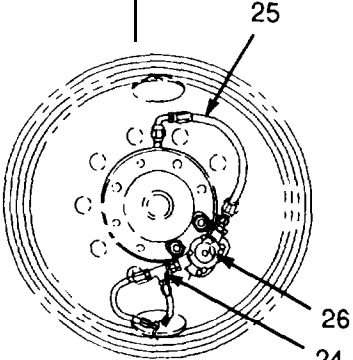
Item No.	Interval	Location	Procedure	Not Fully Mission Capable if:
		Item To Check/Service		
30	After	Fifth Wheel (All Except M917A1 and M917A1 w/MCS)	<div style="border: 1px solid black; padding: 5px; text-align: center; margin: 10px auto; width: fit-content;"> <b>WARNING</b> </div> <p>Failure to keep fifth wheel plate lubricated could cause erratic steering due to binding of plate between tractor and trailer. This could result in an accident, causing injury to personnel.</p> <ol style="list-style-type: none"> <li>a. Check that fifth wheel plate (44) is coated with grease.</li> <li>b. Check for operation and damage to lock release levers (45), slide locking plungers (47), sliding rails (46), and fifth wheel plate (44).</li> </ol>	<p>b. Lock release levers do not operate. Locking jaw mechanism is cracked or worn.</p>
				

Table 2-1. Preventive Maintenance Checks and Services (PMCS)  
for M915 Family of Vehicles (Con't).

Item No.	Interval	Location	Procedure	Not Fully Mission Capable if:
		Item To Check/Service		
31	After	REAR AND RIGHT SIDE	<ul style="list-style-type: none"> <li>a. Check under truck for evidence of fluid leakage such as oil, coolant, fuel, or hydraulic fluid.</li> <li>b. Check rear gladhands for damage. Ensure that gladhand vent holes are not plugged. Ensure that dummy couplings are installed.</li> <li>c. Check truck for obvious damage that would impair operation.</li> <li>d. Check for damage to rear service and blackout lights and marker clearance lights.</li> <li>e. Check for damage to exhaust system components. Ensure that components are securely mounted and are not leaking.</li> </ul>	<ul style="list-style-type: none"> <li>a. Class III oil, coolant, or hydraulic leaks or Class II fuel leaks are evident.</li> <li>c. Damage that would impair operation is evident.</li> <li>d. Lights are damaged.</li> <li>e. Exhaust system components are damaged.</li> </ul>
		Overall View		

Table 2-1. Preventive Maintenance Checks and Services (PMCS) for M915 Family of Vehicles (Con't).

Item No.	Interval	Location	Procedure	Not Fully Mission Capable if:
		Item To Check/Service		
32	After	Wheels and Tires	<div style="text-align: center; border: 1px solid black; padding: 5px; width: fit-content; margin: 0 auto;"> <b>WARNING</b> </div> <p>Operating truck with an underinflated or defective tire may lead to tire failure and loss of steering control. Damage to equipment or injury to personnel may result.</p> <p>a. Visually check all right side tires for defects, underinflation, or loose or missing wheel studs or lug nuts.</p> <p>b. For M917A1 and M917A1 w/ MCS, check for damage to CTIS hoses (25), wheel valves (26) and fittings (24) at wheels.</p> <div style="display: flex; justify-content: space-around; align-items: center;"> <div style="text-align: center;">  <p>FRONT</p> </div> <div style="text-align: center;">  <p>REAR</p> </div> </div>	



**Table 2-1. Preventive Maintenance Checks and Services (PMCS)  
for M915 Family of Vehicles (Con't).**

Item No.	Interval	Location	Procedure	Not Fully Mission Capable If:
		Item To Check/Service		
38	After	Fifth Wheel Ramps (All Except M917A1 and M917A1 w/MCS)	Check for damage to fifth wheel ramps (53).	Damage that prevents coupling.
39	After	Fifth Wheel Roller (M916A1 and M916A2)	Check for damage to roller (52).	Damage that prevents coupling.
40	After	Taillights	Check for damage to taillights (49).	Taillights are damaged.
41	After	Trailer Gladhands	Check for presence of dummy couplings (50) and damage to trailer gladhands (48).	Damage that prevents air from applying trailer brakes when coupled.
42	After	Mud Flaps	Check for presence and general condition of mud flaps (51).	Mud flaps are missing.

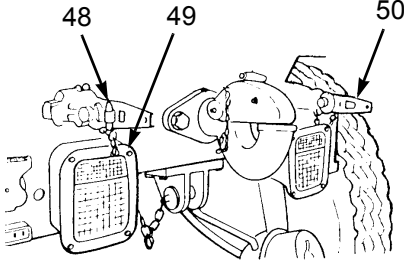
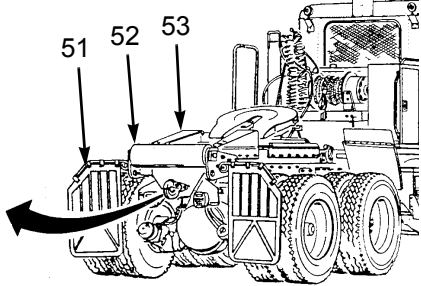



Table 2-1. Preventive Maintenance Checks and Services (PMCS)  
for M915 Family of Vehicles (Con't).

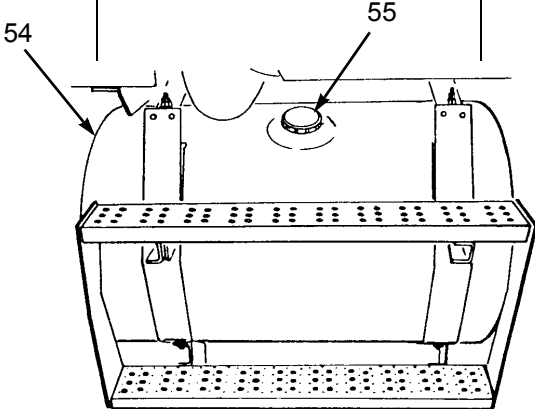
Item No.	Interval	Location	Procedure	Not Fully Mission Capable If:
		Item To Check/Service		
43	After	Fuel Tank	<div style="text-align: center; border: 1px solid black; padding: 5px; width: fit-content; margin: 0 auto;">WARNING</div> <p><b>DO NOT</b> smoke or permit any open flame in area of truck while servicing diesel fuel system. Be sure hose nozzle is grounded against filler tube during refueling to prevent static electricity. Failure to follow this warning may result in injury to personnel or equipment damage.</p> <p>a. Check for presence and condition of fuel filler cap (55).</p> <p>b. Check fuel tank (54) for leaks, damage, and security of mounting.</p>	<p>a. Filler cap is missing or damaged.</p> <p>b. Class III fuel leaks are evident.</p>
				

Table 2-1. Preventive Maintenance Checks and Services (PMCS) for M915 Family of Vehicles (Con't).

Item No.	Interval	Location		Procedure	Not Fully Mission Capable If:
		Item To Check/Service			
38 (Con't)	After	Fuel Tank		c. Remove fuel tank filler cap (55) and fill fuel tank (54) to holes [approximately 3 in. (7.6 cm)] in filler neck. Ensure that filler cap is free of debris and other material that could interfere with air venting. Install filler cap.	
39	After	Front Axle Wheel Bearings (M915A2)		Check that lubricating oil is visible in sight glass (28) and rubber plug (27) is installed. If oil is not visible in sight glass, remove plug and add until level is even with plug opening (Appendix F).	

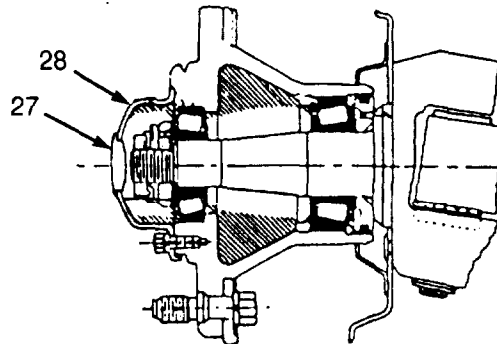


Table 2-1. Preventive Maintenance Checks and Services (PMCS)  
for M915 Family of Vehicles (Con't).

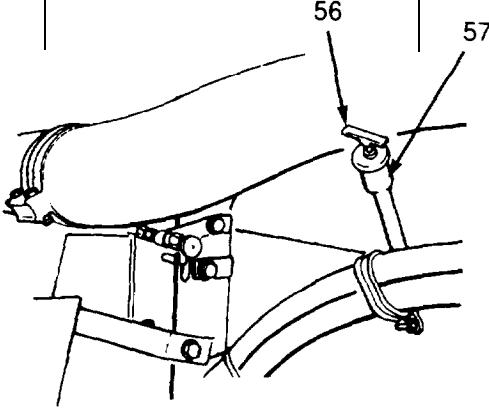
Item No.	Interval	Location	Procedure	Not Fully Mission Capable if:
		Item To Check/Service		
40	After	Transmission	<p>Start engine and run at idle with transmission in Neutral (N) until transmission oil temperature gage registers 60-120°F (16-49°C). Perform cold oil check (Appendix F). When temperature has reached 160-200°F (71-93°C) perform hot oil check (Appendix F). Add transmission fluid as required through fill tube (57) until level on dipstick (56) is correct (Appendix F). Shut down engine.</p> 	

Table 2-1. Preventive Maintenance Checks and Services (PMCS)  
for M915 Family of Vehicles (Con't).

Item No.	Interval	Location	Procedure	Not Fully Mission Capable if:
		Item To Check/Service		
41	After	Air Reservoirs	<p style="text-align: center;"><b>NOTE</b></p> <p>Perform the following service at all air reservoirs.</p> <p>Open air reservoir drain valve (58) using cable pulls if present, and allow all air and liquid condensation to drain. When fully drained, close drain valve.</p>	

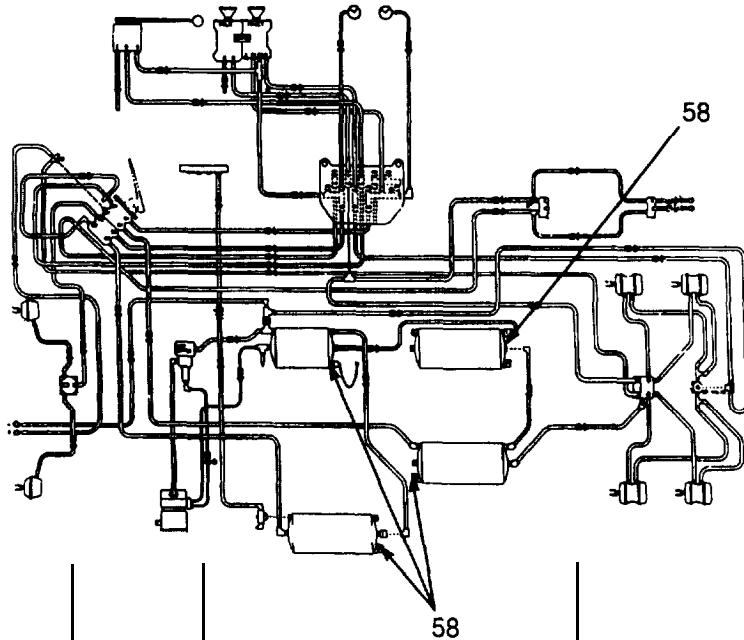


Table 2-1. Preventive Maintenance Checks and Services (PMCS)  
for M915 Family of Vehicles (Con't).

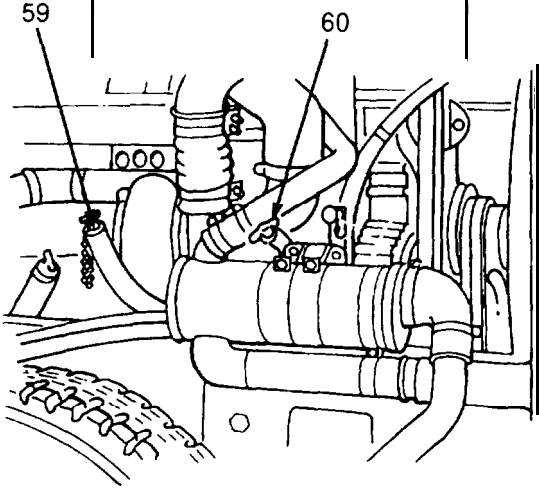
Item No.	Interval	Location	Procedure	Not Fully Mission Capable If:
		Item To Check/Service		
42	After	Engine Crankcase	<p><b>NOTE</b></p> <p>To ensure an accurate reading, vehicle must be parked on level ground. Wait 10 minutes after shutting down engine to allow oil to drain into crankcase.</p> <p>Remove dipstick (60) and check level of lubricating oil. Safe operating level is between ADD and FULL marks on dipstick. If level is low, add oil through filler opening (59) until level on dipstick is correct (Appendix F).</p>	
				

Table 2-1. Preventive Maintenance Checks and Services (PMCS)  
for M915 Family of Vehicles (Con't).

Item No.	Interval	Location	Procedure	Not Fully Mission Capable If:
		Item To Check/		
43	After	Radiator	<div style="border: 1px solid black; padding: 5px; text-align: center; margin-bottom: 10px;"><b>WARNING</b></div> <p><b>DO NOT</b> remove radiator cap unless engine is cold. Remove cap in two steps. First, place thick cloth over cap and slowly turn cap left to first stop. Pause and allow pressure to escape. Turn cap further left until it can be removed. This is a pressurized cooling system and escaping steam, hot water or coolant will cause serious burns.</p> <p>Remove radiator cap (61) and check coolant level in radiator (62). Coolant must be within 2½ in. (6.4 cm) below filler neck. Add coolant as required (Appendix F).</p>	

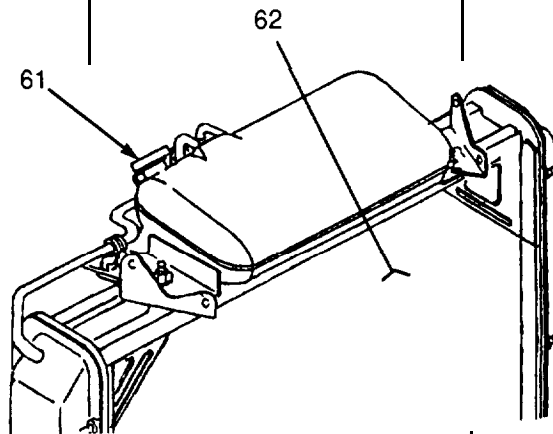


Table 2-1. Preventive Maintenance Checks and Services (PMCS)  
for M915 Family of Vehicles (Con't).

Item No.	Interval	Location	Procedure	Not Fully Mission Capable If:
		Item To Check/Service		
44	After	Horns	<p><b>NOTE</b></p> <p>Vehicle operation with Inoperative horn may violate AR 385-55.</p> <p>If tactical situation permits, check operation of electrical and air horns.</p>	
45	After	Accessory Items	<p>Verify that windshield wipers and heater/ventilator or air conditioner, if equipped, operate.</p>	
46	After	Lights	<p><b>NOTE</b></p> <p>Vehicle operation with damaged or inoperative headlights or stoplights may violate AR 385-55.</p> <p>a. Check for presence and operation of service drive, turn signal, blackout marker, marker, blackout drive, and marker clearance lights.</p> <p>b. Check operation of tail/stoplights. Depress brake pedal approximately <math>\frac{1}{4}</math> in. (6.4 mm). Tail/stoplights should come on.</p>	



Table 2-1. Preventive Maintenance Checks and Services (PMCS)  
for M915 Family of Vehicles (Con't).

Item No.	Interval	Location	Procedure	Not Fully Mission Capable If:
		Item To Check/Service		
47	Weekly	FRONT AND LEFT SIDE	<p>a. Check for loose, missing, broken, frayed, or cracked drive belts (64). Notify supervisor if loose drive belts are suspected.</p> <p>b. Check for damaged pulleys (63).</p>	<p>a. Any drive belt is loose, missing, broken, cracked to the belt fiber, has more than one crack 1/8 in. (3.2 mm) in depth, or has frays more than 2 in. (5.1 cm) long.</p> <p>b. Pulley is damaged.</p>
		Drive Belts		

The diagram shows a front view of an engine compartment. Callout 63 points to several pulleys of different sizes. Callout 64 points to the drive belts that loop around these pulleys. The belts are shown in a cross-section view, highlighting their structure and how they are tensioned.

Table 2-1. Preventive Maintenance Checks and Services (PMCS)  
for M915 Family of Vehicles (Con't).

Item No.	Interval	Location	Procedure	Not Fully Mission Capable if:
		Item To Check/Service		
48	Weekly	Ether Quick-Start System	<div style="border: 1px solid black; padding: 5px; text-align: center; margin: 10px auto; width: fit-content;"> <b>WARNING</b> </div> <p>Ether is highly flammable and explosive. DO NOT perform ether quick-start system checks or inspections while smoking or near fire, flame, or sparks. Failure to follow this warning may cause a fire and explosion, causing serious injury or death to personnel.</p> <ul style="list-style-type: none"> <li>a. Check for loose connections and damage to lines, fittings, and canister. Be alert for the odor of leaking ether.</li> <li>b. On vehicles equipped with an automatic ether quick-start system, check that red indicator light on ether control relay is not on, when vehicle has power.</li> </ul>	<ul style="list-style-type: none"> <li>a. Damage or leakage is evident.</li> <li>b. Red indicator light is on.</li> </ul>

Table 2-1. Preventive Maintenance Checks and Services (PMCS)  
for M915 Family of Vehicles (Con't).

Item No.	Interval	Location	Procedure	Not Fully Mission Capable If:
		Item To Check/Service		
49	Weekly	Front Wheel and Tire	<div style="border: 1px solid black; padding: 5px; text-align: center; margin: 10px auto; width: fit-content;"> <b>WARNING</b> </div> <p>Operating truck with an underinflated or defective tire may lead to tire failure and loss of steering control. Damage to equipment or injury to personnel may result.</p> <p style="text-align: center;"><b>NOTE</b></p> <p><b>M917A1 and M917A1 w/MCS CTIS must be in highway (HWY) mode for this check.</b></p> <p>a. Check pressure in tires and adjust as required:</p> <p>M915A2 (Empty) - 85 psi (586 kPa)  M915A2 (Loaded) - 105 psi (724 kPa)  M916A1/M916A2 (Empty) - 100 psi (690 kPa)  M916A1/M916A2 (Loaded) - 115 psi (793 kPa)  M917A1/M917A1 w/MCS - 90 psi (621 kPa)</p> <p>b. Ensure all wheel stud lug nuts are tight using wheel stud lug nut wrench and handle.</p> <p>c. Check wheel for cracks, breaks, or bends.</p>	<p>b. Any wheel stud is missing or lug nut is loose.</p> <p>c. Wheel is cracked broken, or bent.</p>

Table 2-1. Preventive Maintenance Checks and Services (PMCS)  
for M915 Family of Vehicles (Con't).

Item No.	Interval	Location	Procedure	Not Fully Mission Capable If:		
		Item To Check/Service				
50	Weekly	Batteries	<div style="text-align: center; border: 1px solid black; padding: 5px; width: fit-content; margin: 0 auto;"> <b>WARNING</b> </div> <p>To avoid eye injury, eye protection is required when working around batteries. Do not smoke, use open flame, make sparks, or create other ignition sources around batteries. If a battery is giving off gases, it can explode and cause injury to personnel. Remove all jewelry, such as rings, ID tags, watches, and bracelets. If jewelry or a tool contacts a battery terminal, a direct short will result in an instant heating, damage to equipment, and injury to personnel.</p> <div style="text-align: center; border: 1px solid black; padding: 5px; width: fit-content; margin: 20px auto;"> <b>CAUTION</b> </div> <p>To reduce battery damage, do not remove batteries from vehicle/equipment battery compartment unless the battery compartment is corroded (greenish/white powder). Do not jerk or pull on battery cables during visual inspection. Battery replacement will be performed by Unit Maintenance personnel.</p> <table border="0" style="width: 100%; border-collapse: collapse;"> <tr> <td style="width: 50%; border-right: 1px solid black; padding: 5px; vertical-align: top;">                     a. Release latches (68) and remove cover (65). Check battery compartment for damaged or missing batteries.                       b. Check for damaged or missing filler caps (66).                 </td> <td style="width: 50%; padding: 5px; vertical-align: top;">                     a. One or more batteries are damaged or missing.                       b. One or more filler caps are damaged or missing.                 </td> </tr> </table>	a. Release latches (68) and remove cover (65). Check battery compartment for damaged or missing batteries.  b. Check for damaged or missing filler caps (66).	a. One or more batteries are damaged or missing.  b. One or more filler caps are damaged or missing.	
a. Release latches (68) and remove cover (65). Check battery compartment for damaged or missing batteries.  b. Check for damaged or missing filler caps (66).	a. One or more batteries are damaged or missing.  b. One or more filler caps are damaged or missing.					

Table 2-1. Preventive Maintenance Checks and Services (PMCS) for M915 Family of Vehicles (Con't).

Item No.	Interval	Location	Procedure	Not Fully Mission Capable If:
		Item To Check/Service		
50 (Con't)	Weekly	Batteries	<p>c. Check for missing, broken, split, or frayed cables (69).</p> <p>d. Check for damaged terminal posts (67).</p> <p>e. Check for rust and corrosion.</p> <p>f. Check for cleanliness.</p> <p>g. Report any problems to Unit Maintenance.</p>	<p>c. Cables are missing, broken, split, or frayed.</p> <p>d. Terminal posts are damaged.</p>

The diagram shows an exploded view of a battery compartment. At the top is a rectangular cover (65) with a latch on the right side. Below it is a battery tray (66) containing several batteries. A terminal post (67) is shown protruding from the tray. A cable (69) is connected to this terminal post. The bottom of the compartment has a latch (68) on the right side.

Table 2-1. Preventive Maintenance Checks and Services (PMCS)  
for M915 Family of Vehicles (Con?).

Item	Interval	Location	Procedure	Not Fully Mission Capable If:
		Item To Check/Service		
51	Weekly	Spare Wheel and Tire	<p style="text-align: center;"><b>WARNING</b></p> <p>Operating truck with an underinflated or defective tire may lead to tire failure and loss of steering control. Damage to equipment or injury to personnel may result.</p> <p>a. Check pressure in tire and adjust as required:</p> <p>M915A2 - 105 psi (724 kPa) M916A1/M916A2 - 115 psi (793 kPa) M917A1/M917A1 w/MCS - 90 psi (621 kPa)</p> <p>b. Check wheel for cracks, breaks, or bends.</p>	
52	Weekly	Forward-Rear and Rear-Rear Wheels and Tires	<p style="text-align: center;"><b>WARNING</b></p> <p>Operating truck with an underinflated or defective tire may lead to tire failure and loss of steering control. Damage to equipment or injury to personnel may result.</p> <p style="text-align: center;"><b>NOTE</b></p> <p>M917A1 and M917A1 w/MCS CTIS must be in highway (HWY) mode for this check.</p> <p>a. Check pressure in tires and adjust as required:</p>	b. Wheel is cracked broken, or bent.

Table 2-1. Preventive Maintenance Checks and Services (PMCS)  
for M915 Family of Vehicles (Con't).

Item No.	Interval	Location	Procedure	Not Fully Mission Capable If:
		Item To Check/Service		
52 (Con't)	Weekly	Forward-Rear and Rear-Rear Wheels and Tires	<p>M915A2 (Empty) - 80 psi (552 kPa)                      M915A2 (Loaded) - 100 psi (690 kPa)                      M916A1/M916A2 (Empty) - 90 psi (621 kPa)                      M916A1/M916A2 (Loaded) - 90 psi (621 kPa)                      M917A1/M917A1 w/MCS - 90 psi (621 kPa)</p> <p>b. Ensure all wheel stud lug nuts are tight using wheel stud lug nut wrench and handle.                      c. Check wheel for cracks, breaks, or bends.</p>	<p>b. Any wheel stud is missing or lug nut is loose.                      c. Wheel is cracked broken, or bent.</p>

Table 2-1. Preventive Maintenance Checks and Services (PMCS)  
for M915 Family of Vehicles (Con't).

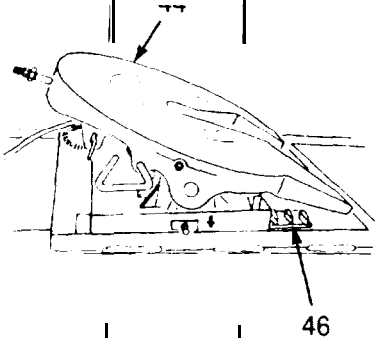
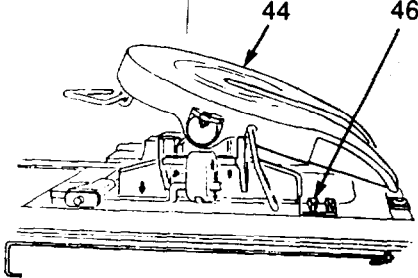
Item No.	Interval	Location	Procedure	Not Fully Mission Capable If:
		Item To Check/Service		
53	Weekly	Fifth Wheel (All Except M917A1 and M917A1 w/MCS)	<div style="text-align: center; border: 1px solid black; padding: 5px; width: fit-content; margin: 0 auto;"> <b>WARNING</b> </div> <p>Failure to keep fifth wheel plate lubricated could cause erratic steering due to binding of plate between tractor and trailer. This could result in an accident, causing injury to personnel.</p> <p>Coat fifth wheel plate (44) and sliding rails (46) liberally with grease. Lubricate at all grease fittings (Appendix F).</p> <div style="display: flex; justify-content: space-around; align-items: center;">   </div>	
54	Weekly	<div style="border: 1px solid black; padding: 2px; text-align: center; width: fit-content; margin: 0 auto;"> <b>UNDER VEHICLE</b> </div> <b>Steering Components</b>	Check front axle steering components for cracks, breaks, loose connections, or other damage.	Any steering component is cracked, broken, or loose,



Table 2-1. Preventive Maintenance Checks and Services (PMCS)  
for M915 Family of Vehicles (Con't).

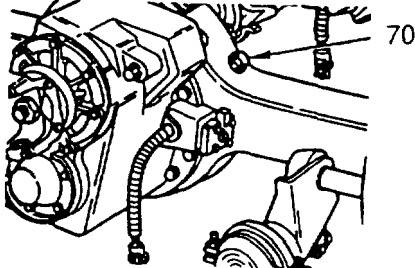
Item No.	Interval	Location	Procedure	Not Fully Mission Capable If:
		Item To Check/Service		
55	Weekly	Axle Breathers	<div style="text-align: center; border: 1px solid black; padding: 5px; width: fit-content; margin: 0 auto;">WARNING</div> <p>Dry cleaning solvent, P-D-680, is toxic and flammable. Always wear protective goggles and gloves, and use only in a well-ventilated area. Avoid contact with skin, eyes, and clothes, and DO NOT breathe vapors. DO NOT use near open flame or excessive heat. The solvent's flash point is 100°F-138°F (38°C-59°C). if you become dizzy while using cleaning solvent, immediately get fresh air and medical help. if solvent contacts eyes, immediately wash your eyes and get medical aid.</p> <p style="text-align: center;"><b>NOTE</b></p> <p>Perform the following service at all axles except the M915A2 front axle.</p> <div style="border: 1px solid black; padding: 5px; margin: 10px 0;">                     Without removing breather vent (70), check for a clogged vent. Clean with dry cleaning solvent (Item 17, Appendix D) as required to remove dirt and grease.                 </div> <div style="text-align: center; margin-top: 10px;">  </div>	

Table 2-1. Preventive Maintenance Checks and Services (PMCS)  
for M915 Family of Vehicles (Con?).

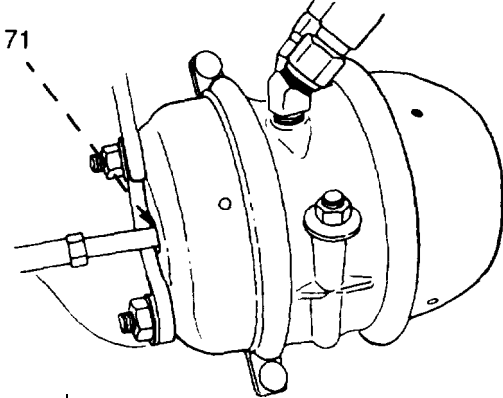
Item No.	Interval	Location	Procedure	Not Fully Mission Capable If:
		Item To Check/Service		
56	Weekly	Brake Chambers (All Except M915A2 and M916A1)	<p><b>NOTE</b></p> <p>Perform the following check at all axles.</p> <p>Check brake chamber service pushrod for showing of stroke alert indicator (71).</p>	Stroke alert indicate is visible.
				
57	Weekly	REAR AND RIGHT SIDE	<p>Check pintle hook (73) for looseness, damaged locking mechanism, and presence of cotter pin. Lubricate at all four grease fittings (72) (Appendix F), if pintle hook does not rotate freely by hand.</p>	
		Pintle Hook		

Table 2-1. Preventive Maintenance Checks and Services (PMCS) for M915 Family of Vehicles (Con't).

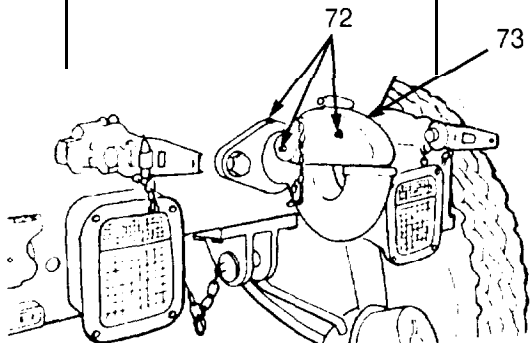
Item No.	Interval	Location	Procedure	Not Fully Mission Capable If:
		Item To Check/Service		
57 (Con't)	Weekly	Pintle Hook		
58	Weekly	Rear-Rear and Forward-Rear Wheels and Tires	<div style="border: 1px solid black; padding: 5px; text-align: center; margin: 10px auto; width: fit-content;"><b>WARNING</b></div> <p>Operating truck with an underinflated or defective tire may lead to tire failure and loss of steering control. Damage to equipment or injury to personnel may result.</p> <p style="text-align: center;"><b>NOTE</b></p> <p>M917A1 and M917A1 w/MCS CTIS must be in highway (HWY) mode for this check.</p> <p>a. Check pressure in tires and adjust as required:</p>	

Table 2-1. Preventive Maintenance Checks and Services (PMCS)  
for M915 Family of Vehicles (Con't).

Item No.	Interval	Location	Procedure	Not Fully Mission Capable If:
		Item To Check/Service		
58 (Con't)	Weekly	Rear-Rear and Forward-Rear Wheels and Tires	<p>M915A2 (Empty) - 80 psi (552 kPa)                      M915A2 (Loaded) - 100 psi (690 kPa)                      M916A1/M916A2 (Empty) - 90 psi (621 kPa)                      M916A1/M916A2 (Loaded) - 90 psi (621 kPa)                      M917A1/M917A1 w/MCS - 90 psi (621 kPa)</p> <p>b. Ensure all wheel stud lug nuts are tight using wheel stud lug nut wrench and handle</p> <p>c. Check wheel for cracks, breaks, or bends.</p>	<p>b. Any wheel stud is missing or lug nut is loose</p> <p>c. Wheel is cracked broken, or bent.</p>
		59	Weekly	Front Wheel and Tire

Table 2-1. Preventive Maintenance Checks and Services (PMCS)  
for M915 Family of Vehicles (Con't).

Item No.	Interval	Location	Procedure	Not Fully Mission Capable If:
		Item To Check/Service		
59 (Con't)	Weekly	Front Wheel and Tire	<p>a. Check pressure in tires and adjust as required:</p> <p>M915A2 (Empty) - 80 psi (552 kPa)                      M915A2 (Loaded) - 100 psi (690 kPa)                      M916A1/M916A2 (Empty) - 90 psi (621 kPa)                      M916A1/M916A2 (Loaded) - 90 psi (621 kPa)                      M917A1/M917A1 w/MCS - 90 psi (621 kPa)</p> <p>b. Ensure all wheel stud lug nuts are tight using wheel stud lug nut wrench and handle</p> <p>c. Check wheel for cracks, breaks, or bends.</p>	<p>b. Any wheel stud is missing or lug nut is loose</p> <p>c. Wheel is cracked, broken, or bent.</p>
		CAB INTERIOR		
60	Weekly	Doors and Windows	Check operation and general condition of cab doors and windows.	

Table 2-1. Preventive Maintenance Checks and Services (PMCS) for M915 Family of Vehicles (Con't).

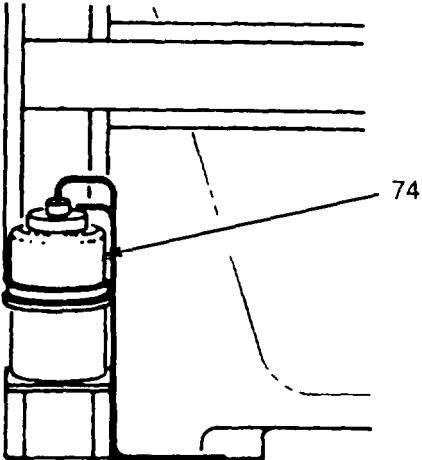
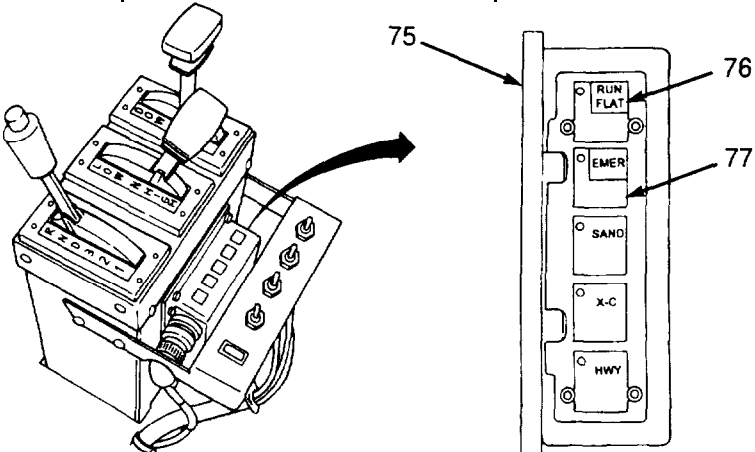
Item No.	Interval	Location	Procedure	Not Fully Mission Capable if:
		Item To Check/Service		
61	Weekly	Windshield Washer Reservoir	<p>Check level of fluid in reservoir (74) located behind driver's seat. Add windshield washer cleaning compound (Item 3, Appendix D) as required.</p> 	
62	Weekly	CTIS	<p>a. With engine running, select RUN FLAT key (76). Check system for air leaks.</p> <p>b. With engine running, select one inflate and one deflate mode on selector panel (75). Check that tires inflate and deflate.</p> <p>c. While driving, select EMER mode key (77) and check that instrument panel reduce MPH indicator light comes on.</p>	<p>b. Mission requires use of CTIS and CTIS is malfunctioning.</p>

Table 2-1. Preventive Maintenance Checks and Services (PMCS) for M915 Family of Vehicles (Con't).

Item No.	Interval	Location	Procedure	Not Fully Mission Capable if:
		Item To Check/Service		
62 (Con't)	Weekly	CTIS		
63	Monthly	OVER-ALL VEHICLE		
		Under-carriage, Frame, Cab, and Propeller Shafts	<p>a. Check for obvious damage to frame and undercarriage.</p> <p>b. Check propeller shafts and U-joints for loose or broken bolts and nuts.</p>	<p>a. Any loose or broken frame side rails, crossmembers, broken welds, or broken bolts are found.</p> <p>b. Mounting bolts and nuts are loose or missing.</p>
		Air System	Check all air lines, fittings, and valves for looseness or damage.	Any air lines, fittings, or valves are loose or damaged.
64	Monthly	Air System	Check all air lines, fittings, and valves for looseness or damage.	Any air lines, fittings, or valves are loose or damaged.
65	Monthly	Exhaust System	Check exhaust system for corrosion, looseness, or damage.	Any exhaust leak are suspected.

**Table 2-1. Preventive Maintenance Checks and Services (PMCS)  
for M915 Family of Vehicles (Con't).**

Item No.	Interval	Location	Procedure	Not Fully Mission Capable if:
		item To Check/Service		
66	Monthly	Hydraulic System (M916A1 and M916A2)	Check winch reservoir, drum, hydraulic controls, lines, and fittings for looseness, leaks, or signs of other damage.	Any hydraulic components are loose, leaking, or damaged.
67	Monthly	Spare Wheel and Tire and Vehicle Tires	<ul style="list-style-type: none"> <li>a. Check spare wheel and tire for cuts, gouges, cracks, or uneven wear.</li> <li>b. Check for secure mounting of spare wheel and tire.</li> <li>c. Check all vehicle tires for cuts, gouges, cracks, or uneven wear.</li> </ul>	<ul style="list-style-type: none"> <li>a. Spare tire is missing or damaged.</li> <li>c. Any tire is missing or damaged.</li> </ul>
68	Monthly	Radiator (All Models) and Condenser (All Except M915A2 and M916A1)	Remove dirt and debris from cooling fins.	
69	Monthly	Air Conditioner (All Except M915A2 and M916A1)	Check air conditioner operation. Operate for at least five minutes to help prevent drying and cracking of tubing seals and reduce refrigerant leaks in the system.	



### Section III. OPERATION UNDER USUAL CONDITIONS

Paragraph Number	Paragraph Number	Page Number
2-12.	General . . . . .	2-82
2-13.	Initial Adjustments, Daily Checks, and Self-Tests . . . . .	2-82
2-14.	Start Engine . . . . .	2-85
2-15.	Operate Transmission . . . . .	2-87
2-16.	Operate Transfer Case (All Except M915A2) . . . . .	2-88
2-17.	Operate CTIS (M917A1 and M917A1 w/MCS) . . . . .	2-89
2-18.	Driving Tips . . . . .	2-93
2-19.	Driving . . . . .	2-96
2-20.	Shut Down Engine . . . . .	2-97.0
2-21.	Operate Sliding Fifth Wheel (M915A2) . . . . .	2-98
2-22.	Operate Sliding Fifth Wheel (M916A1 and M916A2). . . . .	2-100
2-23.	Couple to Truck (All Except M917A1 and M917A1 w/MCS) . . . . .	2-102
2-24.	Uncouple from Truck (All Except M917A1 and M917A1 w/MCS) . . . . .	2-105
2-25.	Pintle Towing Procedures . . . . .	2-107
2-26.	Mud Flap Stowage (All Except M917A1 and M917A1w/MCS) . . . . .	2-108
2-27.	Operate Power Take-Off (PTO) (All Except M915A2) . . . . .	2-109
2-28.	Operate Winch (M916A1 and M916A2). . . . .	2-110
2-29.	Operate Air Conditioner (All Except M915A2 and M916A1) . . . . .	2-113
2-30.	Operate Portable Fire Extinguisher . . . . .	2-114
2-31.	Operate Lights . . . . .	2-116
2-32.	Rifle Mounting Kit. . . . .	2-117
2-33.	Operate Heater and Defroster . . . . .	2-117
2-34.	Preparation for Movement . . . . .	2-118

---

## 2-12. GENERAL.

---

**WARNING**

These vehicles have been designed to operate safely and efficiently within the limits specified in this TM. Operation beyond these limits is prohibited in accordance with AR 70-1 without written approval from: Commander, U.S. Army Tank-automotive and Armaments Command, ATTN:AMSTA-DSA-CS, Warren, MI 48397-5000.

**NOTE**

For operation of the M917A1 and M917A1 w/MCS dump truck body, refer to TM 5-3805-264-14&P.

This section contains instructions for safely operating the M915 Family of Vehicles under usual conditions. Unusual conditions are defined and described in Section IV of this chapter.

---

## 2-13. INITIAL ADJUSTMENTS, DAILY CHECKS, AND SELF-TESTS.

---

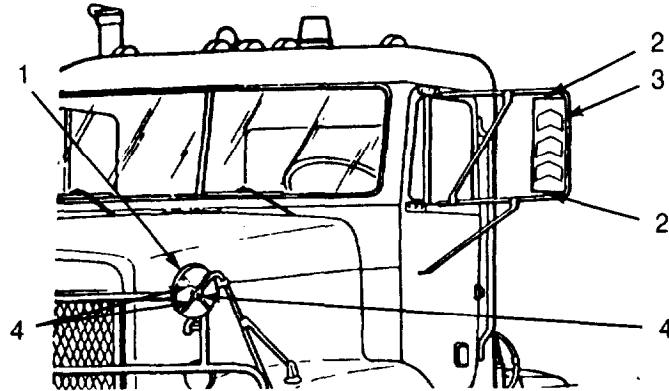
- a. Perform *Before* operation Preventive Maintenance Checks and Services (PMCS) (Chapter 2, Section II).
- b. Change military load classification (paragraph 1-12), if necessary.
- c. Adjust side mirrors (3) by loosening two nuts (2) and moving side mirror to proper position. Tighten two nuts.

**CAUTION**

**DO NOT attempt to adjust spotter mirrors without loosening screws. Attaching screw may become loose and result in loss of spotter mirror.**

- d. Adjust spotter mirrors (1) by loosening three screws (4) and moving spotter mirror to proper position. Tighten three screws.

**2-13. INITIAL ADJUSTMENTS, DAILY CHECKS, AND SELF-TESTS (Con't).**



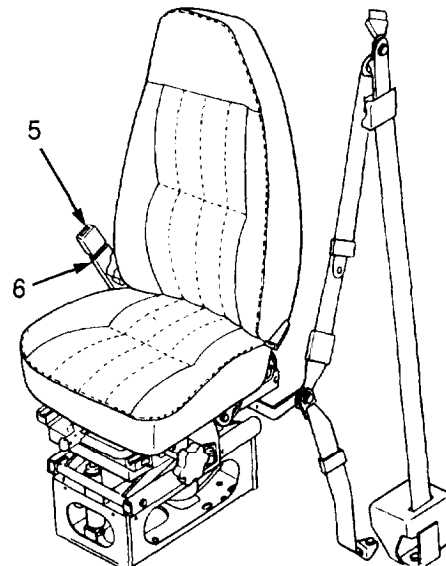
**WARNING**

**Use of seat belts while operating vehicle is mandatory. Fasten belt BEFORE driving. Trying to fasten three-point seat belt while driving creates a hazardous condition. Failure to follow this warning may result in death or injury to personnel.**

e. Adjust tether belt.

(1) Loosen tether belt (6) and turn buckle (5) at a right angle to webbing. Pull buckle away from inner webbing.

(2) Tighten tether belt (6) to proper tension. Ensure that movement of seat suspension is not restricted.



---

## 2-13. INITIAL ADJUSTMENTS, DAILY CHECKS, AND SELF-TESTS (Con't).

---

f. Fasten seat belt.

(1) Slowly pull link (9) out of retractor (10) and across lap far enough to engage buckle (5). If retractor locks too soon, allow belt to retract slightly and then pull slowly.

(2) Push link (9) into buckle (5).

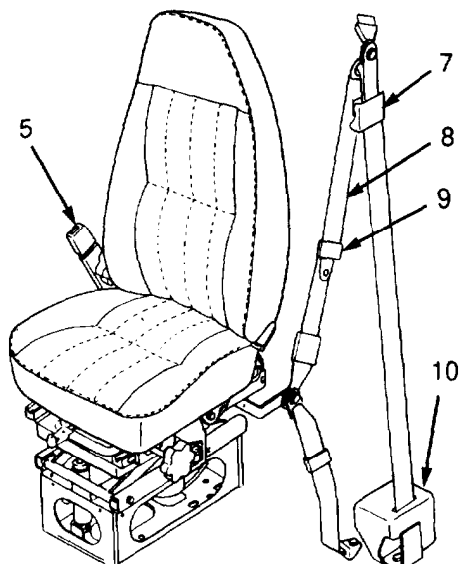
(3) Position shoulder strap (8) diagonally across chest.

### NOTE

- if engaging **Komfort Loc®**, allow no more than 1 in. (2.5 cm) between chest and shoulder strap.
- **Komfort Loc®** will automatically release if pressure is applied to shoulder strap.

(4) If desired, engage **Komfort Loc®** (7) by pulling on shoulder strap (8) and pressing **Komfort Loc®** lever up.

(5) To release seat belt, press release button on buckle (5). if **Komfort Loc®** (7) was engaged, give shoulder strap (8) a quick downward tug to release.



---

**2-14. START ENGINE.**

---

- a. Ensure that parking brake is applied (paragraph 2-2).

**NOTE**

**The M915 Family of Vehicles are equipped with a neutral safety switch which prevents the engine from being started if transmission is not in Neutral (N).**

- b. Place transmission selector lever in Neutral (N).
- c. Ensure that all accessories are off and engine brake system switches are in OFF position.

**WARNING**

**Check Engine button is used for diagnostic purposes only. DO NOT push Check Engine button during vehicle operation because engine will slow down to an idle, which could cause hazardous operating condition. Return to operating mode by releasing accelerator pedal and allowing engine to return to idle speed. Failure to follow this warning may result in injury to personnel.**

d. Turn ignition switch to ON position. CHK ENG light and SHUT DOWN light come on and then turn off after approximately five seconds. Engine oil warning light, low air pressure warning light, TRACTOR ABS light, PARK BRAKE light (if applied), and warning buzzer come on. For M917A1 and M917A1 w/MCS, CTIS selector panel illuminates and should display a single solid mode light or a single flashing mode light.

e. For M915A2, ensure that interaxle lockout control valve lever is in UNLOCK position.

f. For all models except M915A2, ensure that all-wheel drive control valve lever is in DISENGAGE position and power take-off (PTO) switch is in OFF position.

**CAUTION**

**DO NOT operate starter motor for more than 30 seconds at a time. After 30 seconds, allow starter motor to cool for at least two minutes before attempting to start engine again. Excessive heating of starter motor may result in damage or early starter failure.**

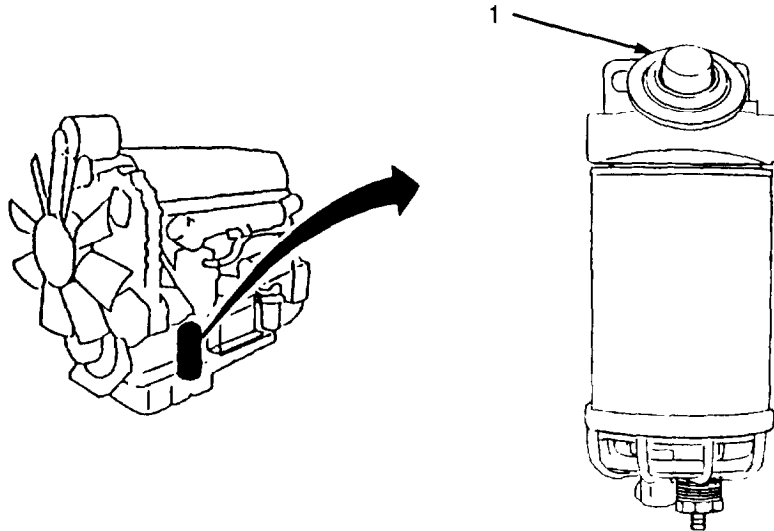
- g. Press engine start button.

---

## 2-14. START ENGINE (Con't).

---

h. When engine starts, release engine start button. If engine fails to start, prime fuel system by pumping fuel/water separator valve (1) for one minute, Press engine start button. If engine still fails to start, pump valve for 20 seconds. Press engine start button. if engine still fails to start, notify Unit Maintenance.



**CAUTION**

**DO NOT run engine above idle speed until oil pressure gage indicates at least 12 psi (83 kPa) at idle speed.**

i. Monitor gages and indicators. If after ten seconds there is no indication of oil pressure and SHUT DOWN light, engine oil warning light, or CHK ENG light remains on, shut down engine (paragraph 2-20) and perform troubleshooting (Chapter 3, Section II).

**NOTE**

- Perform steps j through m if outside temperature is at or below 32°F (0°C).
  - Vehicles not equipped with a manual ether quick-start system are equipped with an automatic ether injection system for cold weather starting.
- j. Perform steps a through h.

---

## 2-14. START ENGINE (Con't).

---

**CAUTION**

- For vehicles equipped with manual ether quick-start system, never press ether quick-start button unless cranking engine simultaneously. Buildup of ether fumes may result in combustion in intake manifold.
- DO NOT operate starter motor for more than 30 seconds at a time. After 30 seconds, allow starter motor to cool for at least two minutes before attempting to start engine again. Excessive heating of starter motor may result in damage or early starter failure.
- k. For manual ether quick-start system, press engine start button and at the same time press ether quick-start button once.
- l. When engine starts, release engine start button.

**CAUTION**

**DO NOT run engine above idle speed until oil pressure gage indicates at least 12 psi (83 kPa) at idle speed.**

- m. Do not run engine above 600 rpm until normal oil pressure is indicated on engine oil pressure gage.

---

## 2-15. OPERATE TRANSMISSION.

---

- a. **General.** The transmission may be placed in six different gears.
  - (1) **Reverse (R).** Reverse (R) is used to back up the vehicle. Vehicle must be brought to a complete stop before shifting from a forward gear to reverse gear or visa versa.

---

## 2-15. OPERATE TRANSMISSION (Con't).

---

**CAUTION**

**Do not allow truck to coast in Neutral (N). This can result in severe transmission damage and engine braking is not available.**

(2) **Neutral (N).** Neutral (N) is normal transmission position when vehicle is not in use. Use this gear to start engine.

(3) **Drive (D).** When placed in Drive (D), the transmission starts out in 1st gear and automatically progresses to 4th gear. During slowdown, transmission automatically downshifts.

(4) **Gears 2 and 3.** Use 2nd or 3rd gears when road, load, or traffic conditions make it preferable to use lower gears. When conditions improve, return to Drive (D).

(5) **Gear 1.** 1st gear is the low gear used for pulling through mud, snow, or going up steep grades. This position also offers maximum engine braking power.

b. **Operation.**

- (1) Depress brake pedal and hold.
- (2) Release parking brake (paragraph 2-2).
- (3) Move transmission selector lever to desired gear.

---

## 2-16. OPERATE TRANSFER CASE (ALL EXCEPT M915A2).

---

a. **General.** Vehicle must be stopped completely and transmission must be in Neutral (N) position before transfer case can be shifted into position.

(1) **High.** High is the normal operating position.

(2) **Neutral (N).** Neutral (N) is the normal position when vehicle is not in use. Vehicle will not move if transfer case is in Neutral (N).

(3) **Low.** Low engages all-wheel drive which is normally used when transmission gear selection is other than Drive (D).

b. **Operation.**

- (1) Stop vehicle and place transmission in Neutral (N) position.



---

**2-16. OPERATE TRANSFER CASE (ALL EXCEPT M915A2)  
(Con't).**

---

**CAUTION**

Ensure that transfer case selector lever is fully engaged.  
Failure to follow this caution may result in equipment damage.

**NOTE**

An air leak may be heard if transfer case selector lever is not fully engaged.

- (2) Move transfer case selector lever to desired position.

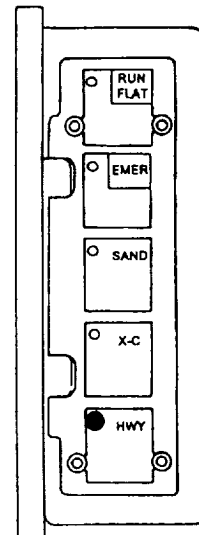
---

**2-17. OPERATE CTIS (M917A1 AND M917A1 W/MCS).**

---

a. **CTIS Selector Panel Display Summary.**

(1) **Single Mode Light.** A solid single mode light indicates pressure has been achieved for that mode, CTIS is inactive, and wheel valves are closed. A flashing single mode light indicates CTIS is working to achieve pressure associated with that mode.

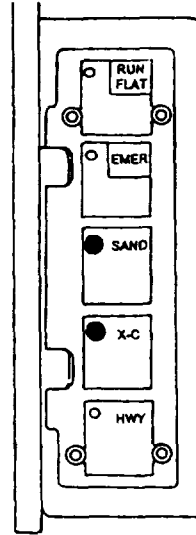


---

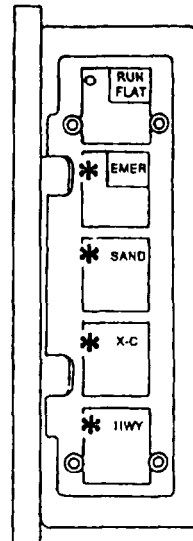
**2-17. OPERATE CTIS (M917A1 AND M917A1 W/MCS) (Con't).**

---

(2) **Two Mode Lights on Solid.** CTIS has shut off with tire pressure between two mode settings, perform troubleshooting (Chapter 3, Section II).

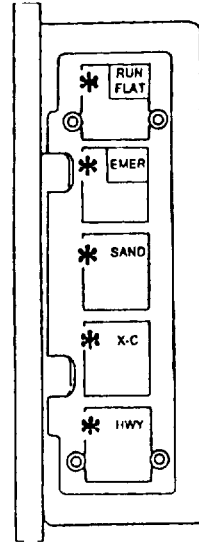


(3) **Four Mode Lights Flashing.** CTIS has shut off and is waiting for operator instruction, perform troubleshooting (Chapter 3, Section II).

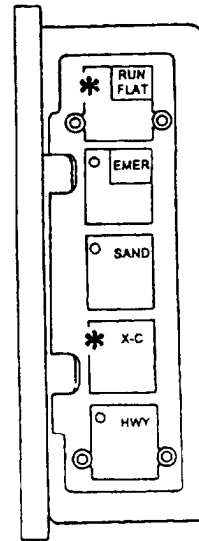


**2-17. OPERATE CTIS (M917A1 AND M917A1 W/MCS) (Con't).**

(4) **Five Mode Lights Flashing.** CTIS has shut off due to fault detection of a CTIS component, perform troubleshooting (Chapter 3, Section II).



(5) **RUN FLAT Flashing (with a mode light).** RUN FLAT is selected. Tire pressures are checked at more frequent intervals.



(6) **No Mode Lights.** Inadequate vehicle power, perform troubleshooting (Chapter 3, Section II).

(7) **Lights Sequentially Flashing.** Configuration error, perform troubleshooting (Chapter 3, Section II).

---

## 2-17. OPERATE CTIS (M917A1 AND M917A1 W/KS) (Con't).

---

### b. CTIS Operation.

#### NOTE

**Before operating CTIS, become familiar with CTIS principles of operation (Chapter 1, Section III) and CTIS controls and indicators (Chapter 2, Section I).**

(1) When engine is started, tire pressures are pressures LAST ACHIEVED when vehicle was operated (i.e., cross-country pressures achieved, HWY selected and pressures not achieved, vehicle shut down). Upon restart, system will default to cross-country.

(2) Tire pressures may be checked at any time by pressing mode key for selected mode. CTIS automatically performs inflation or deflation as required.

(3) Press HWY (Highway) mode key to operate on improved road surfaces. Do not exceed 60 mph (97 kph) or reduce MPH indicator light will come on. Vehicle speed should be reduced at this time.

(4) Press X-C (Cross-Country) mode key to operate on non-paved secondary roads and unimproved surfaces. Do not exceed 40 mph (64 kph) or reduce MPH indicator light will come on. Vehicle speed should be reduced at this time. If overspeed is exceeded for more than one minute, CTIS will automatically inflate to highway setting.

(5) Press SAND mode key to operate in sand, snow, and mud. Do not exceed 25 mph (40 kph) or reduce MPH indicator light will come on. Vehicle speed should be reduced at this time. If overspeed is exceeded for more than one minute, CTIS will automatically inflate to cross-country setting.

<b>WARNING</b>
----------------

**When resuming operation on highway surfaces, be sure to reset CTIS selector panel to higher tire pressures. Operating vehicle with underinflated tires will cause premature tire wear or damage to tires causing unsafe driving conditions. Failure to follow this warning may result in death or injury to personnel.**

(6) Reset CTIS to higher tire pressures as required.

---

## 2-18. DRIVING TIPS.

---

**WARNING**

**BE ALERT for personnel in area while operating truck. Always check to ensure area is clear of personnel and obstructions before moving out. Failure to follow this warning may result in serious injury or death to personnel.**

**CAUTION**

**Governed speed is 2100 rpm. If engine is allowed to exceed governed speed, serious engine or transmission damage may result.**

- a. Check gages and indicators frequently. If gage or indicator shows an abnormal reading or warning light comes on, bring vehicle to a safe stop, shut down engine (paragraph 2-20), and investigate cause.

**CAUTION**

**Steering wheel should not be held at full steer for more than 10 seconds. This could result in overheating of oil, loss of oil from power steering reservoir, and pump gear damage.**

- b. Avoid over steering. Become familiar with steering characteristics of vehicle before attempting maneuvers in limited space.

- c. Drive efficiently and economically.

- (1) **Driving at Highway Speed.** Recommended normal highway cruising range is 1800 - 1900 rpm. If operating on hilly terrain, in high winds, or in other conditions that make it impractical to operate without reserve power, operate vehicle in lower gear.

- (2) **Driving in City.** When slowing for posted speed zones, remain in Drive (D) position and reduce engine rpm.

- (3) **Driving Uphill (under load).** Proper use of gears shortens time on hills and minimize amount of shifting. As vehicle starts uphill, press accelerator pedal as required to maintain speed.

---

## 2-18. DRIVING TIPS (Con't).

---

**WARNING**

**DO NOT use engine brake if road surfaces are slippery. Use of engine brake on wet, icy, or snow-covered roads could result in loss of vehicle control. Failure to follow this warning could result in death or injury to personnel or damage to equipment.**

(4) **Use Engine as a Braking Force.** The vehicle is equipped with an engine braking system that enables the engine to act as a brake. The engine brake should be used for descending grades and is most effective between 1750-2100 rpm.

(a) If maximum engine braking is required, turn both engine brake selection switches up to engage six cylinders.

(b) If less than maximum engine braking is required, turn left engine brake selection switch up and right engine brake selection switch down to engage two cylinders, or left engine brake selection switch down and right engine brake selection switch up to engage four cylinders.

(5) **Downhill Braking.**

(a) Select a gear that allows engine, with engine brake applied, to control vehicle speed with engine rpm at or below 2100 rpm without applying service brakes. As downgrade is approached, progressively select a gear that, when combined with engine brake, will allow you to maintain engine speed of 1750-2100 rpm.

(b) As engine speed exceeds 2100 rpm, use one positive application of service brakes to slow engine speed to 1650 rpm, release engine brake, downshift one gear, and apply engine brake. Repeat this procedure until engine speed can be maintained at 1750 - 2100 rpm.

**CAUTION**

**Excessive use of service brake to control downhill speed will result in loss of braking power due to heat build-up.**

(c) If you experience a total loss of braking due to heat build-up, apply engine brake (six cylinders), upshift as engine speed approaches 2100 rpm, and in Drive (D) position continue to apply engine brake and maintain directional control of vehicle.

---

**2-18. DRIVING TIPS (Con't).**

---

(d) The anti-lock brake system (ABS) will help in controlling wheel lockup and tire skidding during an emergency.

- d. On M915A2, engage interaxle lockout as required.

**CAUTION**

**DO NOT actuate interaxle lockout control valve while tires are slipping. DO NOT operate vehicle continuously with interaxle lockout control valve locked during extended good road conditions. Damage to axle gearing and excessive tire wear could result.**

**NOTE**

**ABS warning light blinks when interaxle lockout is engaged.**

(1) To lock interaxle, ease up on accelerator pedal momentarily and move interaxle lockout control valve lever to LOCK position while maintaining vehicle speed. Axle lock indicator light comes on. Proceed over poor road conditions with caution. Do not wait until traction is lost and tires are spinning before locking interaxle.

(2) To unlock interaxle, place interaxle lockout control valve lever in UNLOCK position and remove foot from accelerator. Observe that axle lock indicator light goes off. System is now unlocked.

- e. For all except M915A2, engage all-wheel drive as required.

**CAUTION**

**DO NOT actuate all-wheel drive control valve while vehicle is in motion. Do not operate vehicle continuously with all-wheel drive control valve engaged during extended good road conditions. Damage to axle gearing and excessive tire wear could result.**

**NOTE**

**All-wheel drive may be engaged in two ways. Perform either step (1) or step (2) to engage.**

(1) With vehicle stopped and transfer case selector in HIGH range, place all-wheel drive control valve lever to ENGAGE position. Axle lock indicator light will come on and all-wheel drive is now engaged.

---

## 2-18. DRIVING TIPS (Con't).

---

(2) With vehicle stopped, shift transfer case selector into LOW range. Axle lock indicator light will come on and all-wheel drive is now engaged.

### NOTE

- **All-wheel drive may be disengaged in two ways. Perform either step (3) or step (4) to disengage.**
- **DO NOT operate vehicle if axle lock indicator light stays on. Notify Unit Maintenance.**

(3) To disengage all-wheel drive when transfer case selector is in LOW range, stop vehicle and move transfer case selector to HIGH range. All-wheel drive is disengaged and axle lock indicator light will go off.

(4) To disengage all-wheel drive when transfer case selector is in HIGH range and all-wheel drive control valve lever is in ENGAGE position, move all-wheel drive control valve lever to DISENGAGE position and remove foot from accelerator.

---

## 2-19. DRIVING.

---

- a. Perform initial adjustments, daily checks, and self-tests (paragraph 2-13).
- b. Start engine (paragraph 2-14) and allow truck to warm up.

<b>WARNING</b>
----------------

**Serious injury may result if head clearance is not adequate while sitting in seat. Before driving or riding in vehicle, ensure there is adequate clearance at maximum upward travel of seat.**

- c. Adjust seat (paragraph 2-5).
- d. Adjust seat belt (paragraph 2-13).
- e. Turn on lights, as necessary (paragraph 2-2).
- f. Select transmission gear (paragraph 2-15).
- g. Select transfer case position (paragraph (2-16).
- h. For M917A1 and M917A1 w/MCS, select CTIS setting (paragraph 2-17).



---

**2-19. DRIVING (Con't).**

---

- i. Move truck gradually by depressing accelerator.
- j. Ensure ABS indicator light goes off after 4 mph (6 kph) is exceeded (paragraph 2-2).

**NOTE**

**During long engine idling periods, engine coolant temperature will fall below normal operating range. The incomplete combustion of fuel in a cold engine will cause crankcase dilution, formation of lacquer or gummy deposits on valves, pistons, and rings, and rapid accumulation of engine sludge.**

- k. Avoid unnecessary engine idling.

**CAUTION**

**Care must be exercised if tractor or trailer ABS light comes on while driving, possibly indicating an ABS malfunction. Although the regular/normal vehicle system is still fully operational, you should continue in a safe manner and reduce speed to 40 mph (64 kph), until the mission is complete. When the mission is complete, report to Unit Maintenance to clear the ABS fault and restore full ABS capabilities.**

**NOTE**

**If, during operation, Shut Down, Check Engine, Engine Temperature, Engine Oil, or Low Air Pressure warning lights come on, stop vehicle, shut down engine, and investigate cause.**

- l. Check gages and indicators frequently.
- m. Operate engine brakes as required (paragraph 2-2).
- n. Operate interaxle lockout/all-wheel drive, as required (paragraph 2-18). ABS warning light blinks when interaxle lockout/all-wheel drive is engaged.
- o. Stop vehicle by applying long even pressure to service brakes. Do not pump brakes.
- p. After vehicle is at a complete stop, place transmission in Neutral (N), transfer case in Neutral (N), and pull parking brake control knob OUT.

---

**2-20. SHUT DOWN ENGINE.**

---

**CAUTION**

**Shutting down engine without performing step a could damage turbocharger.**

- a. Run engine at idle for four to five minutes.
- b. Turn all accessories off (paragraph 2-2).
- c. Move ignition switch to OFF position.
- d. Perform *After* operation PMCS (Chapter 2, Section II).

THIS PAGE INTENTIONALLY LEFT BLANK

---

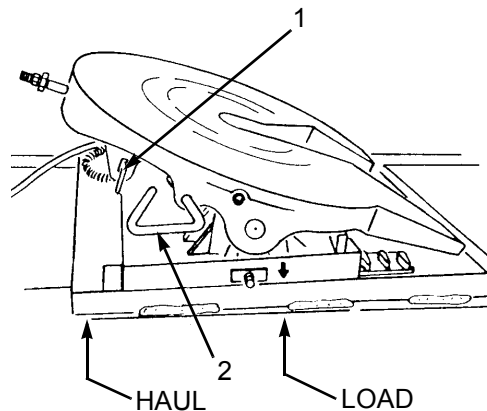
## 2-21. OPERATE SLIDING FIFTH WHEEL (M915A2).

---

**CAUTION**

- The M915A2 is designed to be used with M871, M872, and M1062 semitrailers only. Other semitrailers may cause equipment damage.
- Trailer must be blocked and trailer brakes locked to prevent damage to tractor or trailer by uncontrolled sliding of fifth wheel.
- If towing M872 trailer, rear mud flaps must be removed and stowed in brackets provided. Failure to do so will cause equipment damage.
- The tractor/trailer combination is not capable of turning more than a 90° angle.
- The M915A2, M916A1, and M916A2 truck tractors have the capability to turn greater than 90°. Care must be taken to avoid hitting semitrailer with tractor when turning more than 90°.
- Operator must use caution when cresting hills which cause the truck tractor to have a nose down angle greater than 4° with respect to towed semitrailer. Damage to vehicle or loss of control could occur.

a. Pull secondary lock release handle (1) before releasing primary lock release handle (2) to uncouple the trailer.



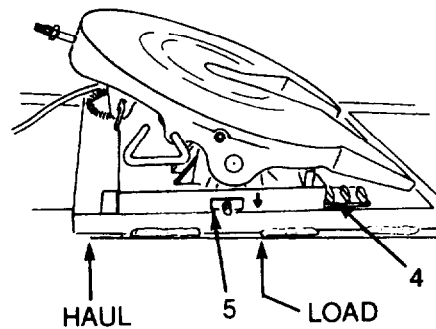
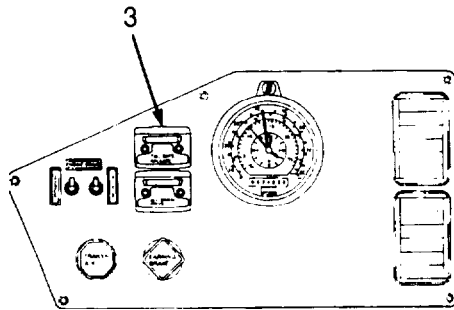
**2-21. OPERATE SLIDING FIFTH WHEEL (M915A2) (Con't).**

- b. Place fifth wheel slide control valve lever (3) in UNLOCK position to release two slide locking plungers (5). Ensure that plungers release. If plungers did not release, lower landing gear to relieve pressure and allow fifth wheel to slide more easily.
- c. Drive tractor slowly forward or backward to position fifth wheel.
- d. After sliding to desired position, engage two slide locking plungers (5) by placing fifth wheel slide control valve lever (3) in LOCK position.

**CAUTION**

**Do not operate vehicle if slide locking plungers are not fully engaged and landing gear is not fully retracted. This could result in damage to tractor, trailer, and landing gear.**

- e. Visually check that two slide locking plungers (5) are retracted and fully engaged. It may be necessary to leave trailer brakes locked and <sup>move tractor</sup> slightly to engage plungers in rack teeth (4).
- f. If lowered, raise landing gear to fully retracted position.



---

**2-22. OPERATE SLIDING FIFTH WHEEL (M916A1 AND M916A2).**

---

**WARNING**

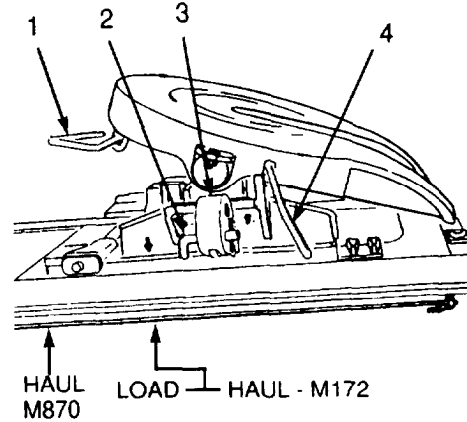
- **DO NOT tow 6,000 gallon water distributors with a partial load except when in use on construction sites and a maximum speed of 10 mph. When towing outside of construction sites, TRAILERS MUST BE EMPTY OR FULL. Either drain water distributor empty (preferred) or fill to capacity. MAXIMUM SPEEDS FOR BOTH TRAILERS ARE: HIGHWAY 55 MPH, GRAVEL/DIRT 30 MPH, OFF-ROAD 5 MPH. Failure to follow this warning could result in unsafe driving conditions causing serious injury or death to personnel and damage to equipment.**
- **When towing model WD6S 6,000 gallon water distributor, fifth wheel must be in rear setting (LOAD HAUL-M172). For model 60PRS, fifth wheel must be at rear setting (LOAD HAUL M172) to load and front setting (HAUL M870) to tow. For all models, travel lockout must be engaged to prevent side-to-side oscillation of water distributor. Failure to follow this warning could result in unsafe driving conditions causing serious injury or death to personnel and damage to equipment.**

**CAUTION**

- **The M916A1 and M916A2 is designed to be used with M870 and M172 semitrailers and models 60PRS and WD6S water distributors. Other semitrailers may cause equipment damage.**
- **Trailer must be blocked and trailer brakes locked to prevent damage to tractor or trailer by uncontrolled sliding fifth wheel.**
- **If towing M172 trailer, rear mud flaps must be removed and stowed. Failure to do so will cause equipment damage.**
  - a. Pull secondary lock release handle (1) before releasing the primary lock release handle (4).

**2-22. OPERATE SLIDING FIFTH WHEEL (M916A1 AND M916A2)  
(Con't).**

b. When operating off-road, release fifth wheel (oscillating) travel lockout by removing locking pin (2) lowering lockout (3) and reinserting locking pin, allowing fifth wheel to oscillate side-to-side.



**WARNING**

**Handle must be used when operating release lever. Failure to do so could result in injury to personnel.**

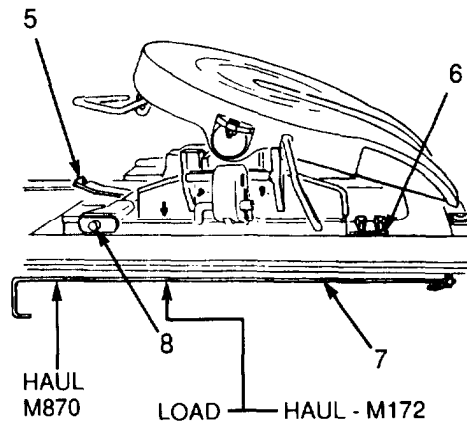
c. Using handle (7), pull locking release lever (5) and release two slide locking plungers (8). Ensure that plungers release. If plungers did not release, lower landing gear to relieve pressure and allow fifth wheel to slide more easily.

d. Drive tractor slowly forward or backward to position fifth wheel.

e. After sliding to desired position, engage two slide locking plungers (8) by using handle (7) to trip release lever (5) and allow plungers to retract.

f. Visually check that two slide locking plungers (8) are retracted and fully engaged. It may be necessary to leave trailer brakes locked and move tractor slightly to engage plungers in rack teeth (6).

g. If lowered, raise landing gear to fully retracted position.



---

**2-23. COUPLE TO TRUCK (ALL EXCEPT M917A1 AND M917A1 W/MCS).**

---

**WARNING**

- Do not use trailer handbrake as primary brake to keep tension on coupling system. This will cause undue tension on brakes and coupling which could result in injury to personnel or damage to equipment. Prevent problems with slack in fifth wheel by using good braking habits and adjusting coupling and braking systems properly.
  
- DO NOT tow 6,000 gallon water distributors with a partial load except when in use on construction sites and a maximum speed of 10 mph. When towing outside of construction sites, TRAILERS MUST BE EMPTY OR FULL. Either drain water distributor empty (preferred) or fill to capacity. MAXIMUM SPEEDS FOR BOTH TRAILERS ARE: HIGHWAY 55 MPH, GRAVEL/DIRT 30 MPH, OFF-ROAD 5 MPH. Failure to follow this warning could result in unsafe driving conditions causing serious injury or death to personnel and damage to equipment.
  
- When towing model WD6S 6,000 gallon water distributor, fifth wheel must be in rear setting (LOAD HAUL-M172). For model 60PRS, fifth wheel must be at rear setting (LOAD HAUL M172) to load and front setting (HAUL M870) to tow. For all models, travel lockout must be engaged to prevent side-to-side oscillation of water distributor. Failure to follow this warning could result in unsafe driving conditions causing serious injury or death to personnel and damage to equipment.

**CAUTION**

If towing M172 or M872 trailer, rear mud flaps must be removed and stowed. Failure to follow this caution may result in equipment damage.

- a. On M916A1 and M916A2, make sure secondary lock release handle is pulled OUT (paragraph 2-22).



---

**2-23. COUPLE TO TRUCK (ALL EXCEPT M917A1 AND M917A1 W/MCS) (Con't).**

---

- b. Ensure that fifth wheel ramps are level with, or are slightly below, the angle of the pickup ramps.

**WARNING**

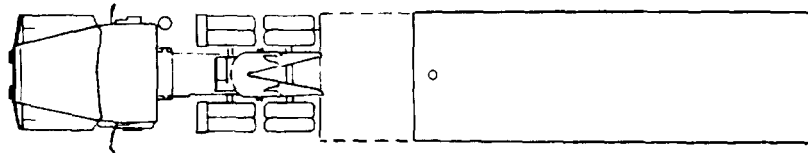
Use caution when coupling to truck. **BE ALERT** for personnel in area. Ensure that hands, arms, and body are clear of potential pinch points. Failure to follow this warning may result in injury to personnel.

**CAUTION**

Be careful not to run king pin up fifth wheel ramps as this can damage king pin and/or fifth wheel.

**NOTE**

- Truck and trailer must be aligned.
- Use a ground guide if one is available.



PROPER ALIGNMENT WITH  
SEMITRAILER

- c. Slowly back tractor under semitrailer king pin plate or gooseneck. Stop when king pin plate or gooseneck is touching guide ramps. Semitrailer king pin should be centered as closely as possible in throat of fifth wheel.

- d. Ensure that semitrailer is picked up with fifth wheel ramps. If king pin comes in too high, it will not engage in fifth wheel correctly. Adjust semitrailer if needed.

---

**2-23. COUPLE TO TRUCK (ALL EXCEPT M917A1 AND M917A1 W/MCS) (Con't).**

---

e. For M916A1 and M916A2, when coupling to M870 semitrailer, pay out winch cable (paragraph 2-28) and attach to gooseneck on trailer. Release vehicle parking brake to allow vehicle to be pulled back under trailer until king pin locks into fifth wheel. Disconnect and stow winch cable (paragraph 2-25).

**NOTE**

**One 12-volt light cable and one 24-volt light cable are stored in tool box.**

f. Connect air hoses and light cables. Push trailer air supply control knob (paragraph 2-2) IN, open trailer supply valve, and set trailer control valve hand brake.

**CAUTION**

**Backing SLOWLY helps to prevent hitting too hard in coupling and damaging king pin.**

- g. Back up slowly until fifth wheel locks firmly to king pin.
- h. Check king pin connection and fifth wheel slide locks by pulling tractor gently forward against locked trailer brakes or blocked wheels. As resistance is felt, put transmission selector lever in reverse and gently back tractor to verify fifth wheel slide locks in both directions. When resistance is felt, put transmission selector lever in Neutral (N) and set parking brake.
  - i. Verify that lock release handles are in.
  - j. Check semitrailer lights.
  - k. Stow wheel blocks.
  - l. Lift and secure semitrailer landing gear and stow float pads.

---

**2-24. UNCOUPLE FROM TRUCK (ALL EXCEPT M917A1 AND M917A1 W/MCS).**

---

**WARNING**

Use caution when uncoupling from truck. **BE ALERT** for personnel in area. Ensure that hands, arms, and body are clear of potential pinch points. Failure to follow this warning may result in injury to personnel.

**NOTE**

- **Truck and trailer must be aligned.**
- **Use ground guide if one is available.**
  - a. Stop truck and trailer.
  - b. Shift transmission into Park (P) (paragraph 2-15).
  - c. Block wheels as required.
  - d. Pull trailer air supply valve OUT.
  - e. Apply parking brake (paragraph 2-2).
  - f. Place float pads under semitrailer landing gear and lower landing gear.
  - g. Set trailer hand brake control valve and close trailer air supply valve.
  - h. Disconnect and stow trailer air supply lines and intervehicular cable.

---

**2-24. UNCOUPLE FROM TRUCK (ALL EXCEPT M917A1 AND M917A1 W/MCS) (Con't).**

---

**NOTE**

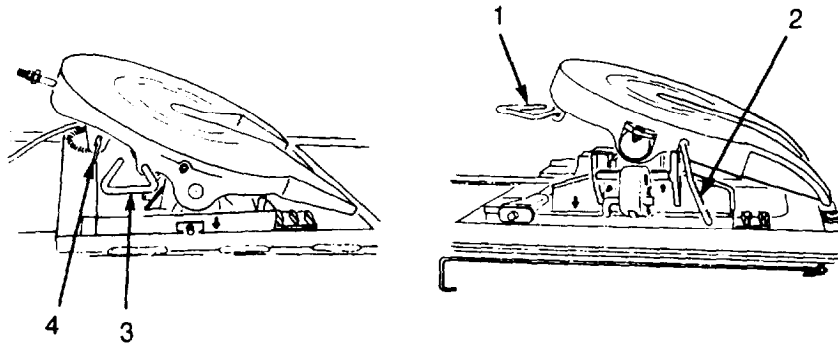
**Steps i through m apply to M915A2.**

- i. Pull secondary lock release handle (4) out and lift to engage catch.
- j. Pull primary lock release handle (3) out.
- k. Release parking brake and slowly pull forward until trailer clears fifth wheel.
- l. Stop and set parking brake.
- m. Pull trailer air supply valve OUT and disconnect and secure trailer air hoses and cables.

**NOTE**

**Steps n through q apply to M916A1 and M916A2.**

- n. Pull secondary lock release handle (1) out and raise to engage hooks on fifth wheel housing.
- o. Pull primary lock release handle (2) out and hook on fifth wheel housing.



- p. Secure trailer with winch cable (paragraph 2-28) to prevent trailer from pushing tractor from beneath it.
- q. Slowly pull truck forward until semitrailer is supported by landing gear.

---

## 2-24. UNCOUPLE FROM TRUCK (ALL EXCEPT M917A1 AND M917A1 W/MCS) (Con't).

---

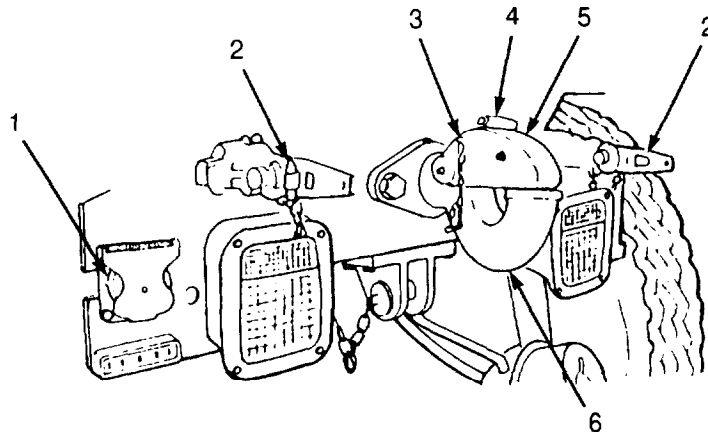
- r. Have a crew member observe semitrailer king pin to ensure that it clears during separation of tractor and semitrailer. Ensure king pin clears rear frame crossmember or tail roller when tractor is pulled forward. M870 trailers have a tendency to swing forward into rear of truck when king pin clears tail roller.
- s. Pull tractor slowly forward allowing semitrailer king pin plate or gooseneck and king pin to slide down fifth wheel and ramps until semitrailer landing gear touches ground.
- t. Disconnect and stow winch cable (paragraph 2-28).

---

## 2-25. PINTLE TOWING PROCEDURES.

---

- a. Remove cotter pin (3) engage latch (4), and lift lock (5) to open position.
- b. Connect trailer to pintle hook (6).
- c. Push lock (5) down ensuring latch (4) engages and install cotter pin (3).
- d. Connect intervehicular electric cable from receptacle (1) on rear of vehicle to trailer.
- e. Connect air hoses from quick-disconnect couplings (2) at rear of vehicle to trailer.



---

## 2-25. PINTLE TOWING PROCEDURES (Con't).

---

**WARNING**

Failure to completely turn ON or OFF air cutoff valve will cause loss of brakes on trailer or truck.

**NOTE**

See paragraph 2-22 for use of trailer handbrake.

- f. Open trailer air supply valve on hosetenna behind cab (all tractors) and push in trailer air supply knob on instrument panel.

---

## 2-26. MUD FLAP STOWAGE (ALL EXCEPT M917A1 AND M917A1 W/MCS).

---

**CAUTION**

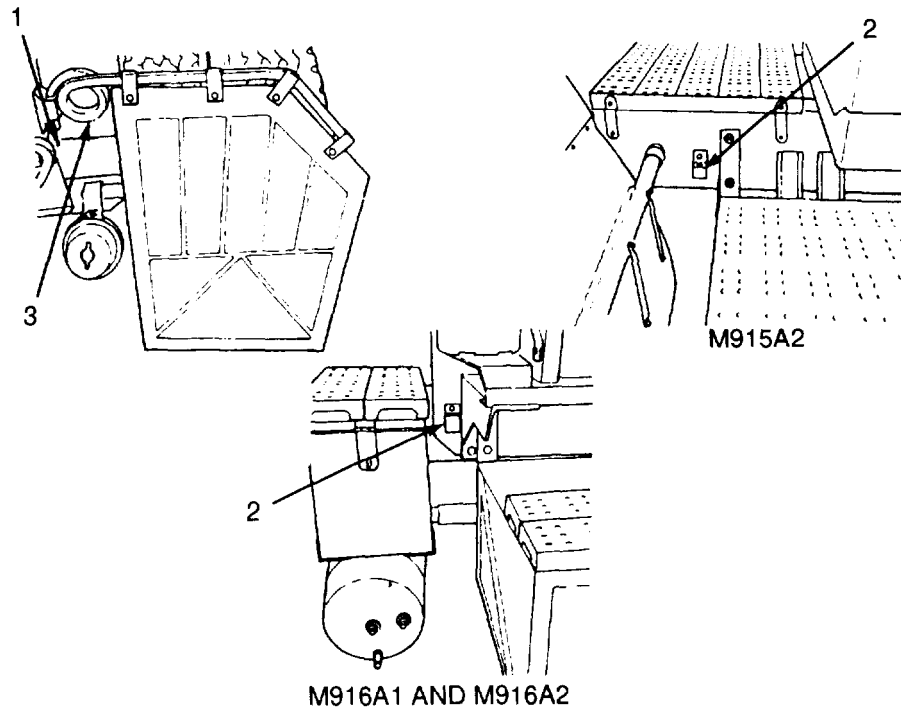
If towing M172 or M672 trailer, rear mud flaps must be removed and stowed in brackets. Failure to follow this caution may result in equipment damage.

- a. Remove lock pin (1).
- b. Pull up on mud flap (3) and remove. Tap spring upward with hammer as required.
- c. Place mud flap (3) in stowage bracket (2) and insert lock pin (1).
- d. When towing operations are complete, remove lock pin (1) and mud flap (3) from stowage bracket (2).
- e. Position mud flap (3) on vehicle and install lock pin (1).

---

**2-26. MUD FLAP STOWAGE (ALL EXCEPT M917A1 AND M917A1 W/MCS) (Con't).**

---




---

**2-27. OPERATE POWER TAKE-OFF (PTO) (ALL EXCEPT M915A2).**

---

- a. **Engage PTO.**

**CAUTION**

**Do not shift transmission with PTO engaged. Gears stop during shifting, which could cause excessive loading of PTO.**

- (1) Place transmission selector lever in neutral (N).
- (2) Operate engine at low idle and set parking brake.
- (3) On M917A1 and M917A1 w/MCS, place main light switch in STOP LIGHT or SER DRIVE position.
- (4) Place PTO switch in ON position. PTO indicator light should come on.

---

## 2-27. OPERATE POWER TAKE-OFF (PTO) (ALL EXCEPT M915A2) (Con't).

---

- (5) On M916A1 and M916A2, operate winch (paragraph 2-28).
- (6) On M917A1 and M917A1 w/MCS, operate hydraulic control lever (TM 5-3805-264-14&P).

b. **Shut Down PTO.**

- (1) On M916A1 and M916A2, release winch controls. If engine rpm was raised, reduce rpm using throttle control switch.
- (2) On M917A1 and M917A1 w/MCS, place hydraulic control in Neutral (N) (TM 5-3805-264-14&P).
- (3) On M917A1 and M917A1 w/MCS, place main light switch to OFF position.
- (4) Place PTO switch to OFF position. PTO indicator light will go out.

---

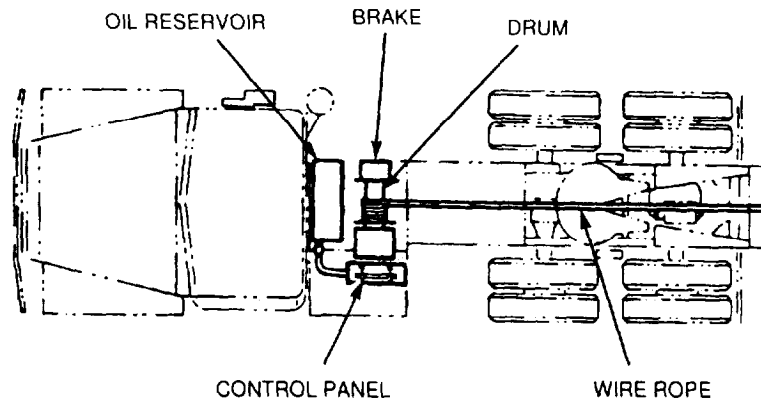
## 2-28. OPERATE WINCH (M916A1 AND M916A2).

---

a. **General.**

(1) M916A1 and M916A2 tractors are equipped with a full hydraulic winch mounted on the frame behind the cab. The winch has a fail safe spring-loaded brake that automatically sets any time the winch control valve is in neutral or there is a power failure (hydraulic pressure drops to less than 200 psi).

(2) The winch operates at 2100 psi hydraulic pressure from a dual pump driven by a PTO on the transmission. The rated capacity of the winch is 45,000 lb (20,250 kg). For more information, refer to TM 5-725.





---

**2-28. OPERATE WINCH (M916A1 AND M916A2) (Con't).**


---

(3) The winch operator's station is located on left side of the tractor behind the cab. The operator stands on the platform provided and operates the winch using the controls on top of the control panel.

<b>WARNING</b>
----------------

- Always wear heavy gloves when handling winch cable. Never allow cable to run through hands; frayed cables can cut you. Never operate winch with less than four turns of cable on drum. Keep cable coils tight and close together on drum while winching. Failure to follow this warning may result in injury to personnel.
- Hearing protection is required for operator and personnel working around winch station during operation.
- DO NOT use winch for moving or lifting people. Serious injury could result.

<b>CAUTION</b>
----------------

Keep trailer air supply hoses away from wire rope to prevent damage to hoses.

**NOTE**

Rated winch pull is set by limiting hydraulic system relief valve pressure to maximum of 2500 psi, which provides 45,000 lb (20,250 kg) pull on bare drum. As winch drum is loaded with wire rope, effective line pull is reduced. The line per cable layer with 7/8-inch wire rope is:

1 st layer 45,000 lb (20,250 kg)
2nd layer 39,265 lb (17,810 kg)
3rd layer 34,775 lb (15,773 kg)
4th layer 31,210 lb (14,156 kg)
5th layer 28,310 lb (12,841 kg)

b. **Operate Winch.**

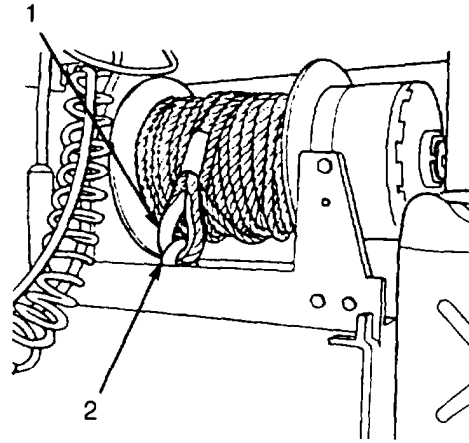
- (1) Engage PTO (paragraph 2-27).

---

**2-28. OPERATE WINCH (M916A1 AND M916A2) (Con't).**

---

(2) Have a crew member disconnect wire rope eye (1) from anchor (2).



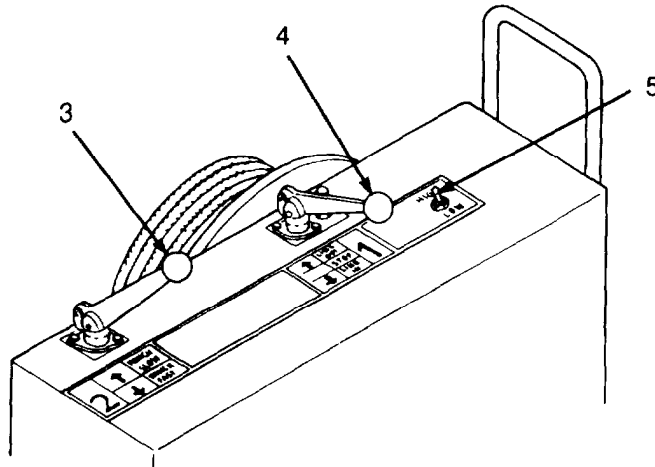
(3) To pay out wire rope, pull up and hold line control lever (4) in LINE OUT position. Winch unwinds in low speed. Have crew member walk end of wire rope out.

**NOTE**

**High-speed winch operation is only recommended for paying out wire rope or taking up slack.**

(4) To run winch at high speed, set throttle control (5) to HIGH and push down and hold speed control lever (3).

(5) When desired amount of line has been payed out, stop winch by releasing both control levers. Set throttle control (5) to LOW.



**2-28. OPERATE WINCH (M916A1 AND M916A2) (Con't).**

- (6) Direct crew member to disconnect wire rope from payload.
- (7) Have crew member pull on wire rope and keep fairly taut and start rewinding drum by pushing down on winch line control lever (4).
- (8) Ensure that wire rope winds neatly onto drum without tangling, kinking, twisting, or overlapping. Ensure that coils on drum are tight and close together.
- (9) Direct crew member to signal when enough slack has been taken up to anchor the eye.
- (10) Have a crew member anchor wire rope eye (1) to anchor (2).
- (11) Shut down PTO (paragraph 2-27).

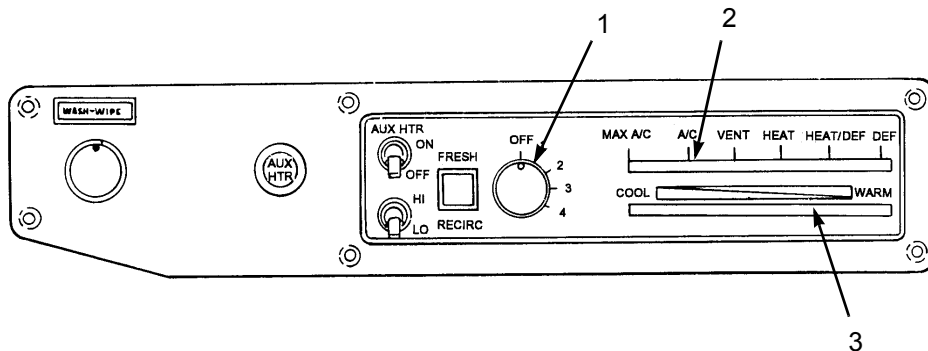
**2-29. OPERATE AIR CONDITIONER (ALL EXCEPT M915A2 AND M916A1).**

- a. If cab is hot inside, open windows and allow hot air to vent.
- b. Move mode control lever (2) to VENT and turn fan switch (1) to OFF position.
- c. Start engine (paragraph 2-14).

**NOTE**

**If outside air is dusty or smoky, mode control lever should be set to MAX A/C and windows and vent closed to prevent drawing dust or smoke into cab.**

- d. Move mode control lever (2) to A/C. With control at A/C, fresh air is drawn into cab. With control at MAX A/C, air inside cab is recirculated.
- e. Move temperature control lever (3) to COOL.

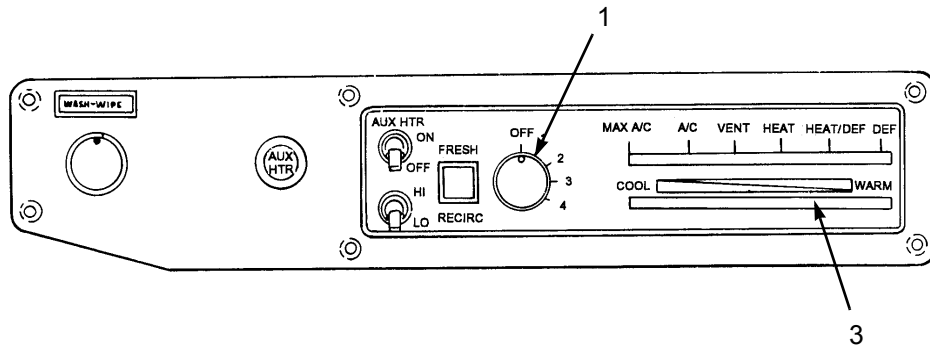


---

**2-29. OPERATE AIR CONDITIONER (ALL EXCEPT M915A2 AND M916A1 (Con't)).**

---

- f. Turn fan switch (1) to 4 (highest speed).
- g. As soon as cool air is flowing from dashboard outlets, close windows.
- h. Adjust temperature control lever (3) and fan switch (1) as required.



---

**2-30. OPERATE PORTABLE FIRE EXTINGUISHER.**

---

**WARNING**

Discharging large quantities of dry chemical fire extinguisher in the cab may result in temporary breathing difficulty during and immediately after the discharge event. If at all possible, discharge fire extinguisher from outside the cab. Ventilate cab thoroughly prior to reentry.

**NOTE**

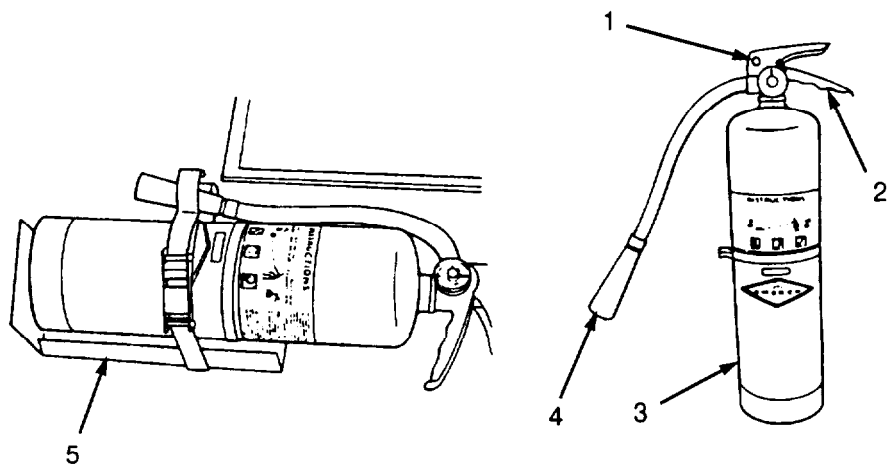
This is a type B and C fire extinguisher. Use on oil and electrical fires only.

- a. Remove fire extinguisher (3) from bracket (5) located between passenger seat and shift tower.
- b. Hold fire extinguisher (3) upright. Point nozzle (4) toward base of fire and pull safety pin (1).
- c. Squeeze lever (2), discharging chemical at base of fire. Use a side-to-side motion to spread chemical.
- d. After using fire extinguisher, notify Unit Maintenance.

---

**2-30. OPERATE PORTABLE FIRE EXTINGUISHER (Con't).**

---



---

**2-31. OPERATE LIGHTS.**

---

**NOTE**

**If engine is not running, ignition switch must be in ON position for lights to operate.**

a. **Operate Beacon Warning Light.**

(1) Move beacon light switch up to turn on beacon warning light (1). BCN LT indicator (4) should come on.

(2) Move beacon light switch down to turn off beacon warning light (1).

b. **Operate Work Lights.**

(1) Connect work light plug into receptacle (3).

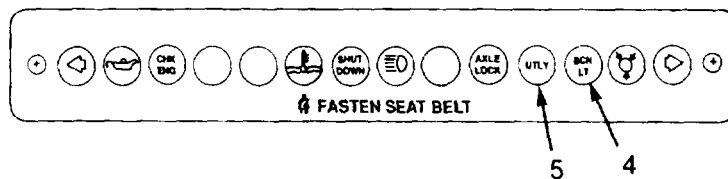
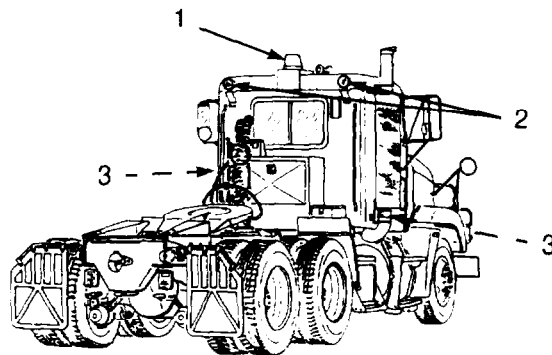
(2) Place ignition key in ON position and main light switch in STOP LIGHT or SER DRIVE position.

(3) Position ignition key in OFF position and disconnect work light plug from receptacle (3).

c. **Operate Utility Lights (All Except M917A1 and M917A1 w/MCS).**

(1) Place ignition key in ON position and move utility light switch up to turn utility lights (2) on. UTTY light indicator (5) should come on.

(2) Move utility light switch down and place ignition key in OFF position.

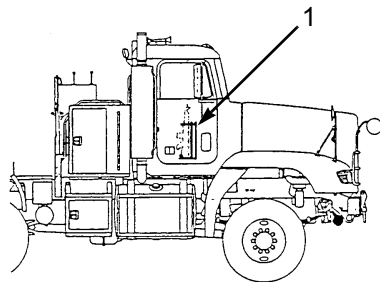


---

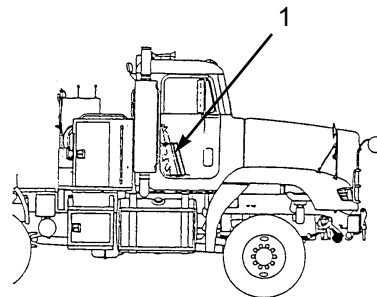
## 2-32. RIFLE MOUNTING KIT.

---

- a. For M915A2 and M916A1, rifle mounting kit (1) is located next to shift control.
- b. For all except M915A2 and M916A1, rifle mounting kit (1) is located behind shift tower against back wall of cab.



M915A2 AND M916A1



ALL EXCEPT M915A2 AND M916A1

---

## 2-33. OPERATE HEATER AND DEFROSTER.

---

### NOTE

**Heater and defroster obtain heat from engine as it runs.  
If engine is not running, heat will not be available for  
these functions.**

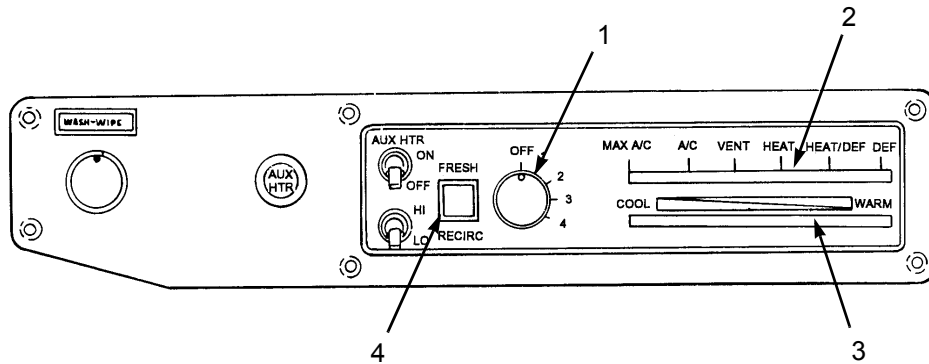
- a. Start engine (paragraph 2-14) and bring truck to normal operating temperature.

---

### 2-33. OPERATE HEATER AND DEFROSTER (Con't).

---

- b. Slide mode control lever (2) to desired position.
- c. Slide temperature control lever (3) to desired temperature range.
- d. Rotate fan switch (1) to adjust fan speed from slower to faster, as desired.
- e. Press FRESH/RECIRC air button (4) to desired setting.



---

### 2-34. PREPARATION FOR MOVEMENT.

---

**WARNING**

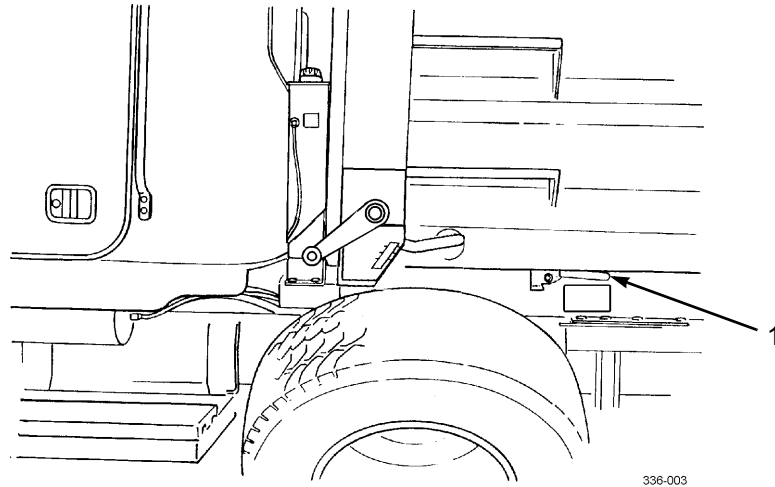
- Lifting cables, chains, hooks, and slings used for lifting truck must be in good condition and of suitable capacity. Failure to follow this warning may result in injury or death to personnel and damage to equipment.
- Improper use of lifting equipment and improper attachment of cables to vehicle can result in serious personnel injury and equipment damage. Observe all standard rules of safety.
  - a. For M917A1 and M917A1 w/MCS, place transport lock (1) in LOCKED position.
  - b. To lift vehicle, attach suitable lifting device to lifting shackles. Lift vehicle slowly and have observers watch for any signs of cable failure, unusual load shifts, and obstructions.
  - c. During transport, secure vehicle by attaching cables to tiedown points.



---

**2-34. PREPARATION FOR MOVEMENT (Con't).**

---





## Section IV. OPERATION UNDER UNUSUAL CONDITIONS

Paragraph Number	Paragraph Number	Page Number
2-35.	General . . . . .	2-121
2-36.	Slave Start Truck . . . . .	2-122
2-37.	Tow Truck . . . . .	2-123
2-38.	Cage and Uncage Brakes . . . . .	2-133
2-39.	Operate in Extreme Cold . . . . .	2-127
2-40.	Operate in Extreme Heat . . . . .	2-131
2-41.	Operate in Mud or Soft Surfaces . . . . .	2-132
2-42.	Fording . . . . .	2-133
2-43.	Operate in Sandy or Dusty Conditions . . . . .	2-134
2-44.	Operate in Woods or On Rocky Terrain . . . . .	2-135
2-45.	Operate on Snow or Ice . . . . .	2-136
2-46.	Driving with a Damaged Tire (M917A1 and M917A1 w/MCS . . . . .	2-140

---

### 2-35. GENERAL.

---



**These vehicles have been designed to operate safely and efficiently within the limits specified in this TM. Operation beyond these limits is prohibited in accordance with AR 70-1 without written approval from: Commander, U.S. Army Tank-automotive and Armaments Command, ATTN:AMSTA-DSA-CS, Warren, MI 48397-5000.**

- a. This section contains instructions for safely operating the M915 Family of Vehicles under unusual conditions. In addition to normal preventive maintenance, special care must be taken to keep truck operational in extreme temperatures and other environmental conditions.
- b. Refer to FM 21-300 and FM 21-305 for additional information.

---

## 2-36. SLAVE START TRUCK.

---

**WARNING**

- When slave starting truck, use NATO slave cables that DO NOT have loose or missing insulation.
- DO NOT proceed if suitable cables are not available.
- DO NOT use civilian-type jumper cables.
- Failure to follow this warning could result in injury.

**CAUTION**

- If “dead” truck’s engine does not start within 30 seconds, release engine start button. Wait three to five minutes before repeating procedure to prevent overheating the starter and damaging batteries of “live” vehicle. If engine does not start after several attempts, Unit Maintenance must perform additional maintenance.
- Under no circumstances can the truck be started by being towed or pushed. Failure to follow this caution will cause damage to transmission.

**NOTE**

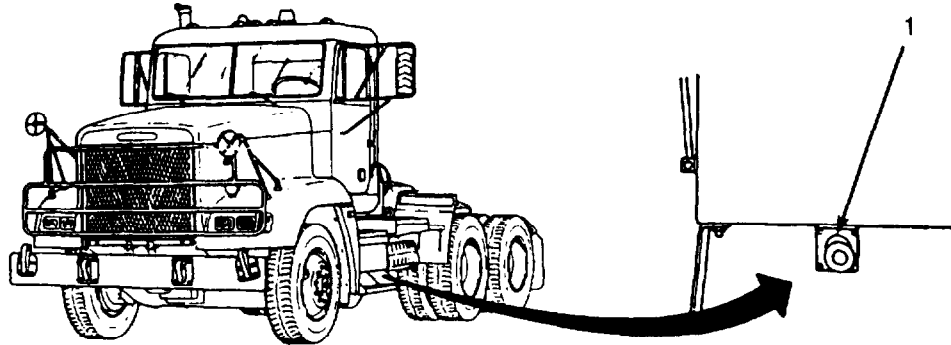
- Before slave starting, ensure that checks have been made to determine whether problem is low or dead battery.
- If vehicle other than another M915 family vehicle is used to slave start truck, refer to Operator’s Manual for that vehicle for any special slave starting procedures.
  - a. **Normal Slave Starting.**
    - (1) Connect NATO slave cable to receptacle (1) on “dead” vehicle.
    - (2) Connect other end of NATO slave cable to receptacle on “live” vehicle.
    - (3) Start engine of “live” vehicle and run at 1000 rpm for 15-20 minutes. Stop engine and remove NATO slave cable from receptacle.

---

## 2-36. SLAVE START TRUCK (Con"t).

---

(4) Start engine of "dead" vehicle (paragraph 2-14). If engine will not start, Notify Unit Maintenance.



### b. Emergency Slave Starting.

- (1) Connect NATO slave cable to receptacle (1) on "dead" vehicle.
- (2) Connect other end of NATO slave cable to receptacle on "live" vehicle.
- (3) Start engine of "live" vehicle and run at 700 rpm.
- (4) Start engine of "dead" vehicle (paragraph 2-14) and allow both vehicles to idle for five to ten minutes. If engine will not start, notify Unit Maintenance.
- (5) Remove NATO slave cable from receptacle on "live" vehicle.
- (6) Remove NATO slave cable from receptacle (1) on "dead" vehicle.

---

## 2-37. TOW TRUCK.

---

### a. General.

- (1) Notify Unit Maintenance to send tow vehicle, TM 9-2320-363-20, and tools required to remove propeller shafts.
- (2) Refer to FM 21-305 for general guidelines on vehicle recovery and use of warning kits and signals. Refer to FM 21-305 and FM 20-22 for additional information.

---

## 2-37. TOW TRUCK (Con't).

---

(3) When towing vehicle with front axle and rear tandem on ground, ensure that interaxle lockout (all-wheel drive) control valve switch is in UNLOCK (DISENGAGE) position. Ensure that universal joint on rear of propeller shaft (at the input to the forward-rear axle) is disconnected and tied up to vehicle undercarriage.

(4) When front axle of vehicle being towed is lifted off the ground, disconnect universal joint on propeller shaft (at the input to the forward-rear axle) and tie it up to vehicle undercarriage.

(5) When rear tandem axles of vehicle being towed are lifted off ground, ensure interaxle lockout (all-wheel drive) control valve switch is in UNLOCKED (DISENGAGE) position. Place transfer case selector lever in Neutral (N) position.

### **CAUTION**

**Propeller shafts must be disconnected to prevent operation of transfer case and interaxle lockout (all-wheel drive) control valve switch must be in UNLOCK (DISENGAGE) position before towing vehicle. Failure to follow this caution may result in transmission damage.**

### **NOTE**

**Towing vehicle speed should not exceed 15 mph on primary roads and 8 mph on secondary roads. For cross-country towing, all tires of disabled vehicle should be on ground.**

#### **b. Towing Procedures.**

(1) Install medium duty tow bar at towing vehicle pintle and disabled vehicle towing eyes. Ensure tow bar is long enough to allow complete turning radius.

(2) Connect air pressure hoses between disabled vehicle and towing vehicle. Quick-disconnect gladhands are located behind rear bumper.

(3) Release parking brakes and turn appropriate lights on

---

## 2-38. CAGE AND UNCAGE BRAKES.

---

a. **Cage Brakes.** In the event of an air pressure loss, spring brakes on the tandem rear axles will apply the brakes. If the vehicle must be towed and there is not enough air system pressure to compress the power spring in the spring brake chambers to release the brakes, compress them manually. Each vehicle has four spring brakes.

<b>WARNING</b>
----------------

- **Brake chamber contains spring under great pressure. To prevent personnel injury, never work directly behind chamber. If caging bolt will not engage properly, spring may be broken.**
- **Do not remove clamp ring around spring brake chamber. It is under tension and can cause personnel injury if released.**
- **When spring brakes are applied, vehicle will stop quickly which could result in injury to personnel. Also, vehicle cannot be driven again until malfunction is repaired and enough air supply is present for operation of service brakes.**
- **When caging brakes, block wheels to keep truck from moving when brakes are released. Failure to follow this warning may result in death or injury to personnel or damage to equipment.**

(1) Block wheels.

---

**2-38. CAGE AND UNCAGE BRAKES (Con't).**

---

(2) Remove nut (4) washer (5), and release stud (2) from stowage pocket (1).

(3) Remove cap (3) from spring chamber (6).

(4) Insert cross-pin end of release stud (2) into opening where cap (3) was removed.

(5) To engage cross-pin, rotate release stud (2) until cross-pin end goes into slot inside of spring chamber (6). Turn release stud right ¼ turn; cross-pin is now engaged.

(6) Install washer (5) and nut (4) on release stud (2).

(7) Tighten nut (4) until approximately 3 in. of release stud (2) shows above nut. Spring brake is fully released.

**b. Uncage Brakes.**

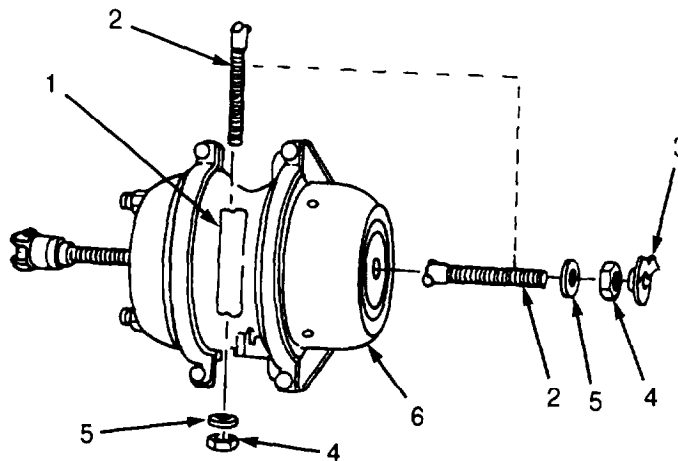
(1) Block wheels.

(2) Remove nut (4) and washer (5) from release stud (2).

(3) Turn release stud (2) to left ¼ turn and remove release stud from spring chamber (6).

(4) Install cap (3) in spring chamber (6).

(5) Insert release stud (2) into stowage pocket (1) and install washer (5) and nut (4) on release stud.





---

**2-39. OPERATE IN EXTREME COLD.**

---

a. **General.**

- (1) Extreme cold causes many problems:
  - (a) Lubricants thicken or congeal.
  - (b) Batteries may freeze or lose their electrical efficiency.
  - (c) Fuel may not readily atomize for combustion.
  - (d) Various materials will become hard, brittle, and easily damaged.
  - (e) The cooling system requires adequate protection from extreme cold.
  - (f) Fuels, lubricants, and antifreeze compounds require special storage, handling, and use.
- (2) Refer to FM 9-207 for additional information.
- (3) Winterization Kit. All vehicles assigned to arctic regions are equipped with a winterization kit which protects vehicle systems from freeze damage and enables easier starting.
- (4) Starting Out.
  - (a) Be careful when you first start your vehicle. Use cold weather starting procedure (paragraph 2-14) and allow engine time to reach operating temperature range of 120-140°F (48-59°C). Be alert that tires may be frozen to ground.
  - (b) Start driving very slowly for about 100 yards (91.4 m). Be alert for signs that tires may have flat spots or that one or more brake shoes may be frozen and require preheating. Notify Unit Maintenance as required.
- (5) Parking.
  - (a) If vehicle will be parked for a short period, park in a sheltered area out of wind. If shelter is not available, park vehicle so it does not face into the wind.
  - (b) If vehicle will be parked for a long shutdown period, try to park on high ground and use planks or brush to make a raised and relatively dry surface. Keep tires out of snow, water, ice, and mud, if possible.
  - (c) Clean snow, ice, and mud from vehicle as soon as possible after shutdown.
  - (d) If vehicle will be parked for a long period of time, have Unit Maintenance remove and store batteries. Fill fuel tank to guard against condensation and drain any accumulated water from air reservoirs and fuel filters.
  - (e) Ensure tires are properly inflated.

**2-39. OPERATE IN EXTREME COLD (Con't).**

(f) Have Unit Maintenance check and service cooling system to ensure truck is adequately protected against extreme cold. Ensure transmission is in NEUTRAL (N) position and vehicle tires are blocked.

**b. Operate Artic Personnel Heater Kit.**

**NOTE**

**Auxiliary heater (AUX HTR) indicator light illuminates only when burner is lit. Indicator light turns on and off automatically. Initial time required for indicator light to light depends on outside temperature.**

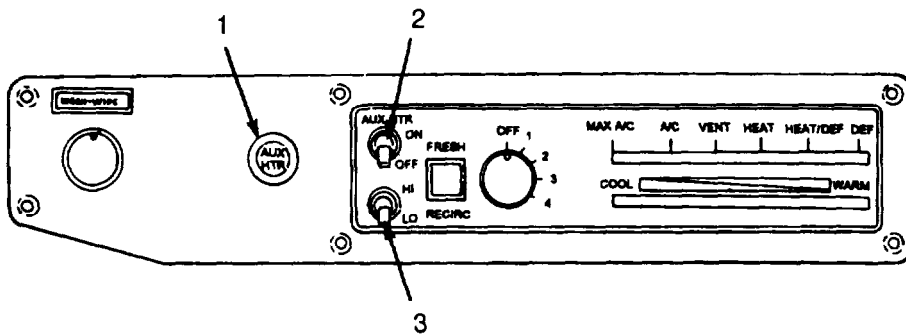
(1) Place AUX HTR switch (2) in ON position. AUX HTR light (1) will light when heater burner is lit.

**NOTE**

**If HI-LO switch is set to HI position, heater will automatically switch to low heat when temperature of coolant at heater inlet reaches 160°F. LO position is suitable when heater operates over an extended period.**

(2) Place HI-LO switch (3) to desired setting.

(3) To turn heater off, place AUX HTR switch (2) to OFF position. Heater burner will stop and AUX HTR light will go out within a few minutes, but blower will continue to run for approximately one minute.



**c. Operate Arctic Swing Fire Heater Kit.**

- (1) Check fuel level in heater (7). Add fuel as required.
- (2) Check air shutoff valve by pushing pressure pin (10). Pressure pin is spring-loaded and must bounce back.
- (3) Loosen wing nut (9) fully and check gasket for proper position.
- (4) Push heater (7) in heat exchanger (8) and tighten wingnut (9).

---

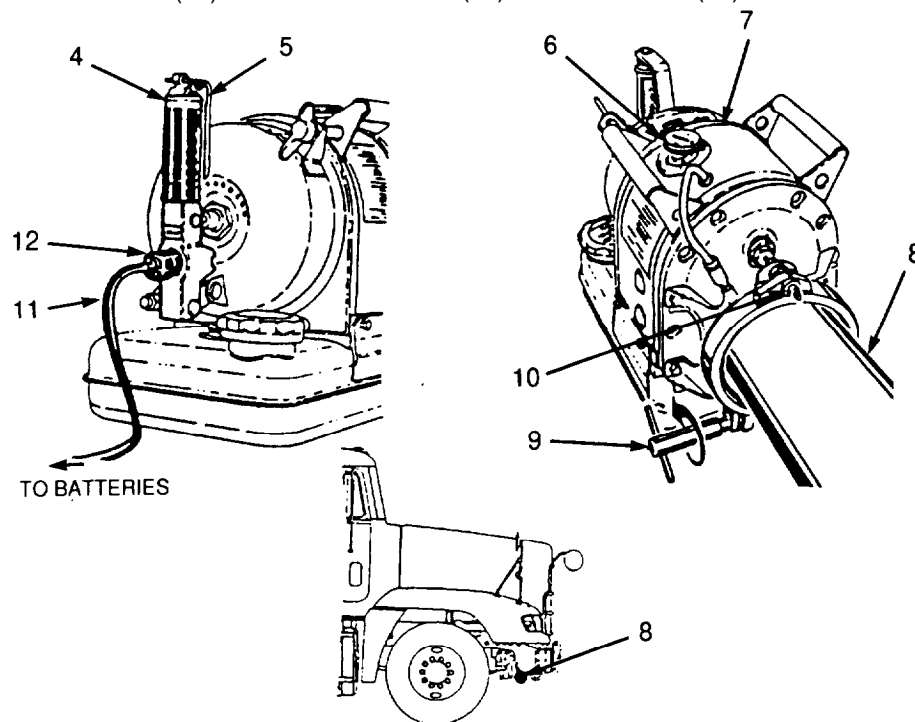
**2-39. OPERATE IN EXTREME COLD (Con't).**


---

**CAUTION**

**Battery voltage must be the same as voltage indicated on heater hand pump lever. Incorrect voltage may cause damage to equipment.**

- (5) Connect cable (11) to connector (12) and batteries.
- (6) Close fuel regulator (6).
- (7) Squeeze ignition switch (4) on pump lever (5) and actuate pump.
- (8) After three or four strokes, open fuel regulator (6) 1/2 to 1 turn while continuing to pump.
- (9) Adjust fuel regulator (6) until pulsating sounds come in equal intervals. Stop pumping.
- (10) After three to five minutes, adjust fuel regulator (6) until pulsating evens out.
- (11) Disconnect cable (11) from connector (12) and batteries.



---

**2-39. OPERATE IN EXTREME COLD (Con't).**

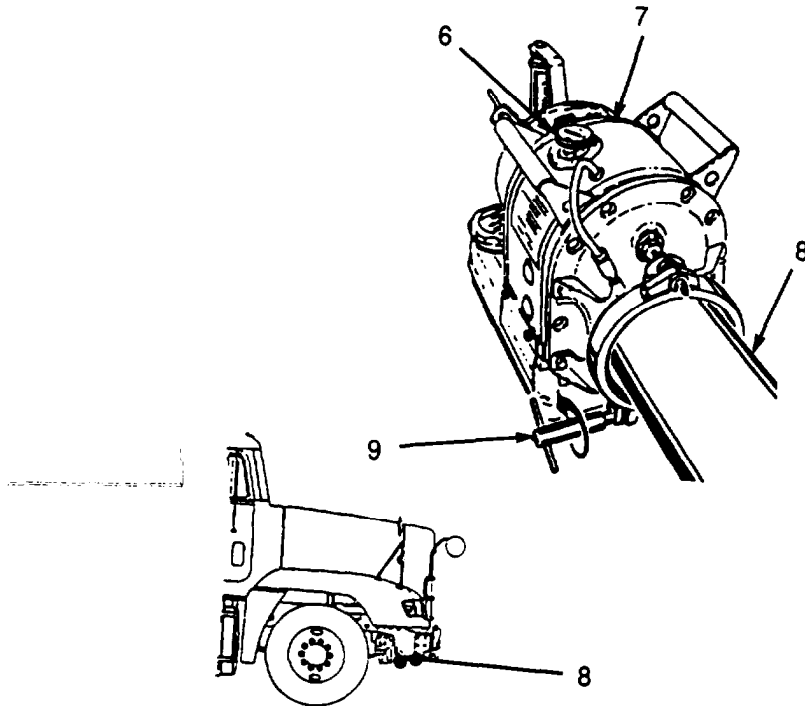
---

(12) To turn heater off, close fuel regulator (6) completely. When pulsating stops, heater is off.

**WARNING**

**Allow heater enough time to cool. Failure to do so could result in injury to personnel.**

(13) Loosen wing nut (9) and remove heater (7) from heat exchanger (8).



---

**2-39. OPERATE IN EXTREME COLD (Con't).**

---

d. **Operate Winch.****CAUTION**

**Avoid winching operations that cause sudden shock loads. In extremely cold temperatures, metals become brittle and sudden shock loads can cause equipment damage.**

- (1) Before operating winch, warm up hydraulic system by turning PTO switch ON and operating engine at approximately 1000 rpm for ten minutes.
- (2) When hydraulic system is warmed up, operate winch in no-load condition by paying out approximately 25 ft (7.6 m) of cable at low speed.
- (3) Take up cable at low speed.
- (4) Winch should be ready for normal operation.

---

**2-40. OPERATE IN EXTREME HEAT.**

---

a. **General.** During very hot weather, driving procedures may require altering to prevent vehicle overheating. Avoid continuous high speeds, long, hard pulls, and continuous operation in soft terrain.

b. **Driving Vehicle.**

- (1) Check water temperature gage and stop if temperature is unusually high. Allow vehicle to cool down.
- (2) Check cooling system, air cleaner, air cleaner restriction indicator, engine oil level, and radiator fins frequently. Perform necessary services and notify Unit Maintenance of any unusual gage readings or problems.
- (3) Notify Unit Maintenance to shorten differential oil change interval.

c. **Parking Vehicle.**

- (1) Park vehicle under cover, if possible. If shelter is not available, cover vehicle with tarpaulins. If there aren't enough tarps to cover entire vehicle, arrange tarps around engine compartment and over radiator to keep sand and dust out. Cover window glass to protect against sand blasting.
- (2) Ensure all tires are inflated to proper pressure.
- (3) Check frequently for rust and fungus growth. Clean and lubricate vehicle to help prevent deterioration.

---

## 2-41. OPERATE IN MUD OR SOFT SURFACES.

---

### NOTE

- **M915A2 is equipped with No Spin® automatic locking positive traction differential on the forward-rear axle; all vehicles except M915A2 are equipped with No Spin® on both rear axles. The No Spin® differential eliminates individual wheel spinout for better traction.**
- **When locking system is engaged, driving axles receive equal torque.**
  - a. Before entering mud or other soft surfaces, check conditions and select appropriate transmission gear range. LOCK (ENGAGE) interaxle lockout (all-wheel drive). Enter soft area at a medium speed for gear range selected.
  - b. For M917A1 and M917A1 w/MCS, select appropriate tire pressure on CTIS selector panel (paragraph 2-17).
  - c. Maintain steady pressure on accelerator pedal to keep vehicle rolling until solid ground is reached. Do not accelerate to point where wheels spin and do not stop, if possible.
  - d. If vehicle gets stuck, try to pull out slowly in a low gear. Boards, brush, or similar materials may be placed under tires to provide traction.

**WARNING**

**When resuming operation on highway surfaces, be sure to reset CTIS selector panel to higher tire pressures. Operating vehicle with underinflated tires will cause premature tire wear or damage to tires. Failure to follow this warning may result in death or injury to personnel.**

- e. If M917A1 or M917A1 w/MCS gets stuck, select emergency (EMER) on CTIS selector panel to reduce tire pressures to 30 psi (207 kPa). Do NOT exceed 10 mph (16 kph). Operation in this mode is limited to 10 minutes unless reselected. Reset to higher tire pressures when vehicle is freed.
- f. If M916A1 or M916A2 gets stuck and is not coupled to trailer, winch may be used. Attach winch cable to another vehicle or heavy object that will not move under load.
- g. When vehicle reaches hard surface, place interaxle lockout (all-wheel drive) in UNLOCK (DISENGAGE) position.

---

**2-42. FORDING.**

---

**a. General.**

- (1) Maximum fording depth is 20 in. (50.8 cm).
- (2) Ford to maximum depth for short periods and short distances only. Vehicles can ford to maximum depth for five minutes without requiring maintenance to continue operation.

**b. Before Fording.**

- (1) Check bottom surface of water to ensure it is hard enough to be forded without exceeding maximum fording depth.
- (1) Ensure that engine is operating properly.
- (2) Lubricate unpainted surfaces to guard against rust and deterioration.
- (3) Place interaxle lockout (all-wheel drive) control valve in LOCK (ENGAGE) position.

**c. During Fording.**

- (1) Place transmission in a low gear (paragraph 2-15) and enter water slowly.
- (2) Ford at speeds of 3-4 mph (5-6 kph).

**d. After Fording.**

- (1) When vehicle emerges from water, apply brakes a few times to dry brake linings. Ensure that brakes are working properly before driving at normal speeds.
- (2) Allow engine to run for awhile to drive out any accumulated water.
- (3) Drain or dry any area where water has accumulated.
- (4) Check all fluids for signs of contamination and for proper levels. (Appendix F).
- (5) If vehicle has been operated in salt water, rinse undercarriage immediately. Allow exterior to dry and check for evidence of salt accumulation. Use a clean, damp cloth to immediately remove all salt accumulation.
- (6) Notify Unit Maintenance that after-fording lubrication is required.

---

## 2-43. OPERATE IN SANDY OR DUSTY CONDITIONS.

---

### NOTE

- **M915A2 is equipped with No Spin® automatic locking positive traction differential on the forward-rear axle; all vehicles except M915A2 are equipped with No Spin® on both rear axles. The No Spin® differential eliminates individual wheel spinout for better traction.**
- **When locking system is engaged, driving axles receive equal torque.**
  - a. Maintain steady, even movement with transmission in lower gears and interaxle lockout (all-wheel drive) in LOCK (ENGAGE) position. Try to keep vehicle rolling without straining engine and powertrain.
  - b. For all vehicles except M917A1 and M917A1 w/MCS, if vehicle gets stuck, reduce tire pressure to gain additional traction. Reduce pressure in front tires to 50 psi and pressure in rear tires to 45 psi (302 kPa). Inflate tires to normal pressures once vehicle is freed.

**WARNING**

**When resuming operation on highway surfaces, be sure to reset CTIS selector panel to higher tire pressures. Operating vehicle with underinflated tires will cause premature tire wear or damage to tires. Failure to follow this warning may result in death or injury to personnel.**

- c. For M917A1 and M917A1 w/MCS, select SAND mode key on CTIS selector panel.
- d. If M917A1 or M917A1 w/MCS gets stuck, select emergency (EMER) on CTIS selector panel to reduce tire pressures to 30 psi (207 kPa). Do NOT exceed 10 mph (16 kph). Operation in this mode is limited to 10 minutes unless reselected. Remember to reset to higher tire pressures when vehicle is freed.
- e. If vehicle bogs down, after tire pressure has been reduced, place boards, brush, canvas, or similar materials under and in front of tires after shoveling a clear path ahead of each tire. This should improve traction.
- f. If these efforts fail and it becomes evident that vehicle will not free itself, use winch (M916A1/M916A2), if possible, or have another vehicle tow stuck vehicle.



---

**2-43. OPERATE IN SANDY OR DUSTY CONDITIONS (Con"t).**

---

- g. Whenever operating in sandy or dusty areas, you should:
- (1) Make sure each tire has a valve cap.
  - (2) Check engine and transmission temperature and engine oil pressure frequently.
  - (3) If vehicle overheats, stop and find out why. Service or notify Unit Maintenance, as necessary.
  - (4) Make sure engine oil filler tube and transmission fluid filler tube are cleaned before dipsticks are removed to check fluid levels. Clean accumulations of sand and dirt from around any fluid filler locations before checking or adding fluids.
  - (5) Clean spouts of fuel containers and areas around filler caps on fuel tanks before adding fuel. Under extremely sandy or dusty conditions, filter fuel when filling tanks.
  - (6) Cover window glass to protect against sand blasting.

---

**2-44. OPERATE IN WOODS OR ON ROCKY TERRAIN.**

---

**NOTE**

- **M915A2 is equipped with No Spin® automatic locking positive traction differential on the forward-rear axle; all vehicles except M915A2 are equipped with No Spin® on both rear axles. The No Spin® differential eliminates individual wheel spinout for better traction.**
  - **When locking system is engaged, driving axles receive equal torque.**
  - **For all vehicles except M915A2, shift transfer case selector to LOW range if operating in extremely slippery conditions or while climbing steep inclines.**
- a. Ensure vehicle can clear any obstructions and try to avoid low hanging tree limbs which might cause damage.

---

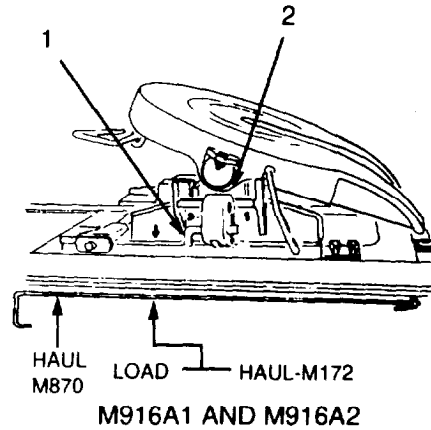
**2-44. OPERATE IN WOODS OR ON ROCKY TERRAIN (Con't).**

---

b. Ensure spare wheel and tire assembly is available.

c. For M916A1 and M916A2, release fifth wheel (oscillating) travel lockout by removing locking pin (1) lowering lockout (2) and reinserting locking pin (1). This allows fifth wheel to oscillate side-to-side.

d. For M917A1 and M917A1 w/MCS, select cross-country (X-C) mode on CTIS selector panel (paragraph 2-17).




---

**2-45. OPERATE ON SNOW OR ICE.**

---

**NOTE**

- M915A2 is equipped with No Spin® automatic locking positive traction differential on the forward-rear axle; all vehicles except M915A2 are equipped with No Spin® on both rear axles. The No Spin® differential eliminates individual wheel spinout for better traction.
- When locking system is engaged, driving axles receive equal torque.
- For all vehicles except M915A2, shift transfer case selector to LOW range if operating in extremely slippery conditions or while climbing steep inclines.

a. **General.**

- (1) **Driving.**
- (a) Accelerate slowly to avoid spinning tires.
  - (b) Drive at slower speeds.

---

**2-45. OPERATE ON SNOW OR ICE (Con't).**

---

- (c) Give signals sooner.
- (d) Apply brakes sooner to give early warning of intention to stop. This will also help to avoid skidding.
- (e) Maintain double the normal distance from the vehicle ahead.
- (f) Keep windshields, windows, mirrors, headlights, stop-lights, and body lights clean and free of snow and ice. Use defroster to help keep glass free of snow and ice.
- (g) Descend moderate grades in gear normally used for ascending same grade. On steep or very slippery grades, LOCK (ENGAGE) Interaxle Lockout (All-Wheel Drive) Control Valve and use at least one gear lower.
- (h) After driving through slush or water, drive slowly and test brakes. Keep driving slowly, maintaining moderate pressure on service brake pedal to create a slight drag. When brakes are dry and operating properly, resume normal speed.
- (i) If a difficult stretch of road approaches, stop and inspect it carefully before driving on it. Select transmission gear range that best suits road condition and LOCK (ENGAGE) Interaxle Lockout (All-Wheel Drive).
- (j) If vehicle becomes stuck or tires start spinning, it may be possible to rock vehicle out. LOCK (ENGAGE) Interaxle Lockout (All-Wheel Drive) and shift transmission to D (DRIVE). Apply light, steady throttle (never full throttle). When vehicle has moved as far as it will go, apply service brakes and allow engine to return to idle speed. Shift transmission to R (REVERSE). Again, apply light, steady throttle and allow vehicle to move rearward as far as it will go. Apply service brakes and allow engine to return to idle speed. This procedure can be continued as long as each directional shift moves vehicle a greater distance. If not, vehicle should be towed from its position.

(2) **Stopping.**

- (a) Ease up on accelerator, leaving vehicle in gear.
- (b) Apply service brakes lightly and evenly. Do NOT pump service brake pedal.

---

**2-45. OPERATE ON SNOW OR ICE (Con't).**

---

**WARNING**

**Do not use engine brake if road surfaces are slippery. Using engine brake on wet, icy, or snow covered roads could result of loss of vehicle control. Failure to follow this warning could result in death or injury to personnel or damage to equipment.**

(c) Always avoid sudden braking and use of engine brake on slick roads.

(d) All vehicles have Anti-Lock Brake System (ABS) and have the advantage of easier handling and controllability during emergency stops. During emergency or reduced traction stops, press brake pedal fully until vehicle comes to a safe stop. DO NOT PUMP brake pedal. With brake pedal fully depressed, ABS will control all wheels to provide steering control and a reduced braking distance.

(3) **Parking.** If parking on icy, slushy, wet, or muddy surfaces, place boards, brush, or other materials that will provide traction underneath tires. This will guard against tires freezing to the ground or becoming pocketed in ice, and will provide some traction when vehicle is started and moving again.

b. **Install Tire Chains.**

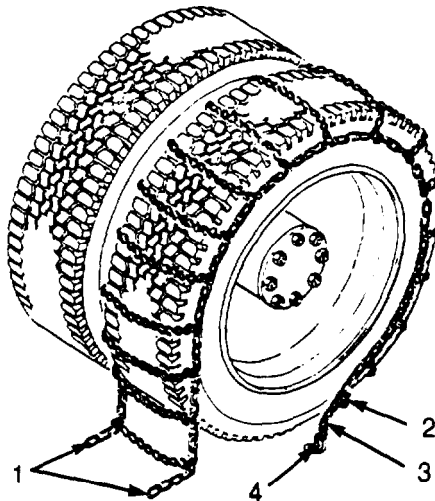
(1) Lay out chains flat on ground alongside tire to be mounted. Untangle any cross chains.

(2) Open all cams (4) (open meaning longest spacing).

(3) Pick up rear side chains (1) (no cams) and place over top of tire.

(4) Tuck last crossmember (2) against bottom of tire with loose side chain (3) sticking out away from tire.

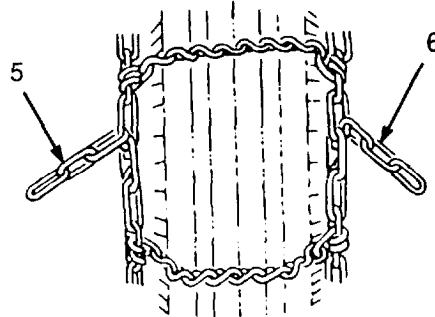
(5) Roll vehicle in direction of last crossmember (2) (approximately 1/4 tire revolution).



**2-45. OPERATE ON SNOW OR ICE (Con't).**

(6) Pull inside side chain (5) snug and hook into appropriate link to hold snug.

(7) Pull outside side chain (6) snug and hook.



**NOTE**

**Hooks must be even. Same number of loose links must appear on each side of chain. If not even, loosen outside hook and rehook both inside and outside hooks until they are even.**

(8) Close cams (4) by inserting key (7) in slot and rotate 180 degrees clockwise. Start with cam closet to side chain hook.

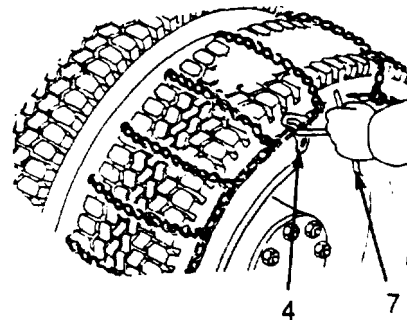
**NOTE**

**All four cams should not have to be locked for chain to be tight.**

(9) If additional tightening is required, tighten cam on opposite side of tire. Continue tightening cams as required.

(10) If all four cams are tight, loosen all four cams and resnug side chain at fastener hook until no more than three cams require adjustment.

(11) Drive approximately 1/2 mile and readjust chains as required.



---

**2-46. DRIVING WITH A DAMAGED TIRE (M917A1 AND M917A1 W/MCS).**

---

- a. Press RUN FLAT key on CTIS selector panel.
- b. After ten minutes, RUN FLAT light will flash and key may be pushed again to reactivate the feature.
- c. After the RUN FLAT feature has been activated, it may be shut off by pressing RUN FLAT key during the ten minute activation period.

## CHAPTER 3 MAINTENANCE INSTRUCTIONS

---

### Section I. LUBRICATION INSTRUCTIONS

---

#### 3-1. GENERAL.

---

- a. Lubrication instructions are in Appendix F of this manual.

#### NOTE

**For M917A1 and M917A1 w/MCS dump body lubrication Instructions, refer to TM 5-3605-264-14&P.**

- b. All lubrication instructions are mandatory.





## Section II. TROUBLESHOOTING PROCEDURES

Paragraph Number	Paragraph Number	Page Number
3-2.	General .....	3-3
3-3.	Explanation of Columns. ....	3-4
3-4.	Troubleshooting Symptom Index .....	3-4
Table 3-1.	Troubleshooting. ....	3-6

---

### 3-2. GENERAL.

---

**NOTE**

**Refer to TM 5-3805-264-14&P for M917A1 and M917A1 W/ MCS dump body troubleshooting.**

- a. This section provides information for identifying and correcting malfunctions which may develop while operating the M915 Family of Vehicles.
- b. The Troubleshooting Symptom index in paragraph 3-4 lists common malfunctions which may occur and refers you to the proper page in Table 3-1 for a troubleshooting procedure.
- c. If you are unsure of the location of an item mentioned in troubleshooting, refer to paragraph 1-10 or Chapter 2, Section I.
- d. Before performing troubleshooting, read and follow all safety instructions found in the Warning Summary at the front of this manual.
- e. This section cannot list all malfunctions that may occur, nor all tests or inspections and corrective actions. If a malfunction is not listed, or is not corrected by the listed corrective actions, notify your supervisor.
- f. When troubleshooting a malfunction:
  - (1) Locate the symptom or symptoms in paragraph 3-4 that best describe the malfunction.
  - (2) Turn to the page in Table 3-1 where the troubleshooting procedures for the malfunction in question are described. Headings at the top of each page show how each troubleshooting procedure is organized: MALFUNCTION, TEST OR INSPECTION (in step number order), and CORRECTIVE ACTION.
  - (3) Perform each step in the order listed until the malfunction is corrected. DO NOT perform any maintenance task unless the troubleshooting procedure tells you to do so.

---

**3-3. EXPLANATION OF COLUMNS.**

---

The columns in Table 3-1 are defined as follows:

- a. **MALFUNCTION.** A visual or operational indication that something is wrong with the equipment.
- b. **TEST OR INSPECTION.** A procedure to isolate the problem in a system or component.
- c. **CORRECTIVE ACTION.** A procedure to correct the problem.

---

**3-4. TROUBLESHOOTING SYMPTOM INDEX.**

---

	Troubleshooting Procedure Page
<b>AIR SYSTEM AND BRAKES</b>	
Air:	
Reservoir Pressure Low (Warning Light and Buzzer are ON).....	3-6
System Loses Pressure During Vehicle Operation or Low Air Pressure Warning Light and Buzzer Come On During Vehicle Operation .....	3-6
Trailer Brakes Will Not:	
Apply When Pedal or Hand Control on Steering Column is Used..	3-7
Release .....	3-7
 <b>CTIS (M917A1 and M917A1 wMCS)</b>	
CTIS Selector Panel indicates:	
Five Lights Flashing.. .....	3-7
Four Mode Lights Flashing .....	3-8
Two Mode Lights On Solid .....	3-8
 <b>DRIVELINE LOCKING SYSTEM</b>	
Driveline Will Not Disengage (Indicator Light Stays On) When Interaxle Lockout (All-Wheel Drive) Control Valve is Moved to UNLOCK (DISENGAGE) Position .....	
	3-9
 <b>ELECTRICAL SYSTEM</b>	
One or More Lighting Systems Not Working .....	3-9

---

**3-4. TROUBLESHOOTING SYMPTOM INDEX (Con't).**

---

	<b>Troubleshooting Procedure Page</b>
<b>ENGINE</b>	
Engine:	
Coolant Temperature Gage indicates Engine is Overheating .....	3-9
Crankes but Fails to Start .....	3-10
Does Not:	
Develop Full Power .....	3-11
Idle Properly .....	3-11
Excessive:	
Engine Oil Consumption .....	3-12
Exhaust Smoke (At Normal Engine Operating Speed) .....	3-12
Fails to Crank When Starter Button is Pressed.. ..	3-11
Starts but Misfires or Runs Rough After Proper Warmup Period..	3-12
Low or No Engine Oil Pressure .....	3-12
<b>POWER TAKE-OFF (PTO) (M916A1 AND M916A2)</b>	
PTO Does Not Engage .....	3-12
<b>STEERING</b>	
Hard Steering, Shimmy, or Wandering .....	3-12
Vehicle Steering Slow or Intermittent to Respond.. ..	3-13
<b>TRANSMISSION</b>	
Slow or Erratic Transmission Clutch Engagement .....	3-13
Transmission Fluid Temperature Gage Indicates Fluid is Overheating During Normal Operation .....	3-13
<b>WHEELS AND TIRES</b>	
Tires Worn Unevenly or Excessively .....	3-13
Vehicle Wanders or Pulls to One Side on Level Pavement.. ..	3-14
Wheel Wobbles .....	3-14
<b>WINCH (M916A1 and M916A2)</b>	
Winch:	
Drum Will Not Operate .....	3-15
Unusually Noisy When Operating .....	3-15

Table 3-1. Troubleshooting.

MALFUNCTION	TEST OR INSPECTION	CORRECTIVE ACTION
<i>AIR SYSTEM AND BRAKES</i>		
1. <b>AIR RESERVOIR PRESSURE LOW (WARNING LIGHT AND BUZZER ARE ON).</b>	<p>Step 1. Check whether air reservoir draincocks are closed. Close draincocks.</p> <p>Step 2. If vehicle is not coupled to a semitrailer, check position of trailer air supply control knob. Pull knob out (OFF).</p> <p>Step 3. Start engine (paragraph 2-14) and check for air leaks at air reservoirs, hoses, fittings, and intervehicular air hose connections. If air leaks are present, notify Unit Maintenance.</p> <p>Step 4. Perform semitrailer troubleshooting.</p>	
2. <b>AIR SYSTEM LOSES PRESSURE DURING VEHICLE OPERATION OR LOW AIR PRESSURE WARNING LIGHT AND BUZZER COME ON DURING VEHICLE OPERATION.</b>		

**NOTE**

**Any change in pressure on brake pedal will cause a change in air pressure reading.**

- Step 1. Ensure trailer air supply control knob is pulled out (OFF). Operate engine until warning light and buzzer go off and release parking brake. Stop engine and note reservoir pressure. Fully press and hold service brake pedal for two minutes. Have crewmember check for leaks. Reservoir pressure loss during two minute period should not exceed 5 psi (34 kPa).  
Close air reservoir draincocks. If leaks are present, notify Unit Maintenance.

**NOTE**

**Any change in pressure on brake pedal will cause a change in air pressure reading.**

- Step 2. Push trailer air supply control knob in (ON) to charge semitrailer air reservoirs and repeat step 1. Have crewmember check semitrailer for leaks. Pressure loss should not exceed 5 psi (34 kPa) in two minutes.

Table 3-1. Troubleshooting (Con't).

MALFUNCTION	TEST OR INSPECTION	CORRECTIVE ACTION
		If air leaks are present or reservoir pressure loss exceeds 5 psi (34 kPa) in two minutes, troubleshoot semitrailer.
<b>3. TRAILER BRAKES WILL NOT APPLY WHEN PEDAL OR HAND CONTROL ON STEERING COLUMN IS USED.</b>		Check intervehicular air hoses for proper connections to semitrailer. Connect air hoses.
<b>4. TRAILER BRAKES WILL NOT RELEASE.</b>		
	Step 1. Check position of trailer brake hand control. Move control to forward (OFF) position.	
	Step 2. Check position of trailer air supply control knob. Push knob in (ON).	
	Step 3. Check intervehicular air hoses for proper connections. Connect air hoses.	
	Step 4. Check vehicle air system for leaks. If leaks are found, notify Unit Maintenance. If leaks are not found and vehicle components are not damaged, troubleshoot semitrailer.	
	<i>CTIS (M917A1 AND M917A1 W/MCS)</i>	
<b>5. CTIS SELECTOR PANEL INDICATES FIVE LIGHTS FLASHING.</b>		
	Step 1. Check whether air reservoir draincocks are closed and position of trailer air supply control valve. Close air reservoir draincocks and pull valve out (OFF).	
	Step 2. Check condition of tires. If tire has a slow leak or minor puncture, select RUN FLAT on CTIS selector panel and continue operation. Change tire as soon as tactical situation permits.	
	Step 3. Check for broken or kinked air lines. If air lines are broken or kinked, notify Unit Maintenance	

Table 3-1. Troubleshooting (Con't).

MALFUNCTION	TEST OR INSPECTION	CORRECTIVE ACTION
Step 4.	Excessive air seal leakage during cold weather startup can occur. If tires are not damaged, continue operation.	Continue to operate vehicle. Condition should correct itself as seals warm-up. If condition does not correct itself, notify Unit Maintenance.
<b>6. CTIS SELECTOR PANEL INDICATES FOUR MODE LIGHTS FLASHING.</b>		
Step 1.	Check condition of tires.	If tire has a slow leak or minor puncture, select RUN FLAT on CTIS selector panel and continue operation. Change tire as soon as tactical situation permits.
Step 2.	Check whether air reservoir draincocks are closed and position of trailer air supply control valve.	Close air reservoir draincocks and pull valve out (OFF).
Step 3.	Check for broken or kinked air lines.	If air lines are broken or kinked, notify Unit Maintenance.
Step 4.	Excessive air seal leakage during cold weather startup can occur. If tires are not damaged, continue operation.	Continue to operate vehicle. Condition should correct itself as seals warm-up. If condition does not correct itself, notify Unit Maintenance.
<b>7. CTIS SELECTOR PANEL INDICATES TWO MODE LIGHTS ON SOLID.</b>		
Step 1.	Press any mode key and attempt a pressure change.	If pressure change is successful, continue mission.
Step 2.	Check whether air reservoir draincocks are closed and position of trailer air supply control valve.	Close air reservoir draincocks and pull valve out (OFF).
Step 3.	Check for broken or kinked air lines.	If air lines are broken or kinked, notify Unit Maintenance.

Table 3-1. Troubleshooting (Con't).

MALFUNCTION	TEST OR INSPECTION	CORRECTIVE ACTION
-------------	--------------------	-------------------

DRIVELINE LOCKING SYSTEM

8. **DRIVELINE WILL NOT DISENGAGE (INDICATOR LIGHT STAYS ON) WHEN INTERAXLE LOCKOUT (ALL-WHEEL DRIVE) CONTROL VALVE IS MOVED TO UNLOCK (DISENGAGE) POSITION.**

- Step 1. Ensure system has had enough time to disengage.  
 Leave interaxle lockout (all-wheel drive) in UNLOCKED (DISENGAGE) position and wait for light to go off.
- Step 2. If indicator light remains on, excessive driveline windup may have occurred. Back truck up slowly and check if indicator light goes off. If indicator light remains on, notify Unit Maintenance.

ELECTRICAL SYSTEM

9. **ONE OR MORE LIGHTING SYSTEMS NOT WORKING.**

- Step 1. Check position of switch(es). If vehicle is coupled to semitrailer and problem is with semitrailer lighting system, check intervehicular cable connection.  
 Place switch(es) in ON position and blackout light switch to NORMAL position. Connect intervehicular cable.
- Step 2. Perform semitrailer troubleshooting.

ENGINE

10. **ENGINE COOLANT TEMPERATURE GAGE INDICATES ENGINE IS OVERHEATING.**



**DO NOT remove radiator cap unless engine is cold. Remove radiator cap in two steps. First, place a thick cloth over cap and slowly turn cap left to first stop. Pause and allow pressure to escape. Turn cap further left until it can be removed. This is a pressurized cooling system and escaping steam, hot water, or coolant will cause serious burns.**

- Step 1. Check engine coolant level in radiator.  
 Add engine coolant as required (Appendix F).

Table 3-1. Troubleshooting (Con't).

MALFUNCTION	TEST OR INSPECTION	CORRECTIVE ACTION
	Step 2.	Check system for leaks. If leaks are found, notify Unit Maintenance.
	Step 3.	Check if radiator cooling fins are free of mud, snow, ice, or debris. Remove anything that blocks or impedes cooling fins.
	Step 4.	Check cooling fan drive belts for looseness. If belts are loose, notify Unit Maintenance.
	Step 5.	Check engine oil level. If engine oil is low, fill to correct level (Appendix F).
	Step 6.	Check transmission fluid level. If transmission fluid level is low, fill to correct level (Appendix F).

**11. ENGINE CRANKS BUT FAILS TO START.**



**Fuel tank cap may become hot during vehicle operation.  
Use hand protection when removing fuel cap.**

- Step 1. Check fuel gage with ignition switch in ON position.  
If empty, add fuel (paragraph 3-6).
- Step 2. Check air cleaner restriction indicator.  
If indicator is not clear, notify Unit Maintenance.
- Step 3. If operating M915A2 or M916A1 in temperature below 32°F (0°C), check that cold weather starting procedure was used.  
Perform cold weather starting procedure (paragraph 2-14).



Table 3-1. Troubleshooting (Con't).

MALFUNCTION	TEST OR INSPECTION	CORRECTIVE ACTION
-------------	--------------------	-------------------

**WARNING**

**Ether is highly flammable and explosive. DO NOT perform ether quick-start system checks or inspections while smoking or near fire, flame, or sparks. Failure to follow this warning may cause a fire and explosion, causing serious injury or death to personnel.**

- Step 4. If operating a vehicle with automatic ether injection system, check red indicator light on ether control relay (paragraph 2-8).  
If red light is on, notify Unit Maintenance.
  
- 12. ENGINE DOES NOT DEVELOP FULL POWER.**
  - Step 1. Check whether power take-off (PTO) is disengaged.  
Disengage PTO.
  - Step 2. Check air cleaner restriction indicator.  
If indicator is not clear, notify Unit Maintenance.
  
- 13. ENGINE DOES NOT IDLE PROPERLY.**
  - Step 1. Check air cleaner restriction indicator.  
If indicator is not clear, notify Unit Maintenance.
  - Step 2. If operating M915A2 or M916A1 in temperature below 32°F (0°C), check that cold weather starting procedure was used.  
Perform cold weather starting procedure (paragraph 2-14).
  
- 14. ENGINE FAILS TO CRANK WHEN STARTER BUTTON IS PRESSED.**
  - Step 1. Check position of ignition switch.  
Place ignition switch in ON position.
  - Step 2. Check position of transmission selector lever.  
Place transmission selector lever to Neutral (N) position.
  - Step 3. Check for dirty, loose, or broken battery cables.  
Clean dirty cables. Tighten loose connections at batteries, ground, and starter.  
If cable is broken, notify Unit Maintenance.

Table 3-1. Troubleshooting (Con't).

MALFUNCTION	TEST OR INSPECTION	CORRECTIVE ACTION
15. <b>ENGINE STARTS BUT MISFIRES OR RUNS ROUGH AFTER PROPER WARMUP PERIOD.</b>	Check air cleaner restriction indicator. If indicator is not clear, notify Unit Maintenance.	
16. <b>EXCESSIVE ENGINE OIL CONSUMPTION.</b>	Check for loose oil lines and oil leaks. If oil lines are loose or leaks are found, notify Unit Maintenance.	
17. <b>EXCESSIVE EXHAUST SMOKE (AT NORMAL ENGINE OPERATING SPEED).</b>	Step 1. Check air cleaner restriction indicator. If indicator is not clear, notify Unit Maintenance. Step 2. Check for water in fuel. Drain fuel/water separator (Table 2-1).	
18. <b>LOW OR NO ENGINE OIL PRESSURE.</b>	Check engine oil level. If engine oil is low, fill to correct level (Appendix F).	
POWER TAKE-OFF (PTO) (M916A1 AND M916A2)		
19. <b>PTO DOES NOT ENGAGE.</b>	Check position of PTO switch and that indicator light is ON. Place PTO switch in ON position and ensure indicator light comes ON.	
STEERING		
20. <b>HARD STEERING, SHIMMY, OR WANDERING.</b>		
<b>NOTE</b>		
	Check tire pressure when tires are cold.	
	Step 1. Check that tires are properly inflated. Inflate tires to proper pressure (Table 2-1).	

Table 3-1. Troubleshooting (Con't).

MALFUNCTION	TEST OR INSPECTION	CORRECTIVE ACTION
-------------	--------------------	-------------------

- Step 2. Check for loose lug nuts.  
Tighten loose lug nuts and notify Unit Maintenance to apply proper torque.
- Step 3. Check for worn, loose, or damaged parts on front axle or suspension. Check steering linkage, wheels, and vehicle frame for worn, loose, or damaged parts.  
If worn, loose, or damaged parts are found, notify Unit Maintenance.

**21. VEHICLE STEERING SLOW OR INTERMITTENT TO RESPOND.**

- Step 1. Check power steering fluid level.  
If power steering fluid is low, fill to correct level (Appendix F).
- Step 2. Check for proper operation of power steering.  
With vehicle at halt, turn steering wheel in either direction until steer limit is reached. Hold steering wheel in position for five seconds. Turn steering wheel in other direction until steering limit is reached. Repeat cycling a number of times.

---

TRANSMISSION

**22. SLOW OR ERRATIC TRANSMISSION CLUTCH ENGAGEMENT.**

- Check transmission fluid level.  
If transmission fluid is low, fill to correct level (Appendix F).

**23. TRANSMISSION FLUID TEMPERATURE GAGE INDICATES FLUID IS OVERHEATING DURING NORMAL OPERATION.**

- Step 1. Check transmission fluid level.  
If transmission fluid is low, fill to correct level (Appendix F).
- Step 2. Check transmission fluid dipstick for discoloration that would indicate water/coolant in fluid.  
If dipstick is discolored, notify Unit Maintenance.

---

WHEELS AND TIRES

**24. TIRES WORN UNEVENLY OR EXCESSIVELY.**

- Step 1. Check tires for proper pressure.  
Inflate tires to proper pressure (Table 2-1).

**Table 3-1. Troubleshooting (Con't).**

<b>MALFUNCTION</b>	<b>TEST OR INSPECTION</b>	<b>CORRECTIVE ACTION</b>
	Step 2.	<p>Check for bent wheel rims.</p> <p>If rim is bent, replace wheel and tire assembly. Notify Unit Maintenance to apply proper torque.</p>
	Step 3.	<p>Check for loose lugs nuts and worn, loose, or damaged suspension components.</p> <p>Tighten loose lug nuts and notify Unit Maintenance to apply proper torque.</p> <p>If suspension components are worn, loose, or damaged, notify Unit Maintenance.</p>
<b>25. VEHICLE WANDERS OR PULLS TO ONE SIDE ON LEVEL PAVEMENT.</b>		
	Step 1.	<p>Check tires for proper pressure.</p> <p>Inflate tires to proper pressure (Table 2-1).</p>
	Step 2.	<p>Check that tires are proper size and type.</p> <p>If one tire is mismatched and spare matches, replace mismatched tire with spare. If one or more tires are mismatched, notify Unit Maintenance.</p>
	Step 3.	<p>Check for loose or damaged steering gear/linkage.</p> <p>If steering gear/linkage is loose or damaged, notify Unit Maintenance.</p>
<b>26. WHEEL WOBBLES.</b>		
	Step 1.	<p>Check for loose or missing lug nuts.</p> <p>Tighten loose lug nuts and notify Unit Maintenance to apply proper torque,</p> <p>If lug nuts are missing, notify Unit Maintenance.</p>
	Step 2.	<p>Check for bent wheel rims.</p> <p>If rim is bent, replace wheel and tire assembly. Notify Unit Maintenance to apply proper torque.</p>
	Step 3.	<p>Check for loose, worn, or damaged steering and suspension components.</p> <p>If steering or suspension components are damaged, notify Unit Maintenance.</p>

Table 3-1. Troubleshooting (Con't).

MALFUNCTION	TEST OR INSPECTION	CORRECTIVE ACTION
WINCH (M916A1 AND M916A2)		
27. WINCH DRUM WILL NOT OPERATE.	Step 1. Check position of PTO switch and that PTO indicator light is ON.	Place PTO switch in ON position and ensure PTO indicator light is lit.
	Step 2. Check position of engine speed switch on winch control console.	Place engine speed switch to HIGH position.
	Step 3. Check if winch drum is free from any debris that would prevent it from turning.	Remove any debris that blocks winch drum.

**WARNING**

**DO NOT remove fill cap when hydraulic fluid is hot. Hydraulic tank is pressurized to 5 psi (34 kPa). Remove cap slowly to prevent burns.**

Step 4. Check hydraulic fluid level.

If hydraulic fluid is low, fill to correct level (Appendix F).

28. WINCH UNUSUALLY NOISY WHEN OPERATING.

**WARNING**

**Always wear heavy gloves when handling winch cable. Never allow cable to run through hands; frayed cable can cut you. Never operate winch with less than four turns of cable on drum. Keep cable coils tight and close together on drum while winching. Failure to follow this warning may result in injury to personnel.**

Check that cable is not twisted, tangled, or causing drum to bind.

Pay out or take up cable and straighten.



### Section III. MAINTENANCE PROCEDURES

Paragraph Number	Paragraph Title	Page Number
3-5.	Cleaning Vehicle . . . . .	3-17
3-6.	Refueling . . . . .	3-18
3-7.	Manual Tire Inflation . . . . .	3-19
3-8.	Operation of Spare Wheel and Tire Assembly Carrier . . . . .	3-21
3-9.	Wheel and Tire Assembly Replacement (All Except M917A1 and M917A1 w/MCS) . . . . .	3-23
3-10.	Front Wheel and Tire Assembly Replacement (M917A1 and M917A1 w/MCS) . . . . .	3-28
3-11.	Rear Wheel and Tire Assembly Replacement (M917A1 and M917A1 w/MCS) . . . . .	3-32
3-12.	Battery Box Cover Replacement. . . . .	3-38

#### 3-5. CLEANING VEHICLE.

**WARNING**

Compressed air used for cleaning or drying purposes, or for clearing restrictions, should never exceed 30 psi (207 kPa). Wear protective clothing (goggles/shield, gloves, etc.) and use caution to avoid injury to personnel.

**CAUTION**

**DO NOT use high pressure water to clean inside of cab or engine compartment. Damage to electrical system may result.**

a. **Exterior.**

- (1) Never wipe dirt off when vehicle is dry.
- (2) Never wash vehicle in direct sunlight or if vehicle exterior is hot to touch.
- (3) Wash vehicle often using cold or lukewarm water (never use hot water or any strong detergent). Do not use abrasives to remove mud and dirt from your vehicle.

---

### 3-5. CLEANING VEHICLE (Con't).

---

(4) While cleaning vehicle, look closely for evidence of rust or corrosion, bare metal, or other exterior damage. If any problems are found, notify Unit Maintenance to treat affected areas.

b. **Interior.**

(1) Remove loose dust and dirt from cab interior components.

(2) Clean upholstery and seat belts using a mild solution of warm water and soap (never use solvents or abrasives). Wipe all washed areas dry.

---

### 3-6. REFUELING.

---

**WARNING**

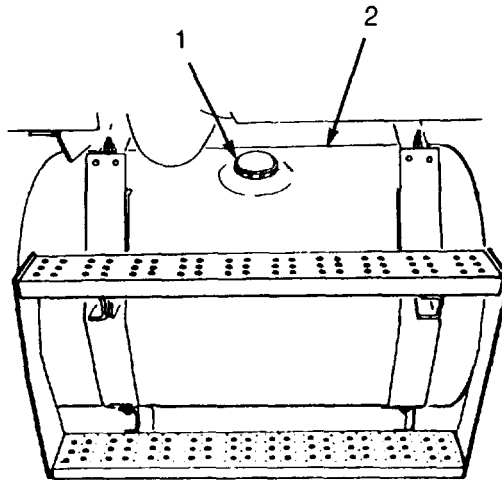
- Fuel tank cap may become hot during vehicle operation. Use hand protection when removing fuel cap.
- **DO NOT** smoke or permit any open flame in area of truck while you are servicing diesel fuel system. Be sure hose nozzle is grounded against filler tube during refueling to prevent static electricity. Failure to follow this warning may result in injury to personnel or equipment damage.
- Place portable fire extinguisher within reach prior to refueling.
- **DO NOT** overfill fuel tank.
- **If fuel starts foaming from fuel tank, stop immediately to avoid fuel spillage.**
- **Failure to follow this warning could result in injury to personnel.**
  - a. Shut down engine (paragraph 2-20).
  - b. Wipe off dirt on and around fuel filler cap (1).
  - c. Remove filler cap (1) by rotating cap counterclockwise.
  - d. Fill tank (2) to holes [approximately 3 in. (7.6 cm)] in filler neck.
  - e. Install filler cap (1) by rotating cap clockwise as far as it will go.



---

**3-6. REFUELING (Con't).**

---

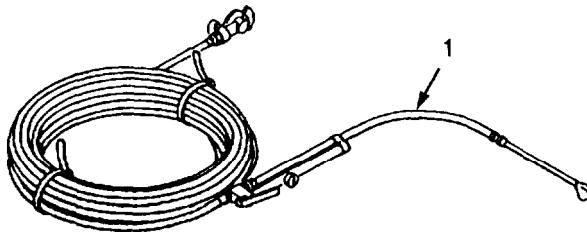


---

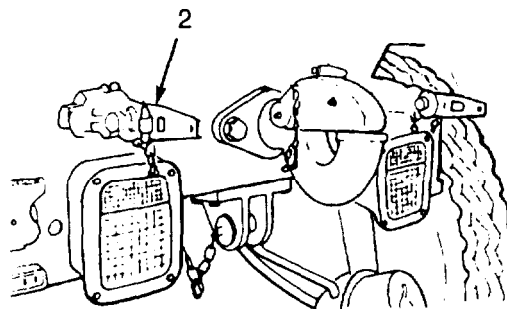
**3-7. MANUAL TIRE INFLATION.**

---

- a. Remove pneumatic hose (1) with gauge from BII storage box.



- b. Connect pneumatic hose (1) to emergency gladhand (red) (2) on left rear of vehicle.



- c. Start engine (paragraph 2-14) and push in (ON) trailer air supply control valve.

---

**3-7. MANUAL TIRE INFLATION (Con't).**

---

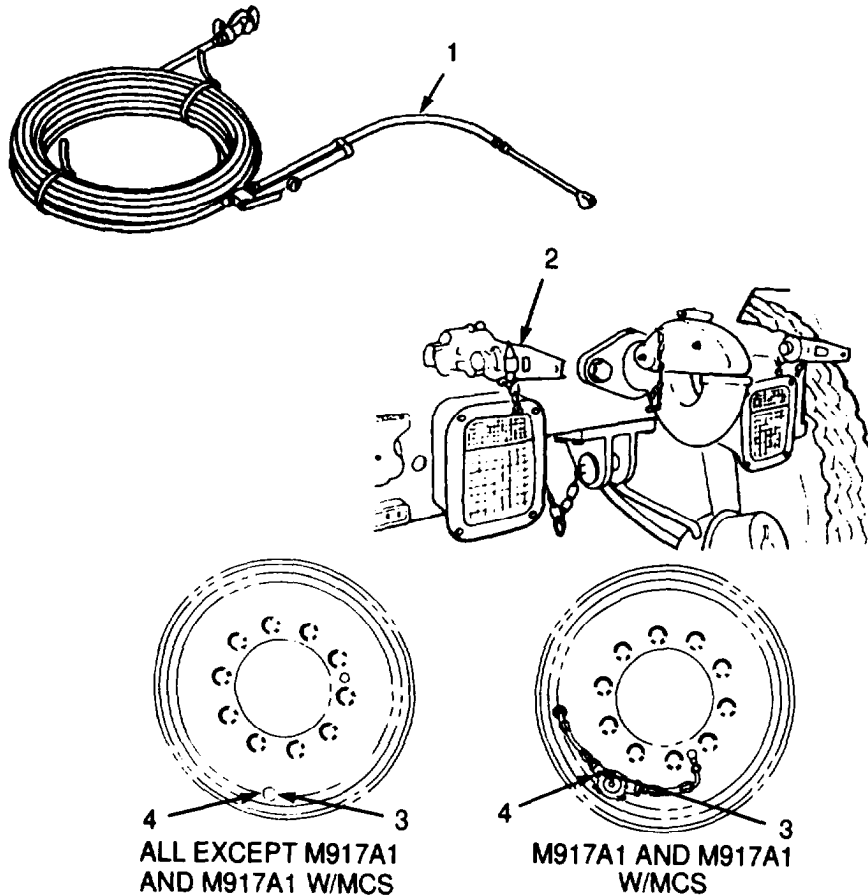
**NOTE**

**For M917A1 and M917A1 w/MCS, valve stem is located on CTIS wheel valve.**

- d. Remove valve stem cap (3) and connect pneumatic hose (1) to valve stem (4).
- e. Add air until desired pressure is reached.
- f. Remove pneumatic hose (1) from valve stem (4) and install valve stem cap (3).

Pull out (OFF) trailer air supply control valve and shut down engine (paragraph 2-20).

- h. Disconnect pneumatic hose (1) from emergency gladhand (2) and return to stowage.



**3-8. OPERATION OF SPARE WHEEL AND TIRE ASSEMBLY CARRIER.**

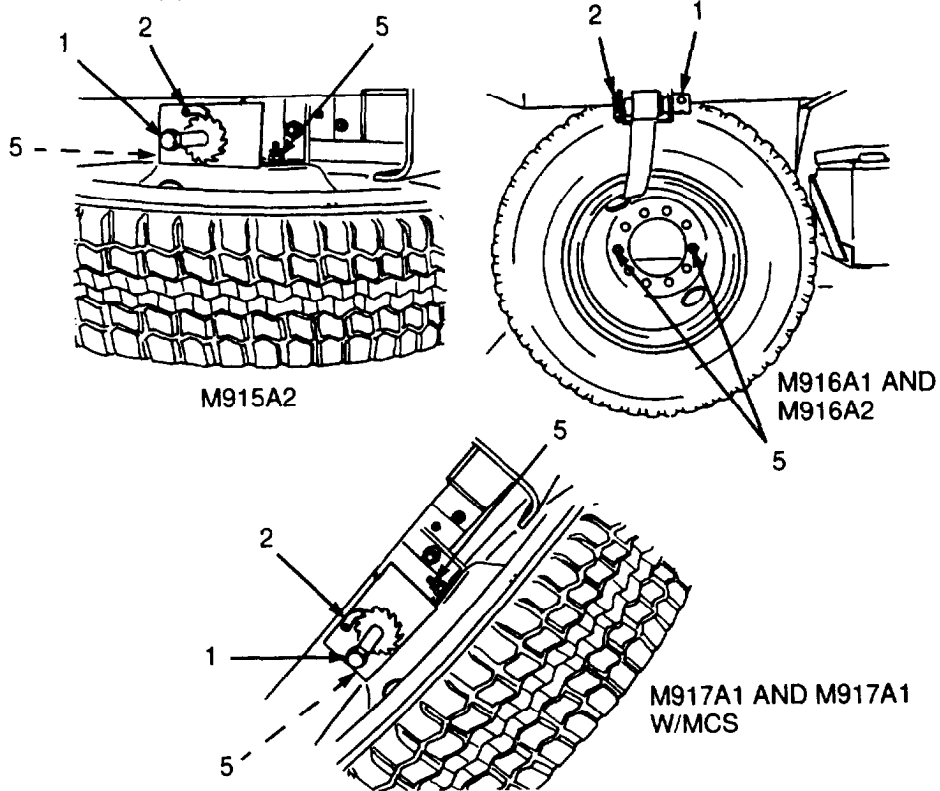
a. **Remove Spare Wheel and Tire Assembly from Carrier.**

- (1) Ensure pawl (2) engages gear shaft (1) and remove two nuts (5).
- (2) Turn gear shaft (1) clockwise slightly and disengage pawl (2) from gear shaft. Swing pawl (2) out of way.

**WARNING**

Use caution when lifting or handling wheel and tire assembly. It is heavy and could cause injury if improperly lifted or if it falls on you.

- (3) Slowly rotate gear shaft (1) counterclockwise one notch.



**3-8. OPERATION OF SPARE WHEEL AND TIRE ASSEMBLY CARRIER (Con't).**

(4) For M915A2, M917A1, and M917A1 w/MCS, support spare wheel and tire assembly (6) and remove wheel clamp plate (7). For M916A1 and M916A2, support spare wheel and tire assembly (6) and disengage D-ring (4) on upper end of support strap (8).

(5) Repeat steps (2) and (3) until spare wheel and tire assembly is lowered to ground.

**b. Install Spare Wheel and Tire Assembly on Carrier.**

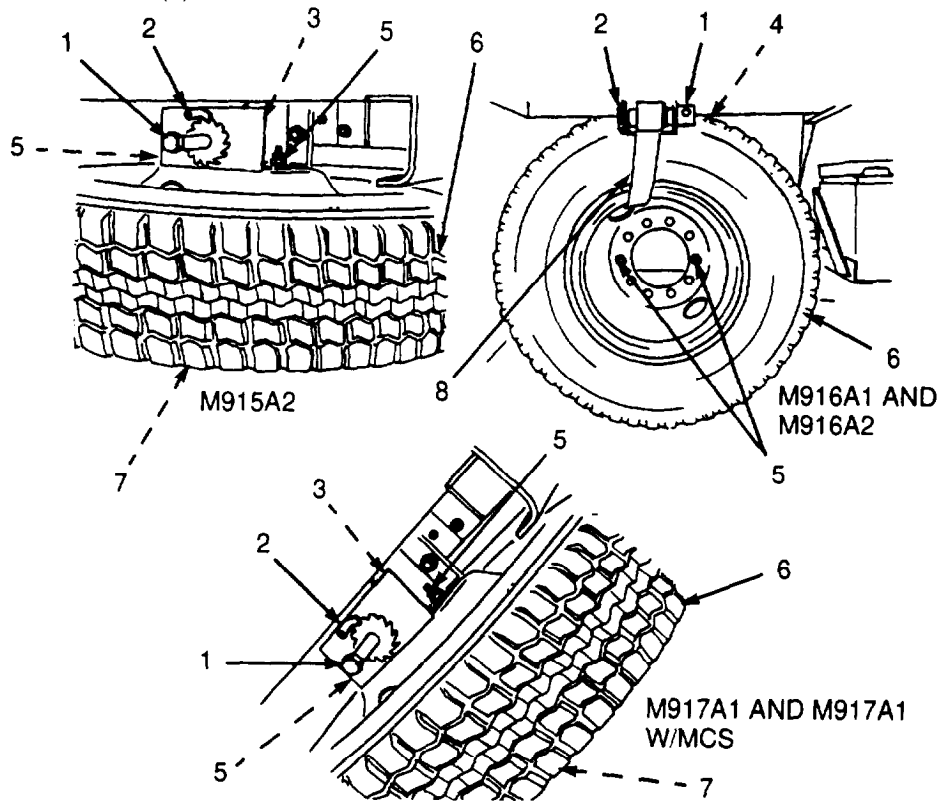
(1) For M915A2, M917A1, and M917A1 w/MCS, secure hoist cable (3) by inserting wheel clamp plate (7) through wheel opening.

(2) For M916A1 and M916A2, wrap support strap (8) around spare wheel and tire assembly (6) and attach D-ring (4) to hook on frame rail.

(3) Turn gear shaft (1) clockwise until spare wheel and tire assembly (6) is raised to stowed position.

(4) Engage pawl (2) on gear shaft (1).

(5) Install two nuts (5).



---

**3-9. WHEEL AND TIRE ASSEMBLY REPLACEMENT (ALL EXCEPT M917A1 AND M917A1 W/MCS).**

---

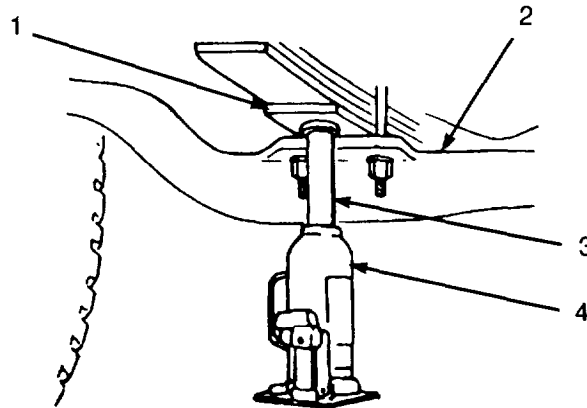
**NOTE**

**When changing tires, DO NOT substitute type or size tire unless all tires on the vehicle can be converted. Keep all tires the same size and type.**

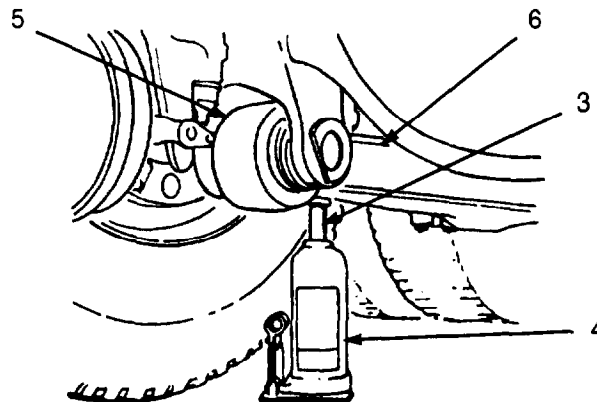
a. **Placement of Jack.**

(1) **M915A2.**

(a) For front tire replacement, place jack (4) so jack ram (3) is under first small leaf spring (1) just forward of axle (2).



(b) For rear tire replacement, place jack (4) so jack ram (3) is under equalizing beam (6) inboard of equalizing beam end adapter (5).



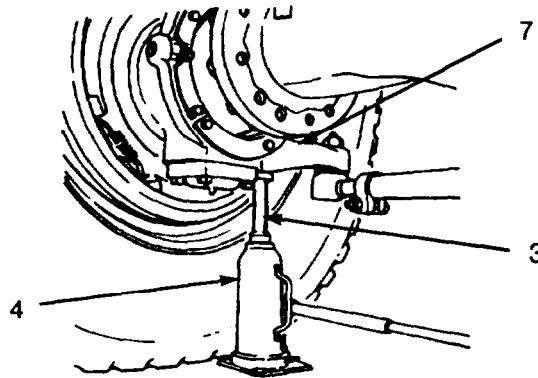
---

**3-9. WHEEL AND TIRE ASSEMBLY REPLACEMENT (ALL EXCEPT M917A1 AND M917A1 W/MCS (Con't).**

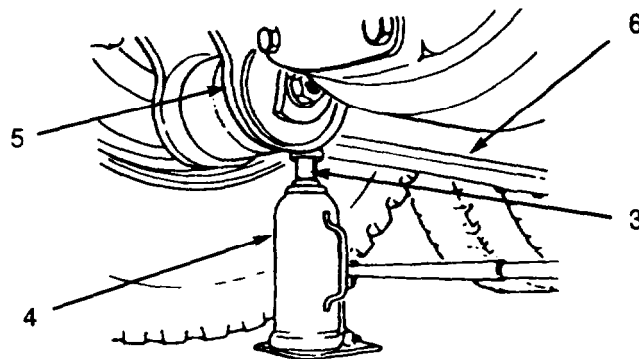
---

(2) **M916A1 and M916A2.**

(a) For front tire replacement, place jack (4) so jack ram (3) is under front axle steering arm (7).



(b) For rear tire replacement, place jack (4) so jack ram (3) is under equalizing beam (6) inboard of equalizing beam end adapter (5).



b. **Remove Wheel and Tire Assembly.**

- (1) Block wheels.
- (2) Remove spare wheel and tire assembly from carrier (paragraph 3-8).

---

**3-9. WHEEL AND TIRE ASSEMBLY REPLACEMENT (ALL EXCEPT M917A1 AND M917A1 W/MCS (Con't)).**

---

**NOTE**

- **If replacing inner rear tire, loosen both outer and inner wheel nuts.**
- **Wheel nuts on left side of vehicle are left hand threads (turn right to loosen, turn left to tighten). Wheel nuts on right side of vehicle are right hand threads (turn left to loosen, turn right to tighten).**
  - (3) Remove wheel nuts on wheel to be removed.
  - (4) Place jack in position (step a).

**WARNING**

**Hydraulic jack is intended only for lifting truck, not for supporting vehicle to perform maintenance. Do not get under truck after it is raised unless it is properly supported with blocks or jackstands. Failure to observe this warning may result in death or injury to personnel.**

- (5) Raise jack until tire(s) clears ground.

**WARNING**

**Use caution when lifting or handling wheel and tire assembly. It is heavy and could cause injury if improperly lifted or if it falls on you.**

- (6) For front or outer rear tire, remove wheel nuts and wheel and tire assembly.
- (7) If replacing inner rear tire, remove wheel nuts and wheel and tire assembly.

c. **Install Wheel and Tire Assembly.**

- (1) Manually inflate spare tire to proper pressure (paragraph 3-6).

---

**3-9. WHEEL AND TIRE ASSEMBLY REPLACEMENT (ALL EXCEPT M917A1 AND M917A1 W/MCS (Con't)).**

---

**WARNING**

Use caution when lifting or handling wheel and tire assembly. It is heavy and could cause injury if improperly lifted or if it falls on you.

**NOTE**

- **Wheel nuts on left side of vehicle are left hand threads (turn right to loosen, turn left to tighten). Wheel nuts on right side of vehicle are right hand threads (turn left to loosen, turn right to tighten).**
- **Valve stems on inner and outer rear tires should be positioned 180° apart.**
  - (2) If replacing inner rear tire, position wheel and tire assembly on wheel hub and install and handtighten wheel nuts.
  - (3) For front or outer rear tire, position wheel and tire assembly on wheel hub and install and handtighten wheel nuts.
  - (4) Lower and remove jack.



---

### 3-9. WHEEL AND TIRE ASSEMBLY REPLACEMENT (ALL EXCEPT M917A1 AND M917A1 W/MCS (Con't)).

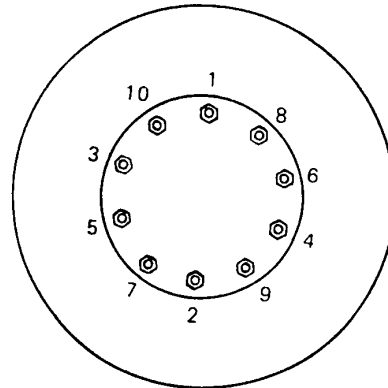
---

**WARNING**

Whenever inner and/or outer wheel lug nuts require tightening or a wheel has been removed and replaced, lug nuts must be torqued to the required torque. Failure to follow this warning may result in serious injury to personnel and damage to equipment.

- Tighten wheel nuts with wheel wrench. After 25 miles (40 km), retighten wheel nuts. Within next 75 miles (121 km), have Unit Maintenance torque wheel nuts to proper torque.
- Tightening pattern is identical for all wheel assemblies.

(5) For front or outer rear tire, tighten wheel nuts according to tightening pattern.



WHEEL NUT TIGHTENING PATTERN

(6) If replacing inner rear tire, alternately tighten inner wheel nuts by removing outer wheel nut according to tightening pattern and tighten inner wheel nut. After tightening inner wheel nut, reinstall outer wheel nut and tighten according to tightening pattern.

(7) Notify Unit Maintenance as soon as possible to apply proper torque.

(8) Stow defective tire in spare wheel and tire carrier (paragraph 3-8) and have it replaced or repaired as soon as possible.

(9) Remove wheel blocks.

---

### 3-10. FRONT WHEEL AND TIRE ASSEMBLY REPLACEMENT (M917A1 AND M917A1 W/MCS).

---

a. Remove Front Wheel and Tire Assembly.

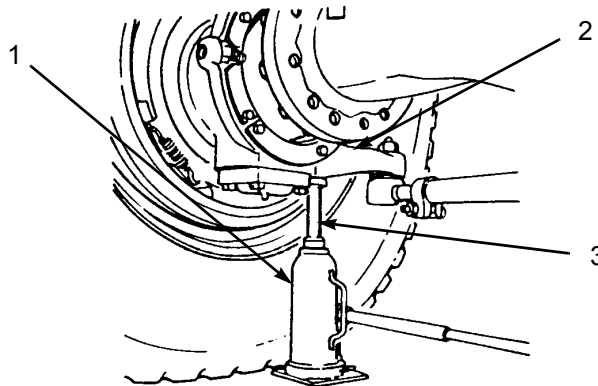
**NOTE**

- When changing tires, do not substitute type or tire size unless all tires can be converted.

(1) Stop engine (paragraph 2-20) and drain vehicle air system (Table 2-1).

(2) Block wheels.

(3) Position jack (1) so jack ram (3) is under front steering axle (2).



**WARNING**

Always wear eye protection and drain all air from wet tank before disconnecting CTIS air lines, hoses or fittings. Residual air in tire(s) and air line(s) will be expelled even though tire(s) is flat. Failure to follow this warning could cause serious eye injury.

(4) Disconnect hose (6) from elbow (5).

(5) Disconnect connector (7) from wheel valve (8).

(6) Remove elbow (5) from hub air port (4).

(7) Remove spare wheel and tire from carrier (paragraph 3-8).

---

### 3-10. FRONT WHEEL AND TIRE ASSEMBLY REPLACEMENT (M917A1 AND M917A1 W/MCS) (Con't).

---

#### NOTE

Wheel nuts on left side of vehicle are left hand threads (turn right to loosen, turn left to tighten). Wheel nuts on right side of vehicle are right hand threads (turn left to loosen, turn right to tighten).

- (8) Loosen wheel nuts on wheel to be removed.

**WARNING**

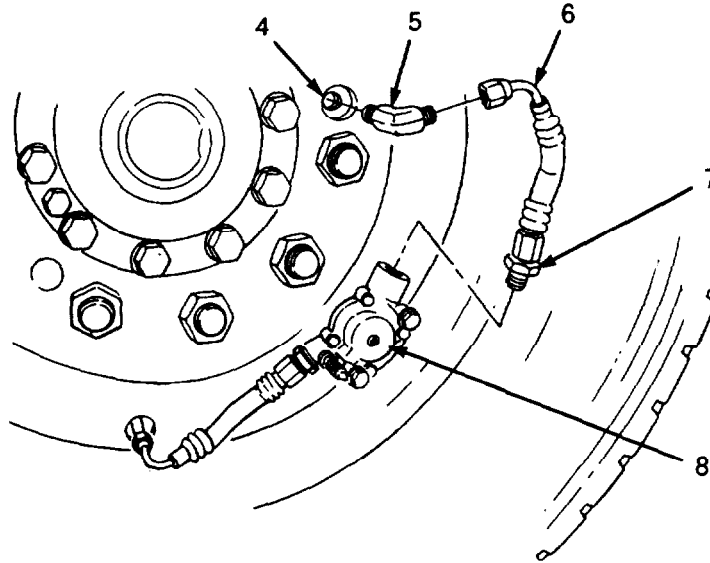
Hydraulic jack is intended only for lifting truck, not for supporting vehicle to perform maintenance. Do not get under truck after it is raised unless it is properly supported with blocks or jackstands. Failure to observe this warning may result in death or injury to personnel.

- (9) Raise jack until tire clears ground.

**WARNING**

Use caution when lifting or handling wheel and tire assembly. It is heavy and could cause injury if improperly lifted or if it fails on you.

- (10) Remove wheel nuts and wheel and tire assembly.



---

### 3-10. FRONT WHEEL AND TIRE ASSEMBLY REPLACEMENT (M917A1 AND M917A1 W/MCS) (Con't).

---

b. Install Front Wheel and Tire Assembly.

**WARNING**

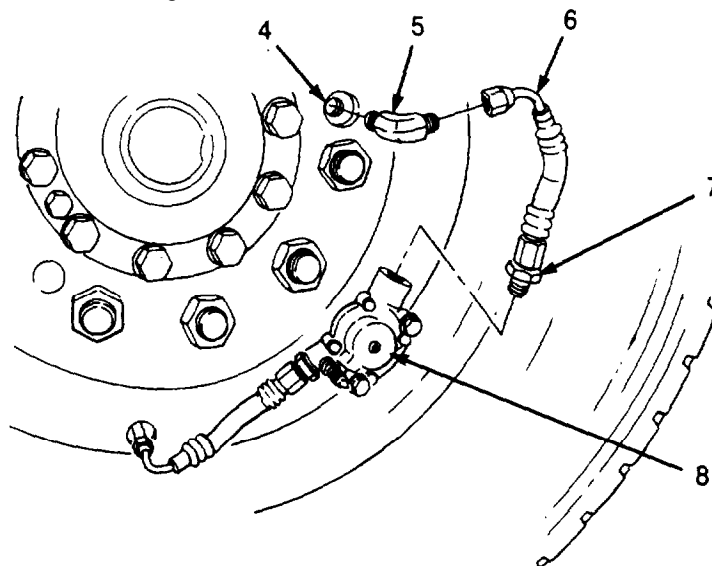
Use caution when lifting or handling wheel and tire assembly. It is heavy and could cause injury if improperly lifted or if it falls on you.

- (1) Position wheel and tire assembly on wheel hub ensuring hole in wheel aligns with hub air port (4).

**NOTE**

Wheel nuts on left side of vehicle are left hand threads (turn right to loosen, turn left to tighten). Wheel nuts on right side of vehicle are right hand threads (turn left to loosen, turn right to tighten).

- (2) Install and handtighten wheel nuts.
- (3) Lower and remove jack.
- (4) Connect elbow (5) to hub air port (4) with open elbow port perpendicular to outer edge of wheel.



---

**3-10. FRONT WHEEL AND TIRE ASSEMBLY REPLACEMENT (M917A1 AND M917A1 W/MCS) (Con't).**

---

(5) Remove protective plug from wheel valve (8) and install on wheel valve of defective tire.

(6) Connect connector (7) to wheel valve (8).

**NOTE**

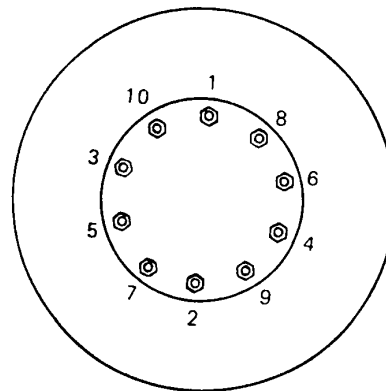
**Ensure hose is not kinked after connecting to elbow. Rotate elbow, if necessary.**

(7) Connect hose (6) to elbow (5).

**NOTE**

- **Tighten wheel nuts with wheel wrench. After 25 miles (40 km), retighten wheel nuts. Within next 75 miles (121 km), have Unit Maintenance torque wheel nuts to proper torque.**
- **Tightening pattern is identical for all wheel assemblies.**

(8) Tighten wheel nuts according to wheel tightening pattern.



WHEEL NUT TIGHTENING PATTERN

(9) Stow defective tire in spare wheel and tire carrier (paragraph 3-8) and have it replaced or repaired as soon as possible.

(10) Notify Unit Maintenance as soon as possible to apply proper torque.

(11) Inflate tire to desired pressure using CTIS (paragraph 2-17) or manual inflation procedure (paragraph 3-7).

(12) Remove wheel blocks.

---

### 3-11. REAR WHEEL AND TIRE ASSEMBLY REPLACEMENT (M917A1 AND M917A1 W/MCS).

---

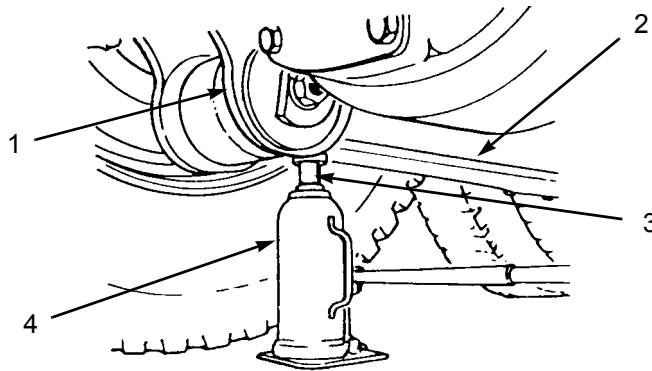
#### NOTE

- When changing tires, **DO NOT** substitute type or tire size unless all tires can be converted.

a. **Remove Rear Wheel and Tire Assembly.**

(1) Stop engine (paragraph 2-20) and drain vehicle air system (Table 2-1).

(2) Position jack (4) so jack ram (3) is under equalizing beam (2) inward of equalizing beam end adapter (1)



(3) Remove valve stem cap (12) from wheel valve (10) and deflate both tires by pressing on valve stem core (13).

**WARNING**

**Always wear eye protection and drain all air from wet tank before disconnecting CTIS air lines, hoses or fittings. Residual air in tire(s) and air line(s) will be expelled even though tire(s) is flat. Failure to follow this warning could cause serious eye injury.**

(4) Disconnect hose (8) from hub air port connector (6) and remove hub air port connector from hub air port (5).

(5) Disconnect hose (19) from outer wheel valve stem (16).

---

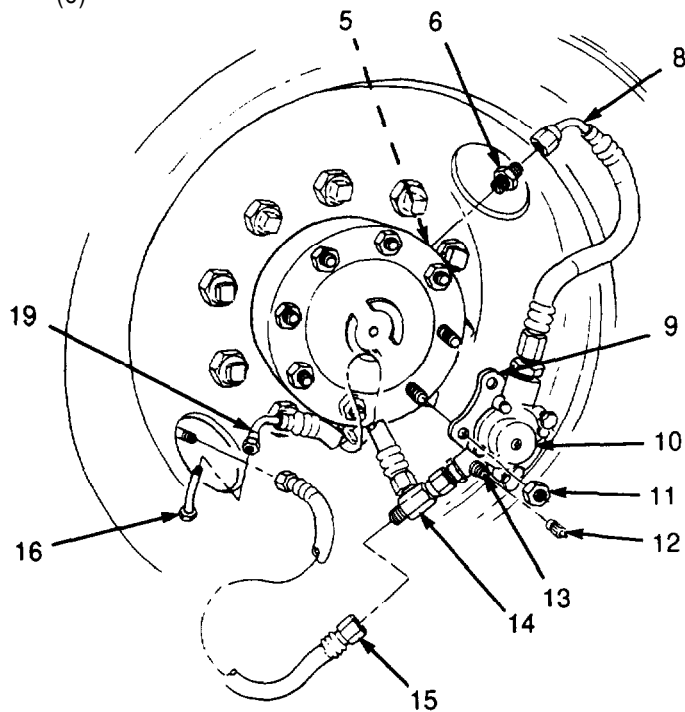
**3-11. REAR WHEEL AND TIRE ASSEMBLY REPLACEMENT (M917A1 AND M917A1 W/MCS) (Con't).**

---

(6) Disconnect inner wheel valve stem hose (15) from tee connector (14).

(7) Remove two hub nuts (11) and bracket (9) with wheel valve (10) and hoses attached.

(8) Block wheels.



**NOTE**

- **Wheel nuts on left side of vehicle are left hand threads (turn right to loosen, turn left to tighten). Wheel nuts on right side of vehicle are right hand threads (turn left to loosen, turn right to tighten).**
- **If replacing inner rear tire, loosen both outer and inner wheel nuts.**

(9) Loosen, but do not remove, wheel nuts.

---

**3-11. REAR WHEEL AND TIRE ASSEMBLY REPLACEMENT  
(M917A1 AND M917A1 W/MCS) (Con't).**

---

**WARNING**

Hydraulic jack is intended only for lifting truck, not for supporting vehicle to perform maintenance. Do not get under truck after it is raised unless it is properly supported with blocks or jackstands. Failure to observe this warning may result in death or injury to personnel.

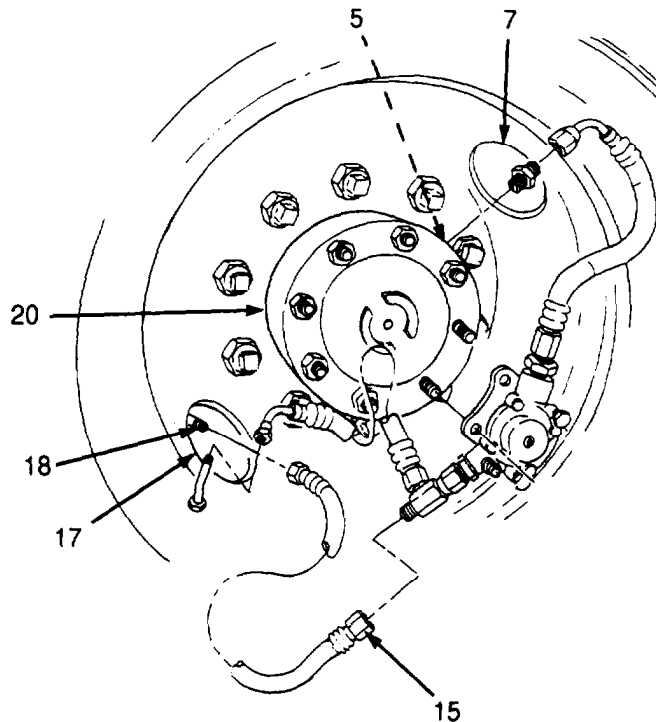
(10) Raise jack until tires clear ground. Use caution when lifting or handling wheel and tire assembly. It is heavy and could cause injury if improperly lifted or if it falls on you.

(11) Remove outer tire wheel nuts and wheel and tire assembly.

(12) If replacing inner rear tire, remove spacer, wheel nuts, and wheel and tire assembly. Remove hose (15) from valve stem (18).

b. **Install Rear Wheel and Tire Assembly.**

(1) Obtain a deflated replacement wheel and tire assembly ensuring valve stem cap and valve stem core are removed.





---

**3-11. REAR WHEEL AND TIRE ASSEMBLY REPLACEMENT  
(M917A1 AND M917A1 W/MCS) (Con't).**

---

- stem (18). (2) If replacing inner tire, connect hose (15) to inner wheel valve
- position. (3) Rotate wheel hub (20) until hub air port (5) is at 12 o'clock

**WARNING**

**Use caution when lifting or handling wheel and tire assembly. It is heavy and could cause injury if improperly lifted or if it falls on you.**

**NOTE**

**Wheel nuts on left side of vehicle are left hand threads (turn right to loosen, turn left to tighten). Wheel nuts on right side of vehicle are right hand threads (turn left to loosen, turn right to tighten).**

- (4) If replacing inner tire, position wheel and tire assembly on wheel hub (20) with hand hold (7) (not containing valve stem) aligned with hub air port (5). Install wheel nuts and handtighten.
- (5) Install spacer.
- (6) Position outer wheel and tire assembly on wheel hub (20) with hand hold (7) (not containing valve stem) aligned with hub air port (5). Install wheel nuts and handtighten.
- hand hold (17). (7) Route inner wheel valve stem hose (15) through outer wheel
- (8) Lower and remove jack.

---

**3-11. REAR WHEEL AND TIRE ASSEMBLY REPLACEMENT (M917A1 AND M917A1 W/MCS) (Con't).**

---

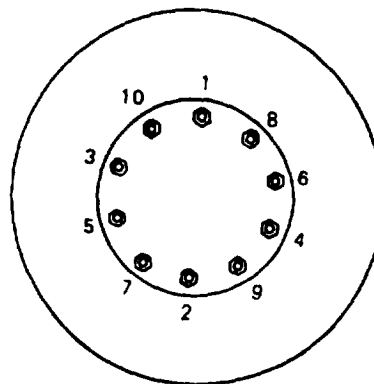
**WARNING**

Whenever inner and/or outer wheel lug nuts require tightening or a wheel has been removed and replaced, lug nuts must be torqued to the required torque. Failure to follow this warning may result in serious injury to personnel and damage to equipment.

**NOTE**

Tightening pattern is identical for all wheel assemblies.

(9) Have Unit Maintenance apply proper torque to wheel nuts.



**WHEEL NUT TIGHTENING PATTERN**

(10) Remove two hub nuts (11) at 4 and 5 o'clock position.

(11) Position bracket (9) with wheel valve (10) and hoses attached on wheel hub studs.

(12) Install two hub nuts (11) and have Unit Maintenance apply proper torque.

(13) Connect inner wheel valve stem hose (15) to tee connector (14).

(14) Connect hose (19) to outer wheel valve stem (16).

(15) Connect hub port connector (6) to hub air port (5).

(16) Connect hose (8) to hub port connector (6).

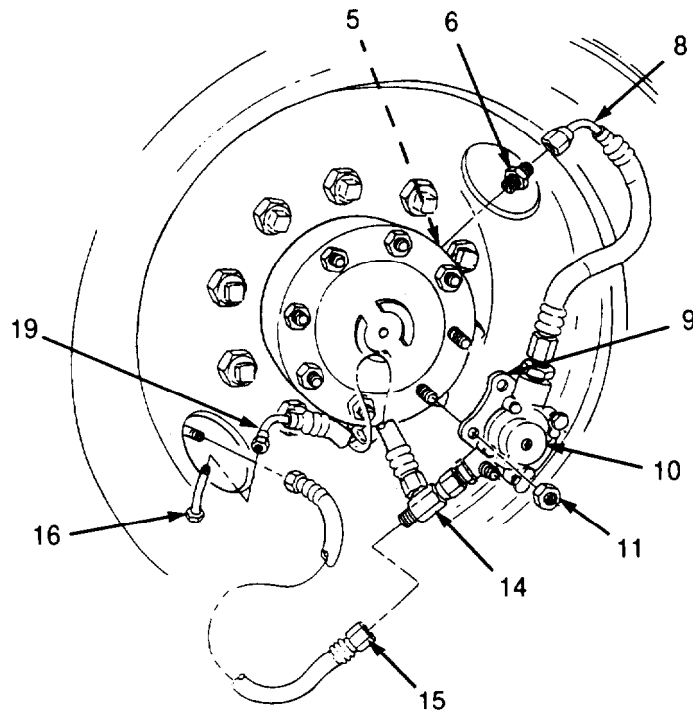
(17) Remove wheel blocks.

(18) Inflate tires using CTIS (paragraph 2-17) or manual tire inflation procedure (paragraph 3-8).

---

**3-11. REAR WHEEL AND TIRE ASSEMBLY REPLACEMENT  
(M917A1 AND M917A1 W/MCS) (Con't).**

---



---

**3-12. BATTERY BOX COVER REPLACEMENT.**

---

**WARNING**

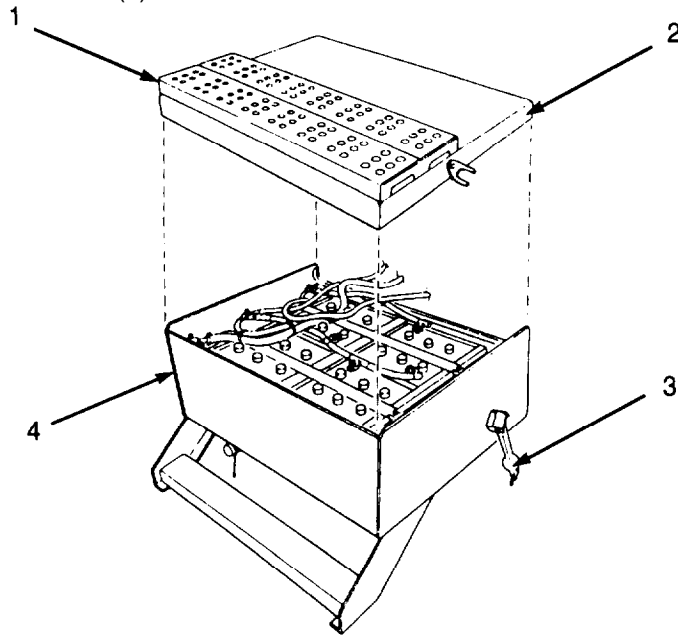
- To avoid eye injury, eye protection is required when working around batteries. Do not smoke, use open flame, make sparks, or create other ignition sources around batteries. If a battery is giving off gases, it can explode and cause injury to personnel. Remove all jewelry such as rings, ID tags, watches, and bracelets. If jewelry or a tool contacts a battery terminal, a direct short will result in instant heating, damage to equipment, and injury to personnel.
- Sulfuric acid contained in batteries can cause serious burns. If battery corrosion or electrolyte makes contact with skin, eyes, or clothing, take immediate action to stop the corrosive burning effects. Failure to follow these procedures may result in death or serious injury to personnel.
  - a. **Eyes.** Flush with cold water for no less than 15 minutes and seek medical attention immediately.
  - b. **Skin.** Flush with large amounts of cold water until all acid is removed. Seek medical attention as required.
  - c. **Internal.** If corrosion or electrolyte is ingested, drink large amounts of water or milk. Follow with milk of magnesia, beaten egg, or vegetable oil. Seek medical attention immediately.
  - d. **Clothing/Equipment.** Wash area with large amounts of cold water. Neutralize acid with baking soda or household ammonia.
- a. Unfasten two latches (3) and slide battery box cover (2) outboard from battery box (4).

---

**3-12. BATTERY BOX COVER REPLACEMENT (Con't).**

---

- b. Slide battery box cover (2) on battery box (4) with step (1) outboard and fasten two latches (3).





## APPENDIX A REFERENCES

---

### A-1. SCOPE.

---

This appendix lists all forms, field manuals, technical manuals, and other publications referenced in this manual and which apply to the operation of the M915 Family of Vehicles.

---

### A-2. PUBLICATION INDEXES.

---

The following indexes should be consulted frequently for latest changes or revisions and for new publications relating to material covered in this technical manual.

Consolidated Index of Army Publications and Blank Forms .....	DA Pam 25-30
Functional User's Manual for the Army Maintenance Management System .....	DA Pam 738-750
U.S. Army Equipment Index of Modification Work Orders .....	DA Pam 750-10

---

### A-3. FORMS.

---

Refer to DA Pam 738-750, *The Army Maintenance Management System (TAMMS)*, for instructions on the use of maintenance forms.

Equipment Inspection and Maintenance Worksheet.....	DA Form 2404
Product Quality Deficiency Report .....	SF Form 368
Recommended Changes to Equipment Technical Publications.....	DA Form 2028-2
Recommended Changes to Publications and Blank Forms.....	DA Form 2028

---

### A-4. FIELD MANUALS.

---

Basic Cold Weather Manual .....	FM 31-70
Camouflage.....	FM 5-20
Cold Weather Operations .....	FM 9-207
Desert Operations.....	FM 90-3
Driver Selection/Training.....	FM 21-300
First Aid Manual .....	FM 4-25.11
Manual for the Wheeled Vehicle Driver.....	FM 21-305
NBC Contamination Avoidance .....	FM 3-3

---

**A-4. FIELD MANUALS (Con't).**

---

NBC Decontamination .....FM 3-5  
NBC Protection.....FM 3-4  
Northern Operations.....FM 31-71  
Rigging .....FM 5-725  
Vehicle Recovery Operations .....FM 20-22

---

**A-5. TECHNICAL MANUALS.**

---

Batteries ..... TM 9-6140-200-14  
Care, Maintenance, Repair, and Inspection of Pneumatic  
Tires and Inner Tubes ..... TM 9-2620-200-14  
Destruction of Army Materiel to Prevent Enemy Use ..... TM 750-244-6  
Operator's, Unit, Direct Support Maintenance Manual  
with RPSTL for M917A1 and M917A1 w/MCS Dump  
Truck Body..... TM 5-3805-264-14&P  
Operator's, Unit, Direct Support, and General Support  
Maintenance Manual (Including Repair Parts and Special  
Tools List) for Semitrailer, Flatbed: Breakbulk/Container  
Transporter, 34 Ton M872/M872A1/M872A2/M872A3..... TM 9-2330-359-14&P  
Operator's, Unit, Direct Support, and General Support  
Maintenance Manual (Including Repair Parts and Special  
Tools List) for Semitrailer, Lowbed: 25 Ton, 4 Wheel,  
M172/M172A1 ..... TM 9-2330-211-14&P  
Operator's, Unit, Direct Support, and General Support  
Maintenance Manual (Including Repair Parts and Special  
Tools List) for Semitrailer, Lowbed: 40 Ton Construction  
Equipment Transporter, M870/M870A1 ..... TM 5-2330-360-14&P/  
TM 5-2330-378-14&P  
Operator's, Unit, Direct Support, and General Support  
Maintenance Manual (Including Repair Parts and Special  
Tools List) for Semitrailer, Tactical, Dual Purpose  
Breakbulk/Container Transporter, 22 ½ Ton  
M871/M871A1 ..... TM 9-2330-359-14&P  
Operator's, Unit, Direct Support, and General Support  
Maintenance Manual (Including Repair Parts and Special  
Tools List) for Semitrailer, Tank, Fuel, 7500 Gallon,  
M1062..... TM 9-2330-384-14&P



---

**A-5. TECHNICAL MANUALS (Con't).**

---

Operator's, Unit, Direct Support, and General Support  
Maintenance Manual with RPSTL for 6,000 Gallon  
Semitrailer Water Distributor Model WD6S ..... TM 5-3825-225-14&P

Operator's, Unit, Direct Support, and General Support  
Maintenance Manual with RPSTL for 6,000 Gallon  
Water Distributor Model 60 PRS ..... TM 5-3825-255-14&P

Principles of Automotive Vehicles ..... TM 9-8000

---

**A-6. TECHNICAL BULLETINS.**

---

Rust Proofing Procedures for Truck, Utility ..... TB 43-0213

Warranty ..... TB 9-2320-363-15

---

**A-7. OTHER PUBLICATIONS.**

---

Abbreviations and Acronyms ..... ASME Y14.38-1999

Army Medical Department Expendable/Durable Items ..... CTA 8-100

Expendable/Durable Items (Except Medical, Class V,  
Repair Parts, and Heraldic Items) ..... CTA 50-970

Prevention of Motor Vehicle Accidents ..... AR 385-55



## APPENDIX B

# COMPONENTS OF END ITEM AND BASIC ISSUE ITEMS LISTS

---

### Section I. INTRODUCTION

---

#### B-1. SCOPE.

---

This appendix lists Components of End Item and Basic Issue Items for the M915 Family of Vehicles to help you inventory items required for safe and efficient operation.

---

#### B-2. GENERAL.

---

The Components of End Item (COEI) and Basic Issue Items (BII) Lists are divided into the following sections:

a. **Section II. Components of End Item.** This listing is for informational purposes only and is not authority to requisition replacements. These items are part of the end item, but are removed and separately packaged for transportation or shipment. As part of the end item, these items must be with the end item whenever it is issued or transferred between property accounts. Illustrations are furnished to assist you in identifying the items.

b. **Section III. Basic Issue Items.** These are the minimum essential items required to place the truck in operation, to operate it, and to perform emergency repairs. Although shipped separately packaged, BII must be with the truck during operation and whenever it is transferred between property accounts. The illustrations will assist you with hard-to-identify items. This manual is your authority to request/requisition replacement BII, based on TOE/MTOE authorization of end item.

---

#### B-3. EXPLANATION OF COLUMNS.

---

Below is an explanation of columns found in the tabular listings:

a. **Column (1) Illustration Number (Illus Number).** This column indicates the number of the illustration that shows the item.

b. **Column (2) National Stock Number.** Indicates the National Stock Number (NSN) assigned to the item and will be used for requisitioning purposes.

---

**B-3. EXPLANATION OF COLUMNS (Con't).**

---

c. **Column (3) - Description and Usable On Code.** Indicates the Federal item name and, if required, a minimum description in parentheses to identify and locate the item. The entry for each item ends with the Commercial and Government Entity Code (CAGEC) in parentheses followed by the part number. Usable On Code indicates the vehicle to which the item is assigned. Usable on codes for the M915 Family of Vehicles are:

<b><u>Usable On Code</u></b>	<b><u>Model</u></b>
5A2	M915A2
6A1	M916A1
6A2	M916A2
7A1	M917A1
7E1	M917A1 w/MCS

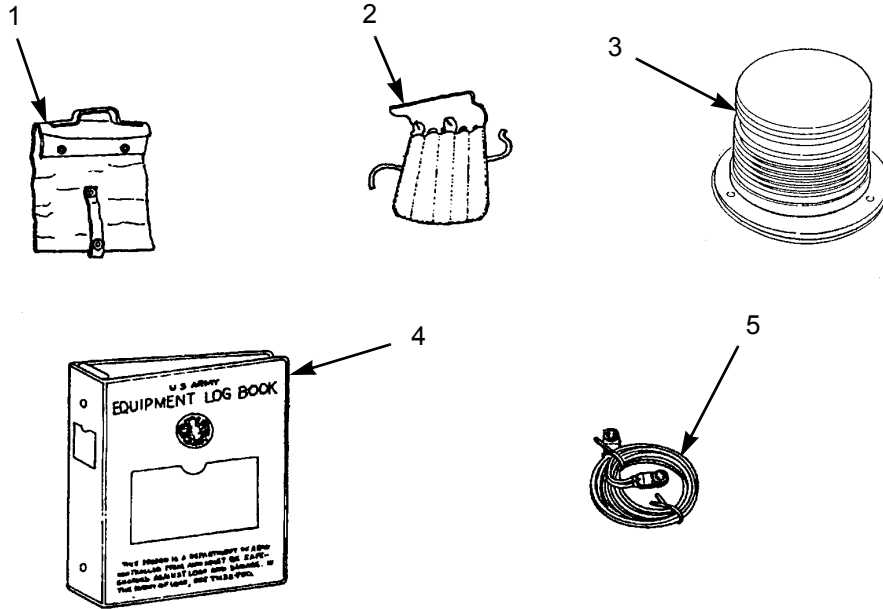
d. **Column (4) - Unit of Issue (U/I).** Indicates how the item is issued for the National Stock Number shown in Column (2).

e. **Column (5) Quantity Required (Qty/Red).** Indicates the quantity of the item authorized to be used with the equipment.

**Section II. COMPONENTS OF END ITEM**

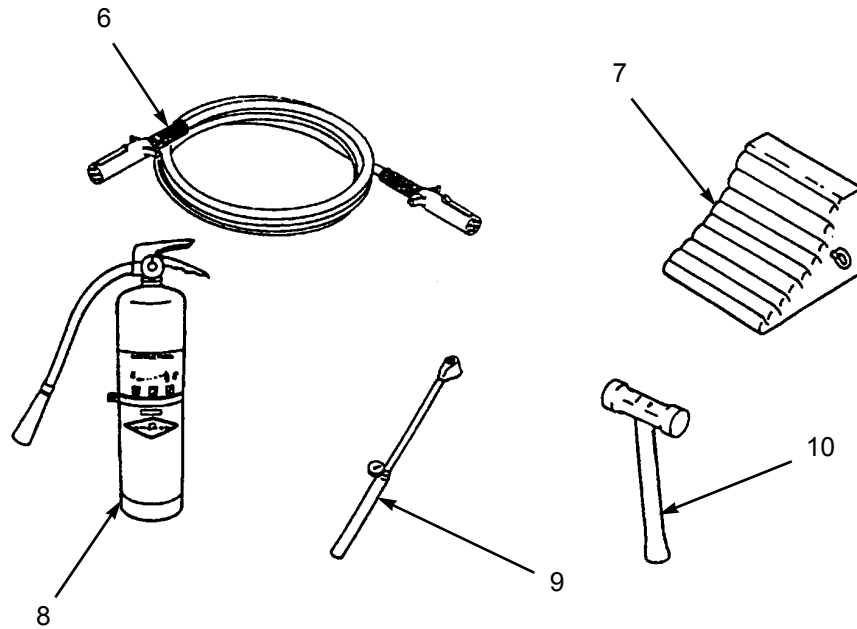
There are currently no COEI assigned.

**Section III. BASIC ISSUE ITEMS**



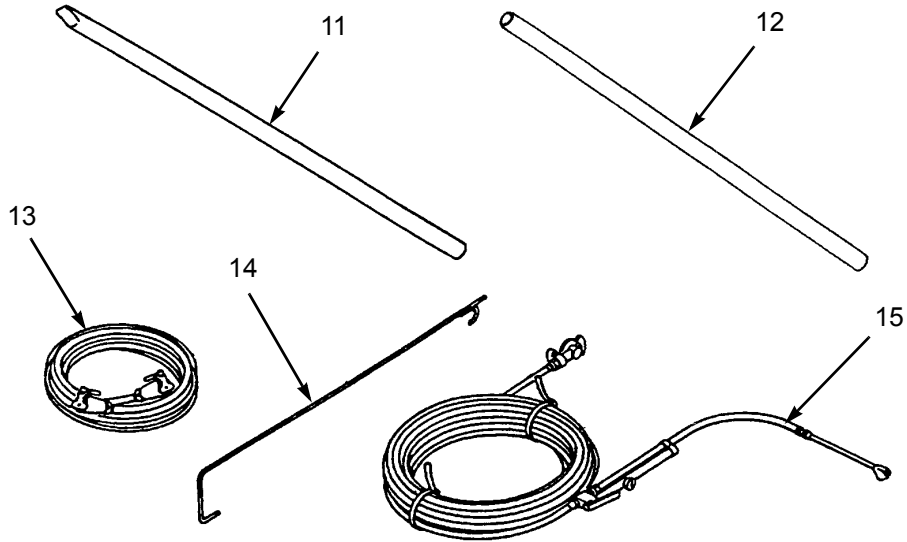
(1) Illus Number	(2) National Stock Number	(3) Description (CAGEC) Part Number	(4) Usable on Code	(5) U/I	(6) Qty Rqd
1	2540-00-670-2459	Bag, Pamphlet (In cab glove box) (19207) 11676920		EA	1
2	5140-00-356-8471	Bag, Tool (in BII storage box) (19204) 7541507		EA	1
3	6220-01-495-2851	Beacon, Warning Light Kit 12 volt (66654) SY22011H-A		EA	1
4	7510-00-889-3494	Binder, Looseleaf (19207) 11677003		EA	1
5	6150-01-022-6004	Cable Assy, Power NATO (in BII storage box) (19207) 11682336-1		EA	1

**Section III. BASIC ISSUE ITEMS (Con't)**



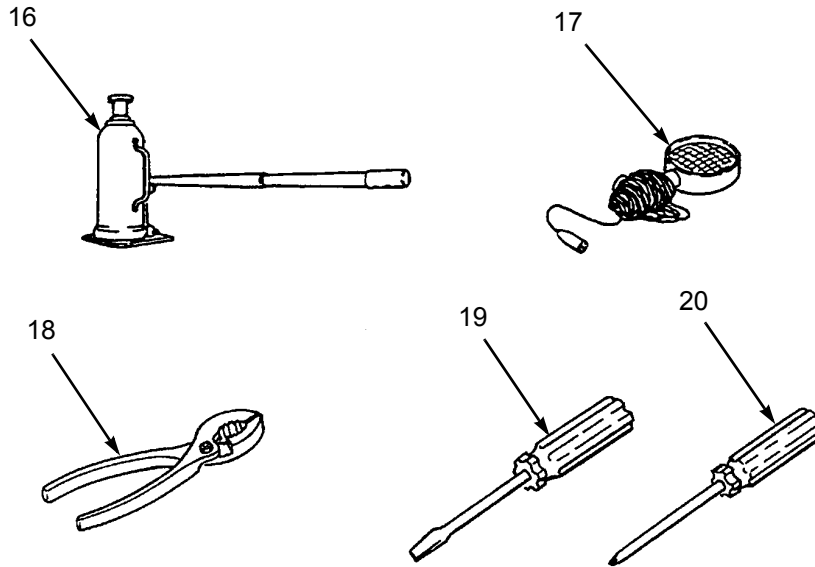
(1) Illus Number	(2) National Stock Number	(3) Description (CAGEC) Part Number	(4) Usable on Code	(5) U/I	(6) Qty Rqd
6	6150-01-478-6510	Cable Assy, 12 volt, Tractor-Tri, 12 ft. (in BII storage box) (64678) PHM-42FL40-144		EA	1
7	2540-00-678-3469	Chock, Wheel (in BII storage box) (58536) A-A-52475-1		EA	2
8	4210-01-338-6064	Extinguisher, Fire (on cab floor) (54905) 447		EA	1
9	4910-01-003-9599	Gauge, Tire (in cab glove box) (19207) 7974576-1		EA	1
10	5120-00-242-3915	Hammer, 2 lb (in BII storage box) (80063) SMC133095		EA	1

**Section III. BASIC ISSUE ITEMS (Con't)**



(1) Illus Number	(2) National Stock Number	(3) Description (CAGEC) Part Number	(4) Usable On Code	(5) U/I	(6) Qty Rqd
11	5120-00-243-2419	Handle, 30 in. long (in BII storage box) (71282)44201		EA	1
12	5120-01-084-3298	Handle, Wrench (in BII storage box) (34623) 967556		EA	1
13	6150-00-772-8814	Harness Assy, 12 ft., 24 volt (in BII storage box) (19207) 7728814	5A2 6A1 6A2	EA	1
14	5340-01-328-444	Hook (n side of 5th wheel) (74410) XA-0756	6A1 6A2	EA	1
15	4910-01-407-2953	Hose, Pneumatic, (Tire Inflation) with Gauge, 40 ft. (in BII storage box) (19207) 11677140-7		EA	1

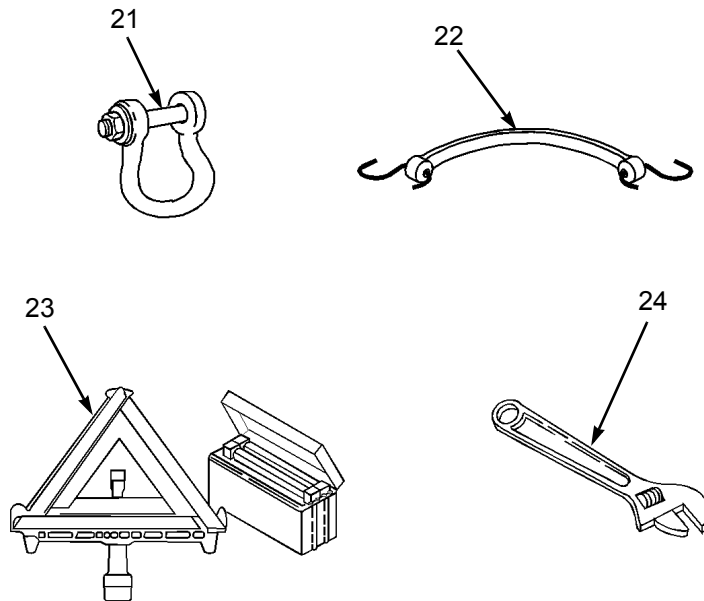
**Section III. BASIC ISSUE ITEMS (Con't)**



(1) Illus Number	(2) National Stock Number	(3) Description (CAGEC) Part Number	(4) Usable On Code	(5) U/I	(6) Qty Rqd
16	5120-01-146-8096	Jack Hydraulic, 20 Ton w/ Handle (in BII storage box) (63704) 28961		EA	1
17	6220-01-327-3225	Lamp, Work, Portable 12 volt, 25 ft. Cord (in BII storage box) (78422) 1401152		EA	2
18	5120-00-181-6819	Pliers, Combination Gen- eral Purpose (in BII storage box) (72368) J26		EA	1
19	5120-00-227-7356	Screwdriver, Flat Tip (in BII storage box) (64067) 5120-00-227-7356		EA	1
20	5120-00-234-8913	Screwdriver, Crosstip (in BII storage box) (75347) BD122		EA	1



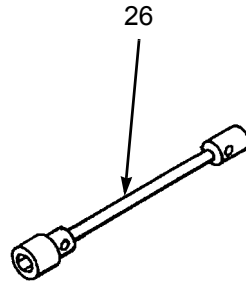
**Section III. BASIC ISSUE ITEMS (Con't)**



336-037

(1) Illus Number	(2) National Stock Number	(3) Description (CAGEC) Part Number	(4) Usable On Code	(5) U/I	(6) Qty Rqd
21	4030-01-187-0964	Shackles, Towing (in BII storage box) (19207) 12328579		EA	6
22	3990-01-327-1278	Tie Down, Hood, Molded Rubber (in BII storage box) (0C1E6) CR15A		EA	2
23	9905-00-148-9546	Triangle, Folding-Reflective (in BII storage box) (19207) 11669000		EA	1
24	5120-00-240-5328	Wrench, Adjustable, 8 in. long (in BII storage box) (19207) 11655778-3		EA	1

**Section III. BASIC ISSUE ITEMS (Con't)**



(1) Illus Number	(2) National Stock Number	(3) Description (CAGEC) Part Number	(4) Usable On Code	(5) U/I	(6) Qty Rqd
26	5120-00-293-1289	Wrench, Lug (in BII storage box) (03683) 18806		EA	1

## APPENDIX C ADDITIONAL AUTHORIZATION LIST

---

### Section I. INTRODUCTION

---

#### C-1. SCOPE.

---

This appendix lists additional items that you are authorized for the support of the M915 Family of Vehicles.

---

#### C-2. GENERAL.

---

This list identifies items that do not have to accompany the truck and that do not have to be turned in with it. These items are authorized to you by CTA, MTOE TDA, or JTA.

---

#### C-3. EXPLANATION OF LISTING.

---

National Stock Numbers, descriptions, and quantities are provided to help you identify and request the additional items you require to support this equipment. If the item required differs for different models of this equipment, see the "Usable On Code" column for the applicable model or models. Usable On Codes for the M915 Family of Vehicles are:

<u>Usable On Code</u>	<u>Model</u>
5A2	M915A2
6A1	M916A1
6A2	M916A2
7A1	M917A1
7E1	M917A1 w/MCS

**Section II. ADDITIONAL AUTHORIZATION LIST**

(1) National Stock Number	(2) Description CAGEC & Part Number	(3) Usable On Code	(4) Qty Auth
6130-01-449-7594	Analyzer, Charger, Battery (09GZ5) VC-5	ea	1
5110-00-293-2336	Axe, Single Bit, 4-16-HD wt, 35.5- 36.5 in. long (19207) 6150925	ea	1
5510-00-491-0306	Block, Jack Support Wood, 4X8X9 in. (19207) CPR103023-1	ea	1
5510-00-491-0307	Block, Jack Support Wood, 7X8X9 in. (19207) CPR103023-2	ea	1
	Chains, Tire (80535) 2245	5A2	pr 2
2540-01-396-1914	Chains, Tire (80535) 002-2749	6A1 6A2 7A1 7E1	pr 2
5340-00-545-2337	Clevis Part of Tow Bar 2540-00-378-2012 (19207) 8724449	ea	2
8415-00-268-7859	Gloves, Welders (58536) A-A-50022	6A1 6A2	pr 1
5120-00-288-6574	Handle, Mattock, 35.5-36.5 in. long (19207) 11677021	ea	1
2540-01-345-8896	Kit, Arctic Engine Heater (64678) 681 830 10 K1	ea	1
2540-01-345-8898	Kit, Arctic Personnel Heater (64678) 681 830 12 K1	ea	1
2540-01-347-6249	Kit, Arctic Personnel Heater (64678) 681 830 11 K1	ea	1
6545-00-922-1200	Kit, First Aid (19207) 11677011	ea	1
4230-01-133-4124	Kit, M13 Apparatus (81361) E5-51-527	ea	1

**Section III. ADDITIONAL AUTHORIZATION LIST (Con't)**

(1) National Stock Number	(2) Description CAGEC & Part Number	Usable On Code	(3) U/M	(4) Qty Auth
5340-01-345-4676	Kit,M13 Decontamination Mounting (64678) 681 899 01 K0		ea	1
005-01-345-8880	Kit, Rifle Mounting (64678) 681 816 00 K0	5A2 6A1 6A2	ea	1
005-01-439-9229	Kit, Rifle Mounting (64678) 681 816 00 K2	7A1 7E1	ea	1
5340-00-158-3805	Padlock (96906) MS35647-10	5A2 6A1 6A2	ea	7
5340-00-158-3805	Padlock (96906) MS35647-10	7A1 7E1	ea	3
5120-00-243-2395	Pick, Mattock, 5 lb Without Handle (19207) 11677022		ea	1
5315-00-539-9174	Pin Part of Tow Bar 2540-00-378-2012 (19207) 10929861		ea	1
5315-00-350-4326	Pin,Locking Part of Tow Bar 2540-00-378-2012 (19207) 5213744		ea	1
5120-00-293-3336	Shovel, Hand, Rd-Pt, D-Hdl, Short Size 2 (19207) 11655784	5A2 6A1 6A2	ea	1
2540-01-267-2912	Tow Bar, Medium Duty (19207) 12322663		ea	1



## APPENDIX D EXPENDABLE AND DURABLE ITEMS LIST

---

### Section I. INTRODUCTION

---

#### D-1. SCOPE.

---

This appendix lists expendable and durable items you will need to operate and maintain the M915 Family of Vehicles. This listing is for informational purposes only and is not authority to requisition the listed items. These items are authorized to you by CTA 50-970, Expendable/Durable Items (Except Medical, Class V, Repair Parts, and Heraldic Items), or CTA 8-100, Army Medical Department Expendable/Durable Items.

---

#### D-2. EXPLANATION OF COLUMNS.

---

a. **Column (1) - Item Number.** This number is assigned to the entry in the listing and is referenced in the narrative instructions to identify the item [e.g., Use dry cleaning solvent (Item 17, Appendix D)].

b. **Column (2) Level.** This column identifies the lowest level of maintenance that requires the listed item.

C - Operator/Crew

c. **Column (3) National Stock Number.** This is the National Stock Number assigned to the item which you can use to requisition it.

d. **Column (4) - Item Name, Description, Commercial and Government Entity Code (CAGEC), and Part Number.** This provides the other information you need to identify the item.

e. **Column (5) - Unit of Measure (U/M) Unit of Issue (U/I).** This column shows the physical measurement or count of an item, such as gallon, dozen, gross, etc.

**Section II. EXPENDABLE AND DURABLE ITEMS LIST**

(1) Item Number	(2) Level	(3) National Stock Number	(4) Description (CAGEC) Part Number	(5) U/M U/I
1	C	6850-00-174-1806	ANTIFREEZE: Arctic Grade (81349) MIL-A-11755 55 Gallon Drum	gl
2	C	6850-00-181-7929 6850-00-181-7933 6850-00-181-7940	ANTIFREEZE: Permanent Ethylene Glycol, Inhibited, Heavy Duty (81349) MIL-A-46153 1 Gallon Can 5 Gallon Can 55 Gallon Drum	gl gl gl
3	C	6850-00-926-2275	Cleaning Compound, Windshield (81348), O-C-1901	pt
4	C	7930-00-282-9699	DETERGENT: General Purpose, Liquid (81348) 7930-00-282-9699 1 Gallon Can	gl
5	C	9140-00-286-5295 9140-00-286-5296 9140-00-286-5297	FUEL DIESEL: DF-2 Grade (81348) VVF800GRADEDF2RE 5 Gallon Can 55 Gallon Drum, 16 Gage 55 Gallon Drum, 18 Gage	gl gl gl
6	C	9140-00-286-5286 9140-00-286-5287 9140-00-286-5288 9140-00-286-5289	FUEL: Diesel, Winter (81348) VVF800GRADEDF1W1 Bulk 5 Gallon Can 55 Gallon Drum, 16 Gage 55 Gallon Drum, 18 Gage	gl gl gl gl



**Section II. EXPENDABLE AND DURABLE ITEMS LIST  
(Con't)**

(1) Item Number	(2) Level	(3) National Stock Number	(4) Description (CAGEC) Part Number	(5) U/M U/l
7	C		GREASE: Automotive and Artillery GAA (81349) MIL-G-10924	
		9150-01-197-7693	14 Ounce Cartridge	oz
		9150-01-197-7688	2 1/4 Ounce Tube	oz
		9150-01-197-7690	1 3/4 Pound Can	lb
		9150-01-197-7609	6 1/2 Pound Can	lb
		9150-01-197-7692	35 Pound Pail	lb
		9150-01-197-7691	120 Pound Drum	lb
8	C		OIL: Lubricating GO 75 (81349) MIL-L-2105	
		9150-01-035-5390	1 Quart Can	qt
		9150-01-035-5391	5 Gallon Can	gl
9	C		OIL: Lubricating, Gear, Multipurpose, GO 80/90 (81348) MIL-L-2105	
		9150-01-035-5392	1 Quart Can	qt
		9150-01-035-5393	5 Gallon Can	gl
		9150-01-035-5394	55 Gallon Drum, 16 Gage	gl
10	C		OIL, Lubricating GO 85/140 (81349) MIL-L-2105	
		9150-01-035-5396	55 Gallon Drum	gl
11	C		OIL: Lubricating, Internal Combustion Engine, Arctic, OEA (81349) MIL-L-46167	
		9150-00-402-4478	1 Quart Can	qt
		9150-00-402-2372	5 Gallon Drum	gl
		9150-00-491-7197	55 Gallon Drum	gl
12	C		OIL, Lubricating, Internal Combustion Engine, OE/HDO 10 (81349) MIL-L-2104	

**Section II. EXPENDABLE AND DURABLE ITEMS LIST  
(Con't)**

(1) Item Number	(2) Level	(3) National Stock Number	(4) Description (CAGEC) Part Number	(5) U/M U/I
13	C	9150-00-189-6727	1 Quart Can	qt
		9150-00-186-6668	5 Gallon Can	gl
		9150-00-191-2772	55 Gallon Drum	gl
			OIL:, Lubricating, Engine, OE/HDO 15 W/40 (81349) MIL-L-2104	
14	C	9150-01-151-4117	1 Quart Can	qt
		9150-01-151-4118	5 Gallon Can	gl
		9150-01-151-4118	55 Gallon Drum	gl
			OIL: Lubricating, Internal Combustion Engine, OE/HDO 30 (81349) MIL-L-2104	
15	C	9150-00-186-6681	1 Quart Can	qt
		9150-00-188-9858	5 Gallon Can	gl
		9150-00-189-6729	55 Gallon Drum	gl
			OIL: Lubricating, Internal Combustion Engine, OE/HDO 40 (81349) MIL-L-2104	
16	C	9150-00-189-6730	1 Quart Can	qt
		9150-00-188-9860	5 Gallon Can	gl
		9150-00-188-9862	55 Gallon Drum	gl
			RAG: Wiping (64067) 7920-00-205-1711	
17	C	7920-00-205-1711	50 Pound Bale	lb
			SOLVENT: Dry Cleaning, Type II (81348) P-D-680	
		6650-00-110-4498	1 Pint Can	pt
		6650-00-664-5685	1 Quart Can	qt
		6650-00-281-1985	1 Gallon Can	gl
		6850-00-274-5421	5 Gallon Can	gl
		6850-00-285-8011	55 Gallon Drum	gl

**Section II. EXPENDABLE AND DURABLE ITEMS LIST  
(Con't)**

(1) Item Number	(2) Level	(3) National Stock Number	(4) Description (CAGEC) Part Number	(5) U/M U/I
18	C	9390-00-174-2322	TAPE: Reflective, 2 Inches Wide (81346) ASTM D4956 1800 Inch Roll	in.



**APPENDIX E  
STOWAGE AND DECAL, DATA PLATE,  
AND STENCIL GUIDE**

---

---

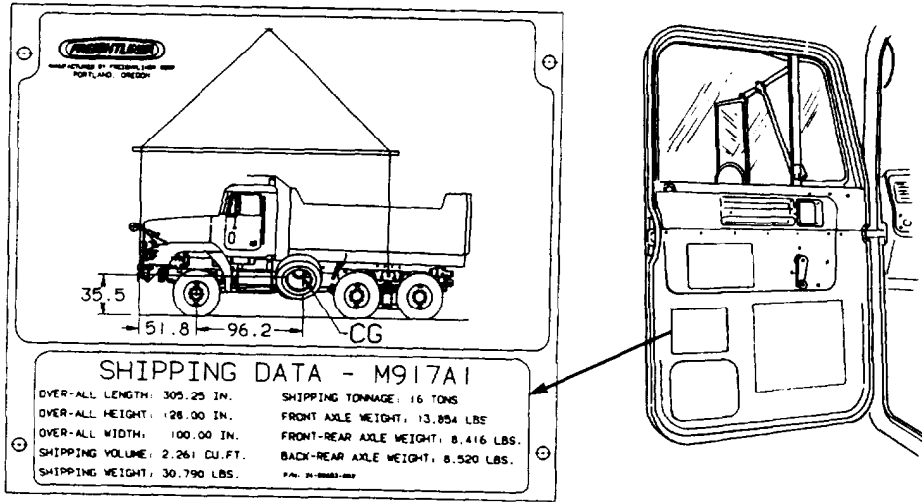
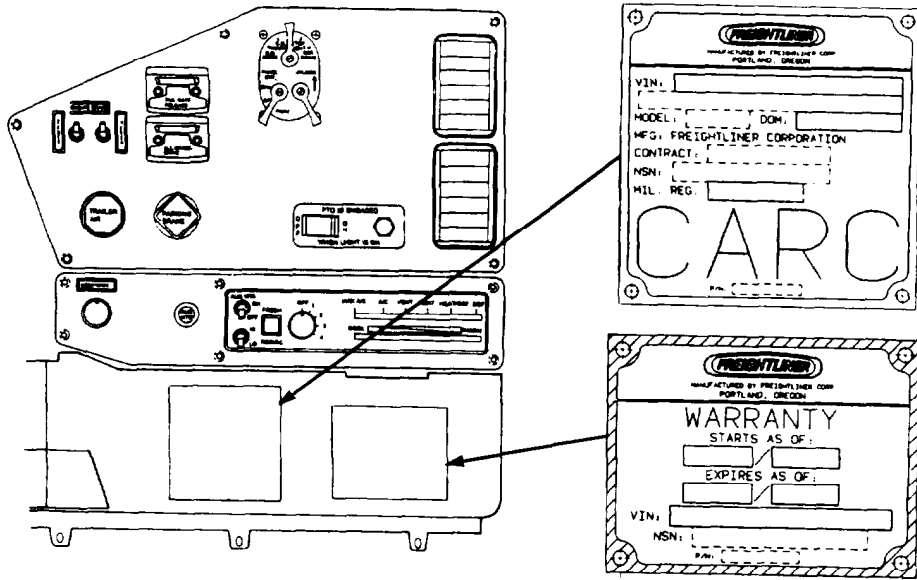
**E-1. SCOPE.**

---

a. This appendix shows the location for stowage of equipment and material required to be carried on the M915 Family of Vehicles. This appendix also includes illustrations showing the location of all decals, data plates, and stencils.

b. Items related to the M917A1 and M917A1 w/MCS chassis are included in this appendix. Items related to the M917A1 and M917A1w/MCS dump body are in TM 5-3805-264-14&P.

**E-2. DECALS AND PLATES.**



**ALL VEHICLES**

E-2. DECALS AND PLATES (Con't).

**COMPONENT DATA - M917A1**

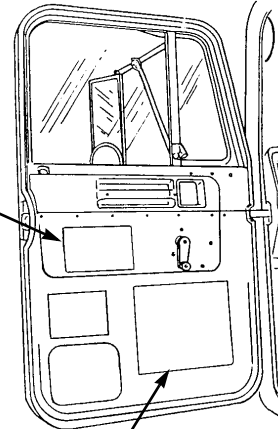
MANUFACTURED BY: FREIGHTLINER CORP.      NOTE: USE VEHICLE IDENTIFICATION NUMBER WHEN ORDERING PARTS.  
 CONTRACT: DA6E07-96-C-X076      WHEELBASE: 175.00 INCHES  
 VEHICLE MODEL NUMBER: M917A1

ENGINE MODEL: DETROIT DIESEL SERIES 60      ENGINE NO.: S01-23563-000  
 TRANS MODEL MAIN: ALLISON AUTOMATIC HT-740      TRANS NO.: S07-13402-000  
 FRT AXLE MODEL: OSHKOSH 18K      FRT AXLE NO.: S10-12482-000  
 REAR AXLE MODEL: ROCKWELL RT-52-160P      REAR AXLE NO.: S11-18234-489  
 GVWR: 68,000 LBS.      RATIO: 4.89 TO 1  
 TRANSFER CASE: OSHKOSH 55000 SERIES T      TRANSFER CASE: 2205810 U

**VEHICLE NOISE EMISSION CONTROL INFORMATION**

THIS VEHICLE IS EXEMPT FROM THE PROVISIONS OF SECTION 10(A)(1), (2), (3), AND (5) OF THE NOISE CONTROL ACT OF 1972.

P/N: 24-00647-000



**LUBRICATION DATA - M917A1**

INTERVAL (MILES)	ITEM	IDENTIFICATION	SERVICE	LUBE POINTS	LUBRICANT
DAILY	1	-PAR/STRG RRVR DIPSTICK	C/F		OE/HDD
DAILY	2	-FUEL FILTER PRIMARY	D*		OE/HDD
DAILY	3	-OIL LEVEL DIPSTICK	C/F		OE/HDD
DAILY	4	-TRANSMISSION DIPSTICK	C/F		OE/HDD
DAILY	29	-RADIATOR COOLANT	C/F		
DC	16	-CRANKCASE	D/F	1	OE/HDD
S	37	-STRG GEAR SHAFT BUSHING	L		GAA
5,000/S	7	-PINTLE HOOD	L	4	GAA
5,000/S	22	-CAMMASTER SLACK ADJUSTERS	L	6	GAA
5,000/S	33	-TRAXION U JOINT	L	2*	GAA
5,000/S	8	-DRAG LINK	L	2	GAA
5,000/S	10	-STRG SHAFT U JOINT & SPLINE	L	3	GAA
5,000/S	11	-REAR AXLE SPRING AND WALKING BEAM	L	4	GAA
5,000/S	12	-FORWARD REAR AXLE DIFF.	C/F		GO
5,000/S	13	-REAR REAR AXLE DIFF.	C/F		GO
5,000/S	14	-FRONT AXLE DIFFERENTIAL	C/F		GO
5,000/S	15	-FRONT AXLE SPRING	L	6	GAA
5,000	31	-TRANSFER CASE	C/F		GO
5,000	30	-TIE ROD	L	2	GAA
10,000	2	-FUEL FILTER PRIMARY	CH		
10,000	18	-FUEL FILTER SECONDARY	CH		
10,000	31	-TRANSFER CASE	D/F		GO
20,000/A	17	-OIL FILTER FULL FLOW	CH		OE/HDD
20,000/A	9	-OIL FILTER BYPASS	CH		OE/HDD
20,000/DC	20	-TRANSMISSION	D/F		OE/HDD
20,000/A	21	-TRANSMISSION FILTER	CH		OE/HDD
20,000/A	1	-PAR/STRG RESERVOIR	D/F		OE/HDD
20,000/A	1	-PAR/STRG FILTER	CH		
20,000/S	24	-CAMSHAFT ROLLER JOURNALS AND BUSHINGS	L	6	GAA
20,000/S	25	-DRIVE/INE UNIVERSAL JOINT, SLIP YOKES AND SPLINE	L	20	GAA
75,000/A	26	-WHEEL BEARINGS	I/A/L		GAA
75,000/A	27	-FORWARD REAR AXLE OIL FILTER	CH		
75,000/A	12	-FORWARD REAR AXLE DIFF.	D/F		GO
75,000/A	13	-REAR REAR AXLE DIFF.	D/F		GO
75,000/A	14	-FRONT AXLE DIFFERENTIAL	D/F		GO
75,000/A	39	-PULLEY FAN DRIVE	L	1	GAA
75,000/A	5	-TACH DRIVE	L	1	GAA

**LUBRICATION KEY**

C = CHECK      OE/HDD = LUBRICATING OIL, INTERNAL COMBUSTION TACTICAL SERVICE, (MIL-L-21043).

F = FILL      GAA = GREASE, AUTOMOTIVE AND ARTILLERY, (MIL-G-10924).

D = DRAIN      L = LUBRICATE      GO = LUBRICATING OIL, GEAR, MULTIPURPOSE, (MIL-L-21051).

I = INSPECT      CH = CHANGE      B = ITEM APPEARS ON BOTH SIDES OF TRUCK

GO = ON CONDITION      D/F = DRAIN/FILL      OC = ON CONDITION

IN = ADJUST      \* SEE OPERATORS MANUAL FOR DETAILS

CL = CLEAN

**TIRE AND RIM DATA**

	GAWR	LCM	TIRES	RIMS	PSI (COLD)
FRONT AXLE SINGLE TIRES	16,000	LB	MCH 3856SR225K21	22.5 x 12.25	90
REAR AXLE DUAL TIRES	26,000	LB	MCH 3158QR225K21	22.5 x 9.0	90

NOTE: TO VALIDATE WARRANTY, INITIAL SERVICE MUST BE PERFORMED AT 5,000 MILES. SERVICE INTERVALS SHOWN ABOVE BEGIN THEREAFTER. REFER TO INSTRUCTIONAL MANUAL FOR COMPLETE INFORMATION REGARDING LUBRICATION OF VEHICLE.

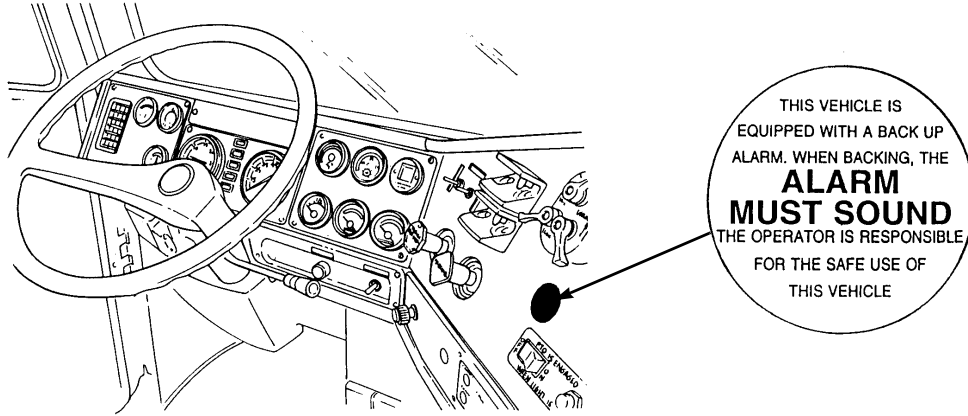
P/N: 24-00647-000

ALL VEHICLES

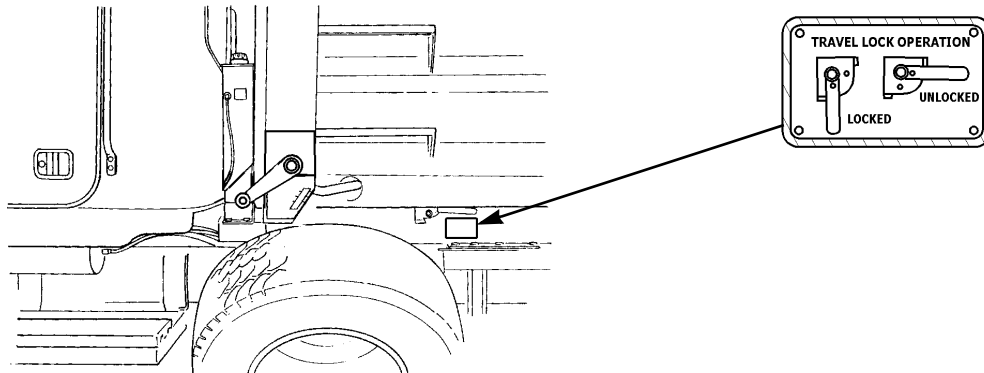
---

**E-2. DECALS AND PLATES (Con't).**

---



**M917A1 AND M917A1 W/MCS**



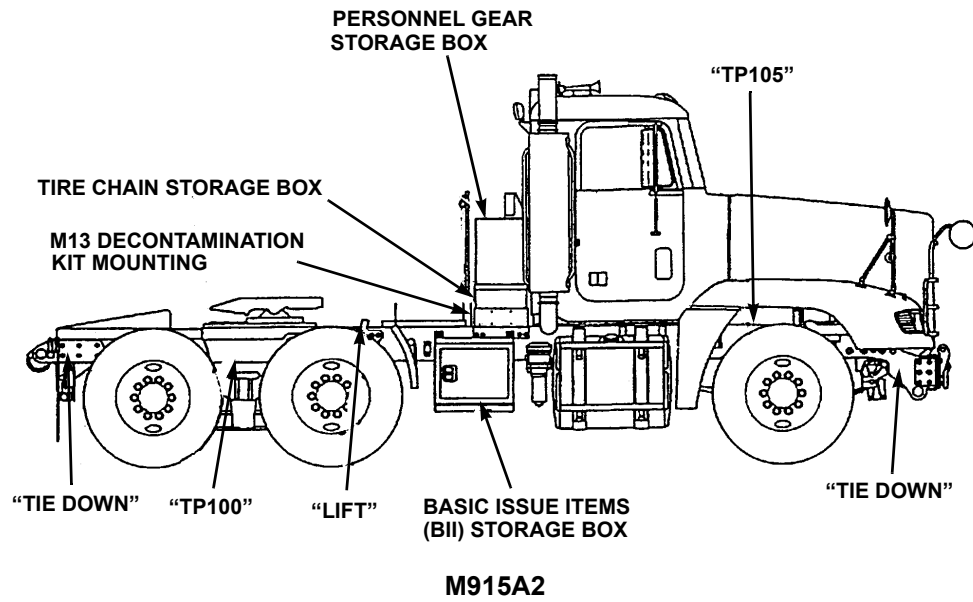
**M917A1 AND M917A1 W/MCS**



---

**E-3. STOWAGE AND STENCILS.**

---

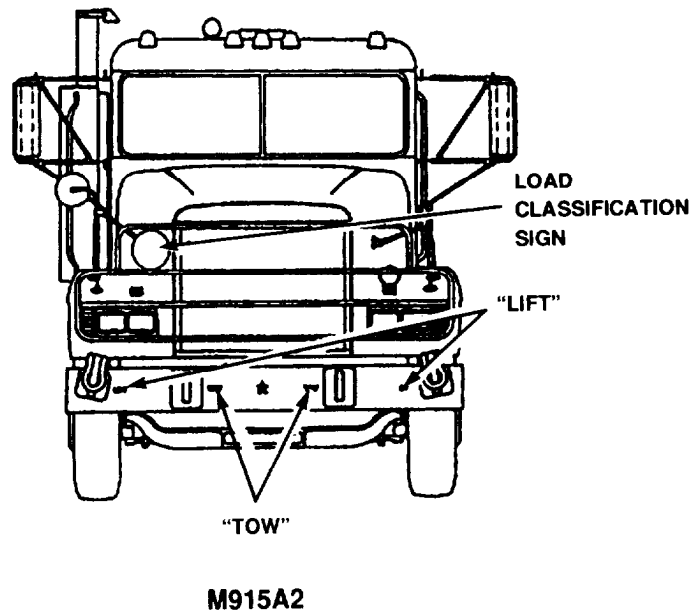
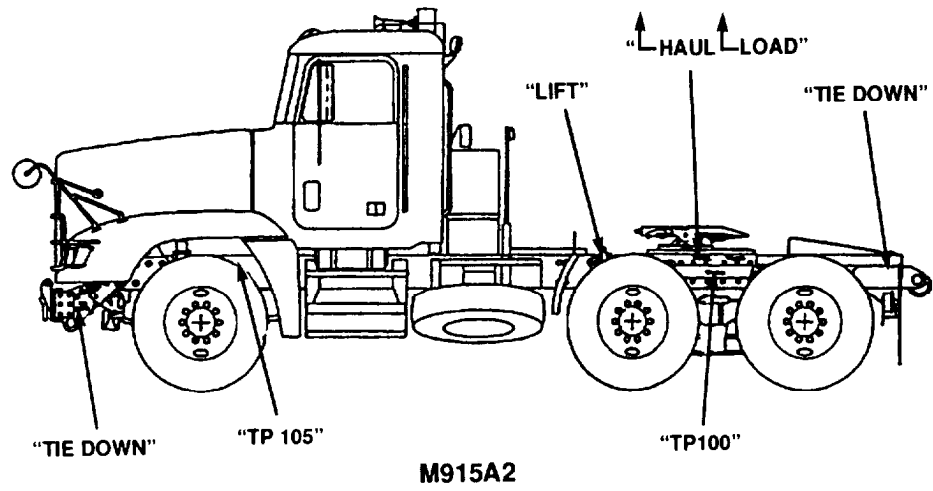




---

E-3. STOWAGE AND STENCILS (Con't).

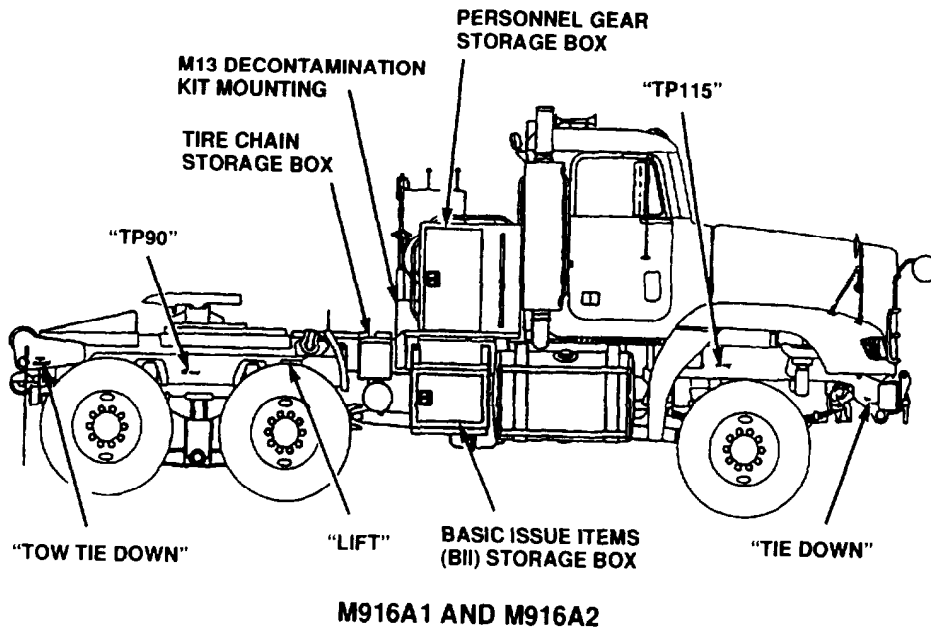
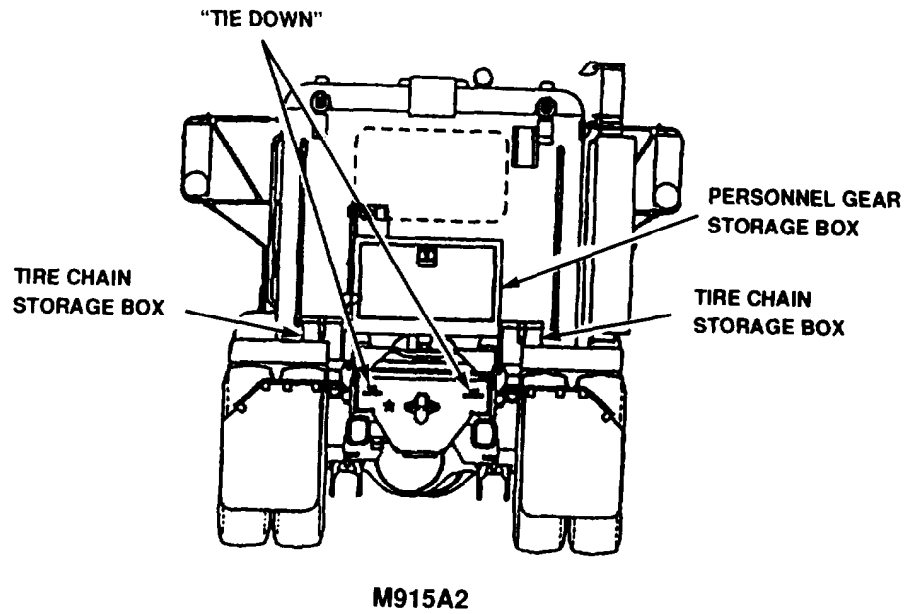
---



---

**E-3. STOWAGE AND STENCILS (Con't).**

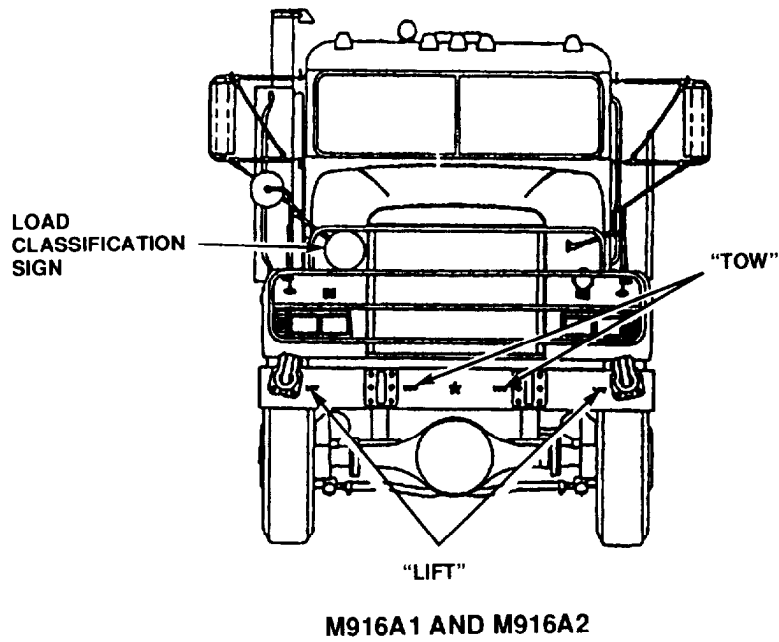
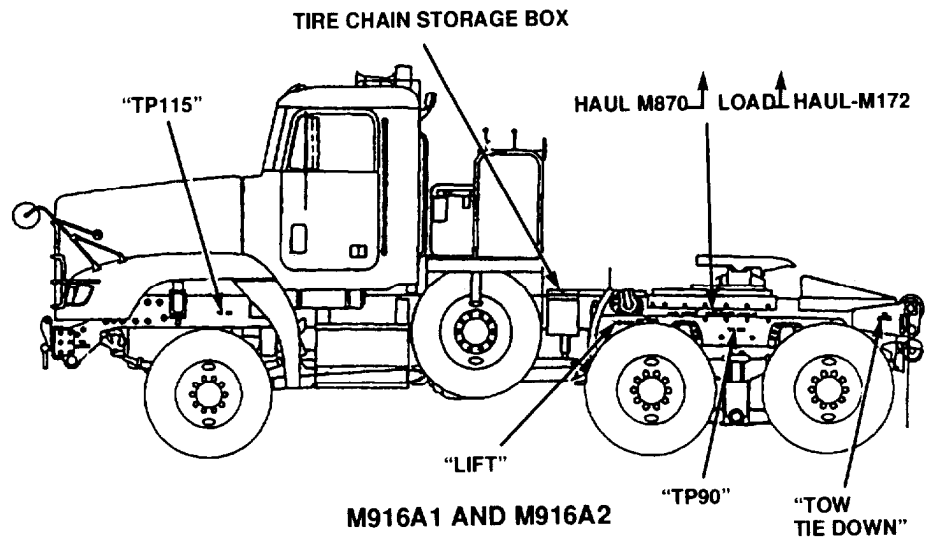
---



---

E-3. STOWAGE AND STENCILS (Con't).

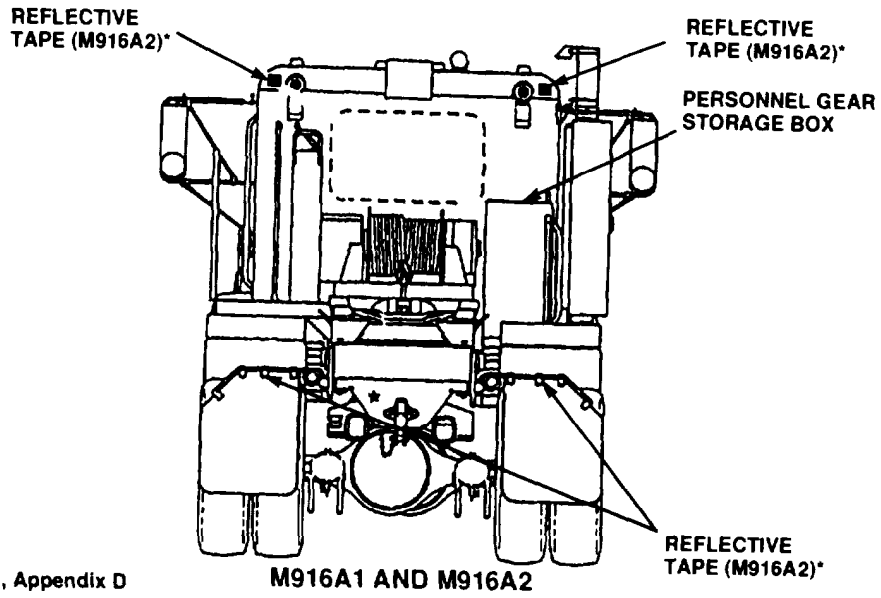
---



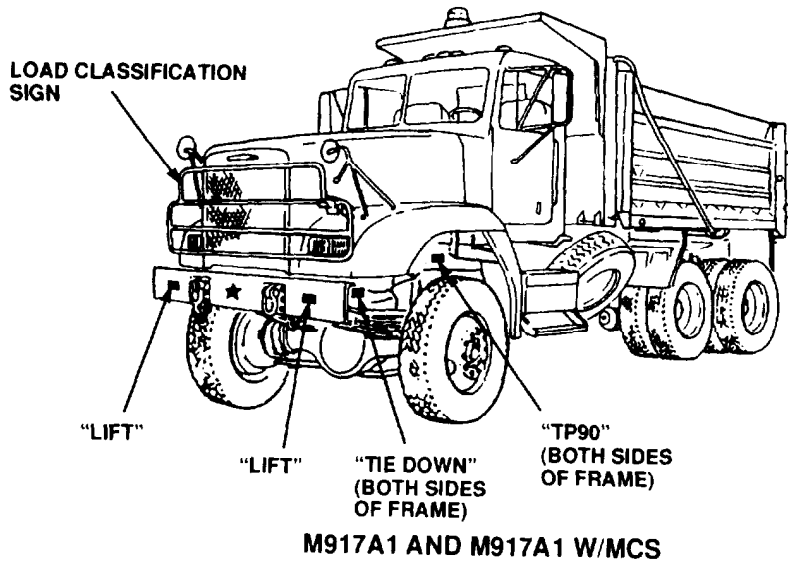
---

**E-3. STOWAGE AND STENCILS (Con't).**

---



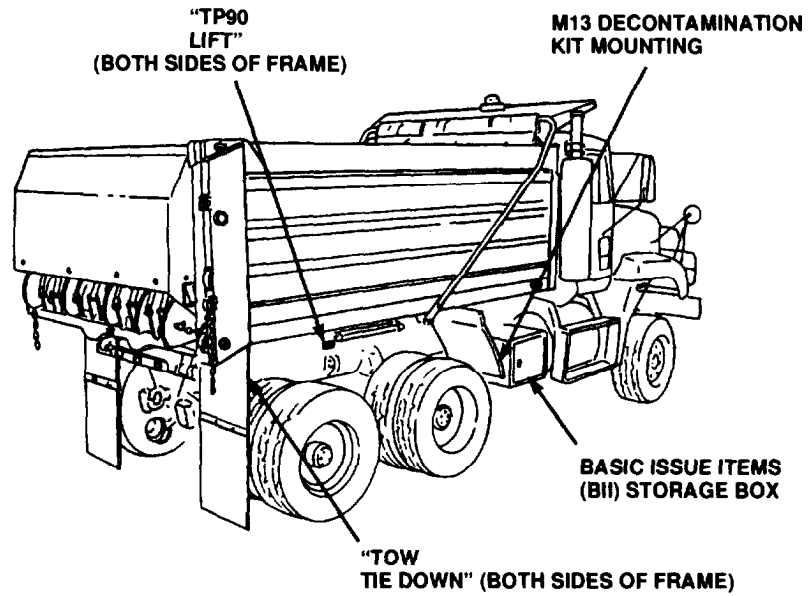
\*Item 18, Appendix D



---

E-3. STOWAGE AND STENCILS (Con't).

---



**M917A1 AND M917A1 W/MCS**





## APPENDIX F

### LUBRICATION INSTRUCTIONS

---

---

#### F-1. GENERAL.

---

##### NOTE

- **These instructions are mandatory.**
- **This equipment is enrolled in the Army Oil Analysis Program (AOAP). Engine oil, transmission oil, and hydraulic fluid must be sampled every 90 days as prescribed by DA Pam 738-750.**
- **For lubrication instructions for the M917A1 and M917A1 w/MCS Dump Truck Body, refer to TM 5-3805-264-14&P.**
  - a. The M915 family of vehicles must receive lubrication with approved lubricants at recommended intervals in order to be mission-ready at all times.
  - b. The Lubrication Chart shows lubrication points, items to be lubricated, the required lubricants, and recommended intervals for lubrication by the operator/crew. Any special lubrication instructions required for specific components are contained in the NOTES section of the chart.
  - c. The KEY and CHARTS A through E provide information needed to select the proper lubricant for various temperature ranges and uses, and identify the interval.
  - d. Recommended intervals are based on normal conditions of operation, temperature, and humidity. When operating under extreme conditions, lubricants should always be changed more frequently. When in doubt, notify your supervisor.

---

#### F-2. SPECIFIC LUBRICATION INSTRUCTIONS.

---

- a. Keep all lubricants in a closed container and store in a clean, dry place away from extreme heat. Keep container covers clean and do not allow dust, dirt, or other foreign material to mix with lubricants. Keep lubrication equipment clean and ready for use.
- b. Maintain a record of lubrication performed and report any problems noted during lubrication. Refer to DA Pam 738-750 for maintenance forms and procedures to record and report any findings.
- c. Keep all external parts of equipment not requiring lubrication free of lubricants. After lubrication, wipe off excess lubricant to prevent accumulation of foreign matter.
- d. Refer to FM 9-207 for lubrication instructions in cold weather.

LUBRICATION CHART

**TRUCK, TRACTOR, LINE HAUL:  
52,000 GVWR, 6 X 4, M915A2  
(NSN 2320-01-272-5029)**

**TRUCK, TRACTOR, LIGHT EQUIPMENT TRANSPORTER (LET):  
68,000 GVWR, 6 X 6, W/WINCH, M916A1  
(NSN 2320-01-272-5028)**

**TRUCK, TRACTOR, LIGHT EQUIPMENT TRANSPORTER (LET):  
68,000 GVWR, 6 X 6, W/WINCH, M916A2  
(NSN 2320-01-431-1163)**

**TRUCK, DUMP, HEAVY, CHASSIS:  
68,000 GVWR, 6 X 6, 14 CU YD, ON-OFF HIGHWAY  
M917A1 (NSN 3805-01-431-1165)  
M917A1 W/MCS (NSN 3805-01-432-8249)**

This Lubrication Chart is for the operator/crew (C). Lubrication intervals (on-condition or hard time) are based on normal operation. Lubricate more during constant use and less during inactive periods. Use correct grade of lubricant for seasonal temperature expected.

For equipment under manufacturer's warranty, hard time oil service intervals shall be followed. Intervals shall be shortened if lubricants are known to be contaminated or if operation is under adverse conditions (e.g., longer than usual operating hours, extended idling periods, extreme dust, etc.).

**WARNING**

**Dry cleaning solvent, P-D-680, is toxic and flammable. Always wear protective goggles and**

**gloves, and use only in a well-ventilated area. Avoid contact with skin, eyes, and clothes, and DO NOT breathe vapors. DO NOT use near open flame or excessive heat. The solvent's flash point is 100°F-138°F (38°C-59°C). If you become dizzy while using cleaning solvent, immediately get fresh air and medical help. If solvent contacts eyes, immediately wash your eyes and get medical aid.**

Clean area around lubrication points with dry cleaning solvent (Item 17, Appendix D) or equivalent before lubricating equipment. After lubrication, wipe off excess lubricant to prevent accumulation of foreign matter.

Dashed leader line indicates lubrication on both sides of vehicle.

**M915A2**

LUBRICANT • INTERVAL      INTERVAL • LUBRICANT

Primary Fuel  
Filter/Water  
Separator  
Drain Moisture  
(C)  
(See View A)

Wheel  
Bearings  
Check and Fill  
(C)  
(See View B &  
Note 1)

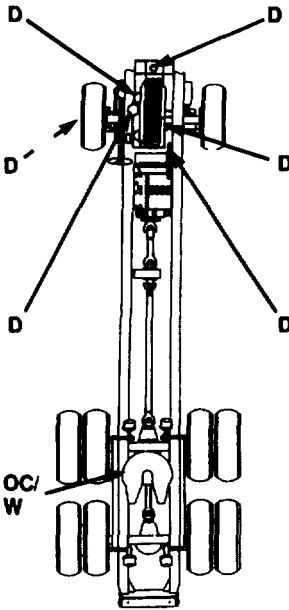
Power  
Steering Reser-  
voir  
Check & Fill (C)  
See View C &  
Note 2)

Fifth Wheel  
(Clean & Grease)  
(C)  
(See View D and  
Note 3)

**GO**

**OE/  
HDO**

**GAA**



Radiator  
Check & Fill (C)  
(See Note 4)

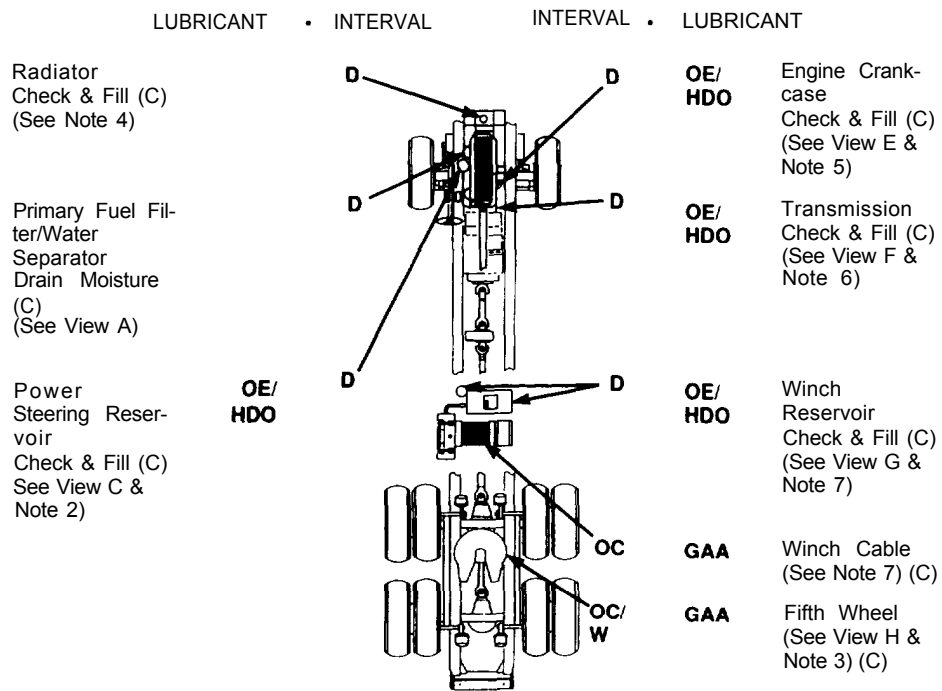
**OE/  
HDO**

**OE/  
HDO**

Engine Crank-  
case  
Check & Fill (C)  
(See View E &  
Note 5)

Transmission  
Check & Fill (C)  
(See View F &  
Note 6)

**M916A1 AND M916A2**



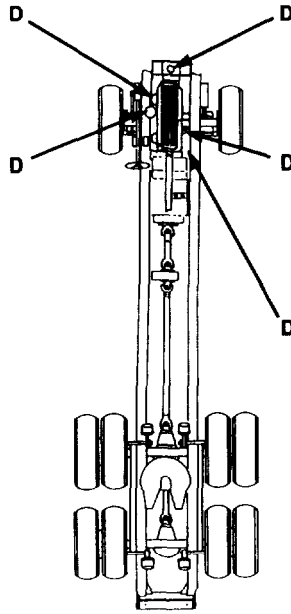
**M917A1 AND M917A1 W/MCS**

LUBRICANT • INTERVAL      INTERVAL • LUBRICANT

Primary Fuel Filter/Water Separator  
Drain Moisture (C)  
(See View A)

Power Steering Reservoir  
Check & Fill (C)  
See View C & Note 2)

**OE/  
HDO**



Radiator  
Check & Fill (C)  
(See Note 4)

**OE/  
HDO**

Engine Crankcase  
Check & Fill (C)  
(See View E & Note 5)

**OE/  
HDO**

Transmission  
Check & Fill (C)  
(See View F & Note 6)

**- KEY -**

Lubricant/ Component	Refill Capacity	Expected Temperatures*			Intervals
		+6° to +122°F (-14°C to +50°C)	-4°F to +50°F (-20°C to +10°C)	-67°F to +32°F (-55°C to 0°C)	
OE/HDO (MIL-L-2104) Lubricating Oil, ICE, Tactical					D - Daily W - Weekly OC - On- Condi- tion
OEA (MIL-L-46167) Lubricating Oil, ICE, Arctic					
Engine Crankcase w/ Filters	41 Qt (38.8 L)	See Chart A			
Transmission	33 Qt (31.2 L)	See Chart B			
Power Steering Reservoir	2 Qt (19.3 L)	See Chart A			
Winch Reservoir (M916A1 & M916A2)	42 Gal. (159 L)	See Chart C			
Oil Can Points	As Req'd	See Chart A			
GO (MIL-L-2105) Lubricating Oil, Gear, Multipurpose					
Front Axle Wheel Bearings (M915A2)	As Req'd	See Chart D			
GAA (MIL-G-10924) Grease, Automotive and Artillery					
Fifth Wheel (All Except M917A1)	As Req'd	All Temperatures			
Winch Cable (M916A1 and M916A2)	As Req'd	All Temperatures			

Lubricant/ Component	Refill Capacity	Expected Temperatures*			Intervals
		+6°F to +122°F (-14°C to +50°C)	-4°F to +50°F (-20°C to +10°C)	-67°F to +32°F (-55°C to 0°C)	
ANTIFREEZE (MIL-A-46153) Ethylene Glycol, Inhibited, Heavy Duty					
ANTIFREEZE (MIL-A-11755) Ethylene Glycol, Arctic Grade					
Engine Radiator	65 Qt (61.5 L)	See Chart E			

\*For Arctic Operation, refer to FM 9-207.

**CHART A-ENGINE, POWER STEERING, AND OIL CAN POINTS**

Lubricant	EXPECTED TEMPERATURES																			
	°F	-70	-60	-50	-40	-30	-20	-10	0	+10	+20	+30	+40	+50	+60	+70	+80	+90	+100	+120
	°C	-57	-51	-46	-40	-34	-29	-23	-18	-12	-7	-1	+4	+10	+16	+21	+27	+32	+38	+49
OE/HDO (MIL-L- 2104)	Lubricating Oil, ICE, Tactical																			
OEA (MIL-L- 46167)	Lubricating Oil, ICE, Arctic																			
OE/HDO-15/ 40 (0 - 1236)																				
OE/ HDO-10 * (0 - 237)																				
OE/HDO-30 (0 - 238)																				
OE/HDO-40 (N/A)																				
OEA * (0 - 183)																				

\*If OEA lubricant is required to meet the low expected-temperature range, OEA lubricant is to be used in lieu of OE/HDO-10 lubricant for all expected temperatures where OE/HDO-10 is specified.

### CHART B-TRANSMISSION

Lubricant	EXPECTED TEMPERATURES																				
	°F	-70	-60	-50	-40	-30	-20	-10	0	+10	+20	+30	+40	+50	+60	+70	+80	+90	+100	+120	
	°C	-57	-51	-46	-40	-34	-29	-23	-18	-12	-7	-1	+4	+10	+16	+21	+27	+32	+38	+49	
OE/HDO (MIL-L-2104)	Lubricating Oil, ICE, Tactical																				
OEA (MIL-L-46167)	Lubricating Oil, ICE, Arctic																				
OE/HDO-15/40 (0-1236)																					
OE/HDO-10* (0-237)																					
OEA* (0-183)																					

\*If OEA lubricant is required to meet the low expected-temperature range, OEA lubricant is to be used in lieu of OE/HDO-15/40 lubricant for all expected temperatures where OE/HDO-10 and OE/HDO-15/40 are specified.

### CHART M16A1 AND M916A2 WINCH RESERVOIR

Lubricant	EXPECTED TEMPERATURES																				
	°F	-70	-60	-50	-40	-30	-20	-10	0	+10	+20	+30	+40	+50	+60	+70	+80	+90	+100	+120	
	°C	-57	-51	-46	-40	-34	-29	-23	-18	-12	-7	-1	+4	+10	+16	+21	+27	+32	+38	+49	
OE/HDO (MIL-L-2104)	Lubricating Oil, ICE, Tactical																				
OEA (MIL-L-46167)	Lubricating Oil, ICE, Arctic																				
OE/HDO-10* (0-237)																					
OEA* (0-183)																					

\*If OEA lubricant is required to meet the low expected-temperature range, OEA lubricant is to be used in lieu of OE/HDO-10 lubricant for all expected temperatures where OE/HDO-10 is specified.



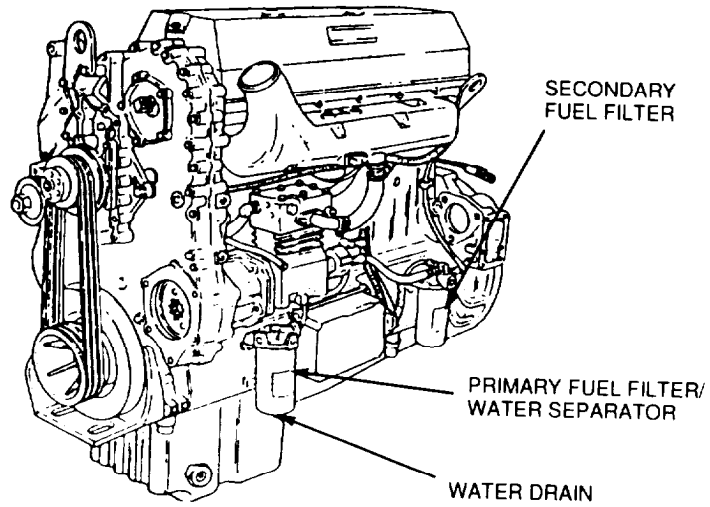
**CHART D-M915A2 FRONT AXLE WHEEL BEARINGS**

Lubricant	EXPECTED TEMPERATURES																			
	°F	-70	-60	-50	-40	-30	-20	-10	0	+10	+20	+30	+40	+50	+60	+70	+80	+90	+100	+120
	°C	-57	-51	-46	-40	-34	-29	-23	-18	-12	-7	-1	+4	+10	+16	+21	+27	+32	+38	+49
GO (MIL-L-2105)	Lubricating Oil, Gear, Multipurpose																			
GO-75 (O - 186)																				
GO-80/90 (O - 226)																				
GO-85/140 (O - 228)																				

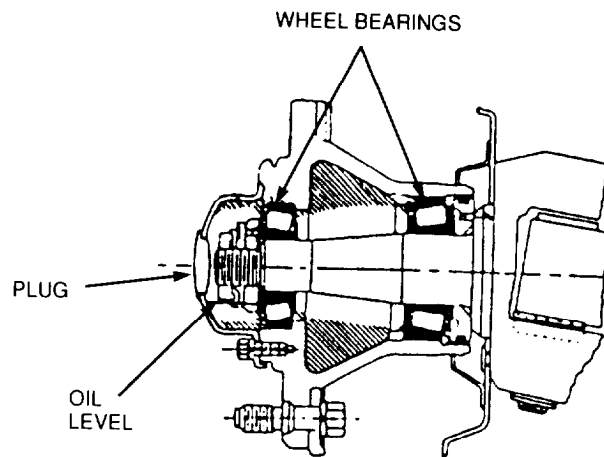
**CHART E-ANTIFREEZE**

Lubricant	EXPECTED TEMPERATURES																			
	°F	-90	-80	-70	-60	-50	-40	-30	-20	-10	0	+10	+20	+30	+40	+50	+60	+70	+80	+90
	°C	-68	-62	-57	-51	-46	-40	-34	-29	-23	-18	-12	-7	-1	+4	+10	+16	+21	+27	+32
MIL-A-46153	Antifreeze, Ethylene Glycol, Inhibited, Heavy Duty																			
MIL-A-11755	Antifreeze, Arctic Grade																			
MIL-A-46153																				
MIL-A-11755																				

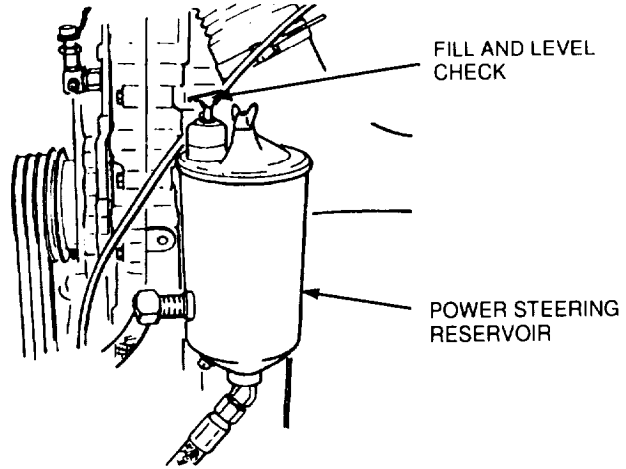
**VIEW A-FUEL FILTER/WATER SEPARATOR**



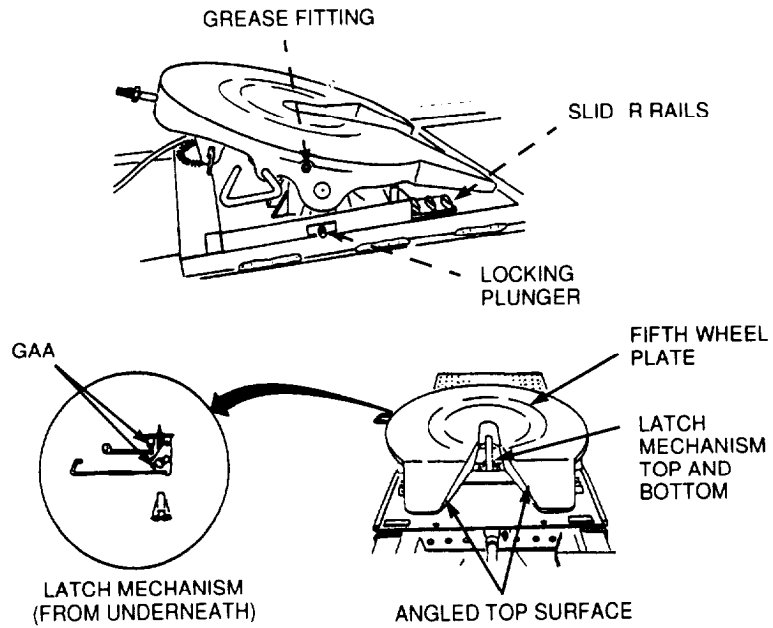
**VIEW B-M915A2 FRONT AXLE WHEEL BEARINGS**



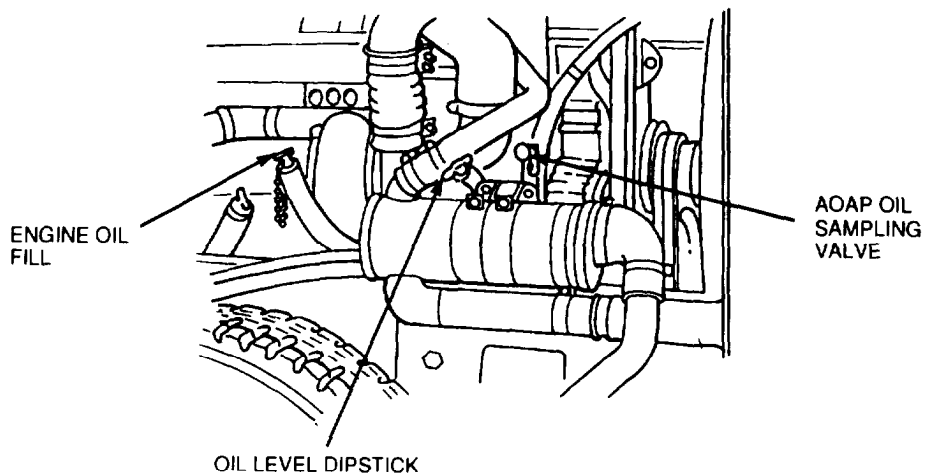
### VIEW C-POWER STEERING RESERVOIR



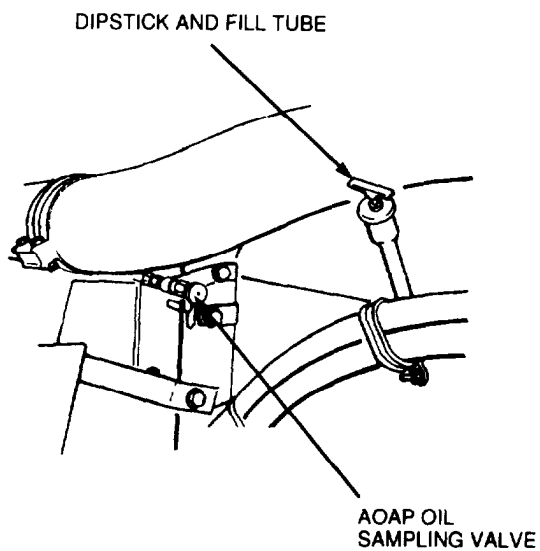
### VIEW D-M915A2 FIFTH WHEEL



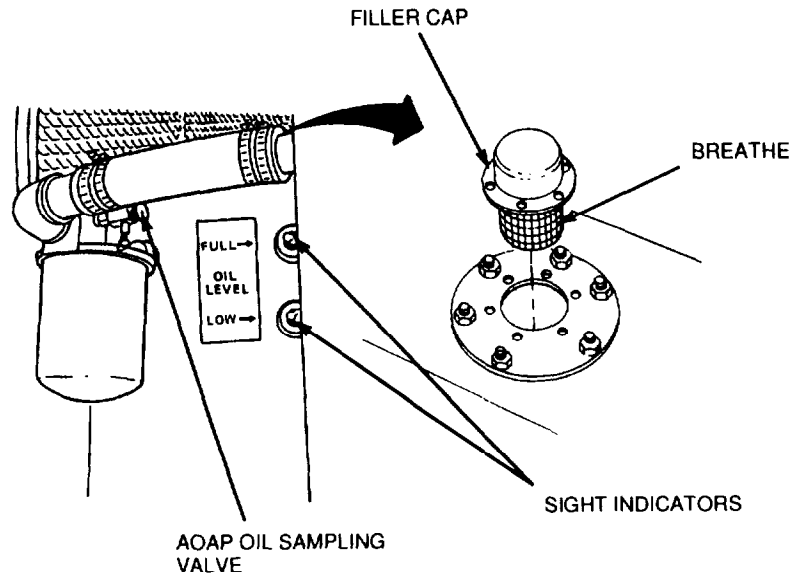
**VIEW E-ENGINE CRANKCASE**



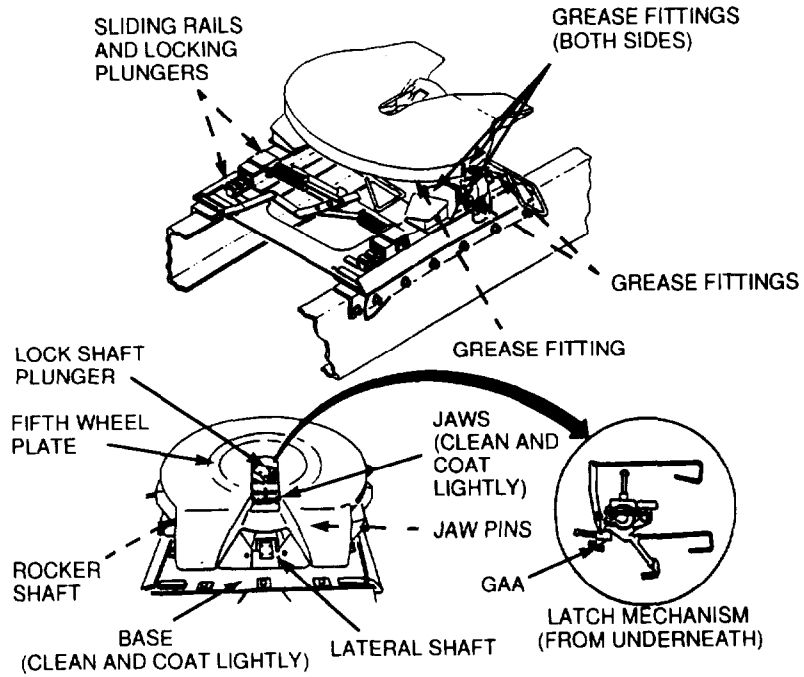
**VIEW F-TRANSMISSION**



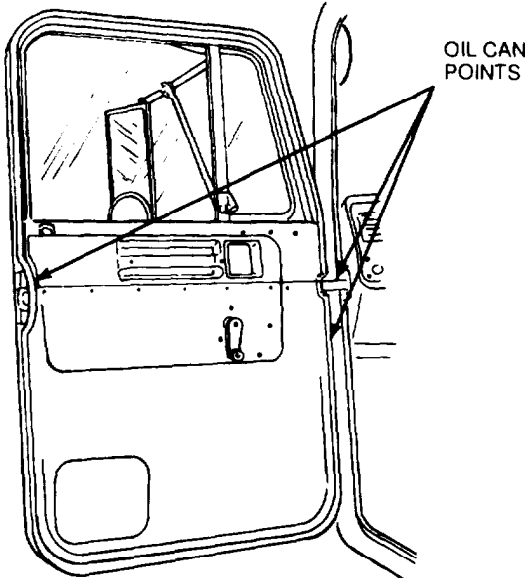
### VIEW G-M916A1 AND M916A2 WINCH RESERVOIR



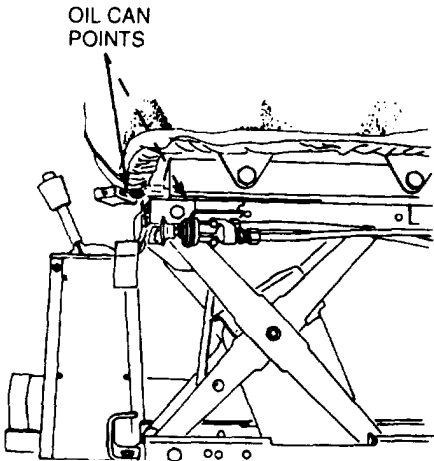
### VIEW H-M916A1 AND M916A2 FIFTH WHEEL



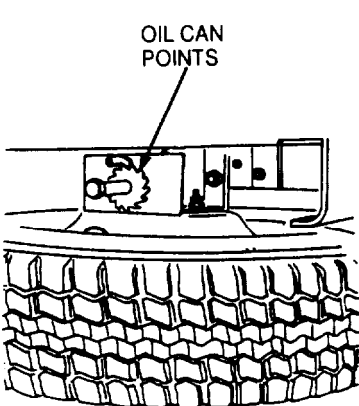
VIEW I-CAB DOOR



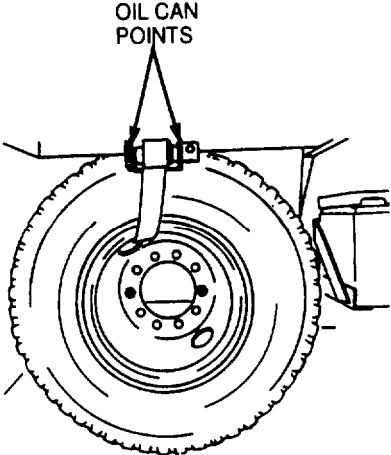
VIEW J-SEATS



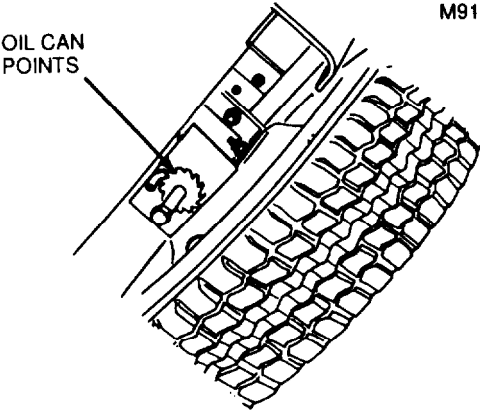
VIEW K-SPARE WHEEL AND TIRE CARRIER



M915A2



M916A1 AND M916A2



M917A1 AND M917A1 W/MCS

**1. M915A2 FRONT AXLE WHEEL**

**BEARINGS.** Daily, check that level of gear lubricating oil is visible in sight glass. If oil is not visible, remove rubber plug and add GO until level is even with plug opening. Install rubber plug.

**2. POWER STEERING RESER-**

**VOIR.** Daily, with engine running and fluid at operating temperature, remove dipstick from reservoir and check level of lubricating oil on dipstick. Add OE/HDO to bring level above the ADD mark on dipstick.

**3. FIFTH WHEEL (ALL EXCEPT M917A1 AND M917A1 W/MCS).**

**WARNING**

Dry cleaning solvent, P-D-680, is toxic and flammable. Always wear protective goggles and gloves, and use only in a well-ventilated area. Avoid contact with skin, eyes, and clothes, and DO NOT breathe vapors. DO NOT use near open flame or excessive heat. The solvent's flash point is 100°F-138°F (38°C-59°C). If you become dizzy while using cleaning solvent, immediately get fresh air and medical help. If solvent contacts eyes, immediately wash your eyes and get medical aid.

Weekly or on-condition, apply GAA to top plate, latch mechanism, slider rails, locking plungers, and all lubrication fittings. Clean and lubricate moving parts on underside with dry cleaning solvent and OE/HDO.

**4. RADIATOR.**

**WARNING**

Let radiator cool before removing cap. Remove cap in two steps. First place thick cloth over cap and slowly turn cap left to its first stop; pause, and allow pressure to escape from cooling system. Then turn cap further left until you can remove it. Failure to follow this procedure can result in serious burns.

Daily, with engine cool, remove radiator cap. Check level of coolant in radiator. Coolant must be within 2 1/2 in. (6.4 cm) below filler neck. Add coolant to correct level. Install radiator cap.

**5. ENGINE CRANKCASE.** Daily, check level of lubricating oil. Wait 10 minutes after shutting down engine to allow oil to drain back into crankcase. To ensure an accurate reading, vehicle must be parked on level ground. Safe operating level is between ADD and FULL marks on dipstick. As required, add OE/HDO through filler opening. DO NOT overfill.

**6. TRANSMISSION.**

**COLD OIL CHECK (COLD RUN BAND).** Run engine for one minute at 1000 rpm to charge the system. Idle engine until transmission reaches 60°-120°F (16°-49°C). With engine idling and transmission in Neutral (N), remove dipstick from oil filler tube and check oil level. Oil registering in the COLD RUN band indicates a sufficient quantity of oil to safely operate the transmission until temperature reaches 160°-200°F (71°-93°C). When temperature reaches 160°-200°F (71°-93°C), a hot oil check must be performed.



**HOT OIL CHECK (HOT RUN BAND).**

Be sure temperature has reached 160°-200°F (71°-93°C). With engine idling and transmission in Neutral (N), remove dipstick from oil filler tube and check oil level. If oil registers in the HOT RUN band, quantity of oil in transmission is safe for operating the vehicle. If it registers on or below the bottom line of the HOT RUN band, add the required amount of oil to bring oil level to the middle of the HOT RUN band. Approximately 1 quart (0.95 liter) of oil is required to move the oil level from the bottom line to the middle line of the HOT RUN band.

**7. M916A1 AND M916A2 WINCH:**

**HYDRAULIC RESERVOIR.** Daily, check level of lubricating oil in reservoir. Level is low if not visible or just visible in lower sight indicator. To add oil, remove filler cap and add OE/HDO until level is visible in top sight indicator. Before reinstalling filler cap, remove any debris from filler cap strainer. Notify Unit Maintenance to change oil if oil appears milky or contains metallic particles.

**WARNING**

- **Always wear heavy gloves when you handle winch wire rope. Never allow wire-rope to run through your hand as broken wires can cause injury.**
- **Hearing protection is required for operator and all personnel working on or around winch station during operation.**

**WINCH CABLE.** On-condition, clean and lubricate cable. Unwind cable and soak in clean OE/HDO overnight. Clean with a brush. Wipe off excess oil. Coat with GAA before rewinding cable on drum.

**8. OIL CAN POINTS.** On-condition or weekly, lubricate sparingly with OE/HDO: door hinges and latches (View I); driver and passenger seat adjuster; and sliding tracks (View J); and spare wheel and tire carrier ratchet gear shaft (View K).



<i>Subject</i>	<i>Paragraph</i>	<i>Page</i>
<b>A</b>		
Abbreviations, List of . . . . .	1-8	1-3
Additional Controls and Indicators . . . . .	2-8	2-30
Air Conditioning System (All Except M915A2 and M916A1), Principles of Operation . . . . .	1-23	1-34
Air System, Principles of Operation . . . . .	1-19	1-30
<b>B</b>		
Battery Box Cover Replacement . . . . .	3-12	3-38
Brakes, Cage and Uncage . . . . .	2-38	2-125
Brakes, Principles of Operation . . . . .	1-20	1-30
<b>C</b>		
Cab Floor-Mounted Controls . . . . .	2-4	2-21
Cage and Uncage Brakes . . . . .	2-38	2-125
Central Tire Inflation System (CTIS) (M917A1 and M917A1 w/MCS), Principles of Operation . . . . .	1-24	1-34
Characteristics, Capabilities, and Features, Equipment . . . . .	1-9	1-5
Cleaning Vehicle . . . . .	3-5	3-17
Controls and Indicators:		
Additional . . . . .	2-8	2-30
CTIS (M917A1 and M917A1 w/MCS) . . . . .	2-6	2-26
Instrument Panel . . . . .	2-2	2-2
Controls:		
Cab Floor-Mounted . . . . .	2-4	2-21
Seat . . . . .	2-5	2-24
Steering Wheel and Column-Mounted . . . . .	2-3	2-20
Winch (M916A1 and M916A2) . . . . .	2-7	2-29
Cooling System, Principles of Operation . . . . .	1-17	1-28
Corrosion Prevention and Control (CPC) . . . . .	1-3	1-2
Couple to Truck (All Except M917A1 and M917A1 w/MCS) . . . . .	2-23	2-102
CTIS (M917A1 and M917A1 w/MCS):		
Controls and Indicators . . . . .	2-6	2-26
Operate . . . . .	2-17	2-89

<i>Subject</i>	<i>Paragraph</i>	<i>Page</i>
<b>D</b>		
Daily Checks .....	2-13	2-82
Damaged Tire, Driving With (M917A1 and M917A1 w/MCS) .....	2-46	2-140
Data, Equipment .....	1-12	1-16
Destruction of Army Materiel to Prevent Enemy Use .....	1-4	1-2
Differences Between Models .....	1-11	1-15
Drive Train, Principles of Operation .....	1-14	1-26
Driving .....	2-19	2-96
Driving Tips .....	2-18	2-93
Driving With a Damaged Tire (M917A1 and M917A1 w/MCS) .....	2-46	2-140
<b>E</b>		
Electrical System, Principles of Operation .....	1-18	1-29
Engine:		
Shut Down .....	2-20	2-97.0
Start .....	2-14	2-85
Equipment:		
Characteristics, Capabilities, and Features .....	1-9	1-5
Data .....	1-12	1-16
Exhaust System, Principles of Operation .....	1-16	1-28
Extreme Cold, Operate in .....	2-39	2-127
Extreme Heat, Operate .....	2-40	2-131
<b>F</b>		
Fording .....	2-42	2-133
Front Wheel and Tire Assembly Replacement (M917A1 and M917A1 w/MCS) .....	3-10	3-28
Fuel System, Principles of Operation .....	1-15	1-27
<b>G</b>		
General PMCS Procedures .....	2-11	2-34

<i>Subject</i>	<i>Paragraph</i>	<i>Page</i>
<b>H</b>		
Heater and Defroster, Operate .....	2-33	2-117
Hydraulic System (All Except M915A2), Principles of Operation .....	1-22	1-32
<b>I</b>		
Initial Adjustments .....	2-13	2-82
Initial Adjustments, Daily Checks, and Self-Tests .....	2-13	2-82
Instrument Panel, Controls and Indicators .....	2-2	2-2
<b>L</b>		
Lights, Operate .....	2-31	2-116
List of Abbreviations .....	1-8	1-3
Location and Description of Major Components .....	1-10	1-6
<b>M</b>		
Maintenance Forms and Procedures .....	1-2	1-2
Major Components, Location and Description .....	1-10	1-6
Manual Tire Inflation .....	3-7	3-19
Mud Flap Stowage (All Except M917A1 and M917A1 w/MCS) .....	2-26	2-108
Mud or Soft Surfaces, Operate in .....	2-41	2-132
<b>N</b>		
Nomenclature Cross-Reference List .....	1-7	1-3
<b>O</b>		
Operate CTIS (M917A1 and M917A1 w/MCS) .....	2-17	2-89
Operate:		
Air Conditioning (All Except M915A2 and M916A1) .....	2-29	2-113
Heater and Defroster .....	2-33	2-117
In Extreme Cold .....	2-39	2-127
In Extreme Heat .....	2-40	2-131
In Mud or Soft Surfaces .....	2-41	2-132
In Woods or On Rocky Terrain .....	2-44	2-135

<i>Subject</i>	<i>Paragraph</i>	<i>Page</i>
Operate (Con't):		
Lights .....	2-31	2-116
Portable Fire Extinguisher .....	2-30	2-114
Power Take-Off (PTO) (All Except M915A2) .....	2-27	2-109
Sandy or Dusty Conditions .....	2-43	2-134
Sliding Fifth Wheel:		
M915A2 .....	2-21	2-98
M916A1 and M916A2 .....	2-22	2-100
Snow and Ice .....	2-45	2-136
Transfer Case (All Except M915A2) .....	2-16	2-88
Transmission .....	2-15	2-87
Winch (M916A1 and M916A2) .....	2-28	2-110
Operation of Spare Wheel and Tire Assembly Carrier .....	3-8	3-21

**P**

Pintle Towing Procedures .....	2-25	2-107
PMCS Procedures, General .....	2-11	2-34
Portable Fire Extinguisher, Operate .....	2-30	2-114
Power Take-Off, Operate (All Except M915A2) .....	2-27	2-109
Preparation for Movement .....	2-34	2-118
Principles of Operation:		
Air Conditioning (All Except M915A2 and M916A1) .....	1-23	1-34
Air System .....	1-19	1-30
Brakes .....	1-20	1-30
Central Tire Inflation System (CTIS) (M917A1 and M917A1 w/MCS) .....	1-24	1-34
Cooling System .....	1-17	1-28
Drive Train .....	1-14	1-26
Electrical System .....	1-18	1-29
Exhaust System .....	1-16	1-28
Fuel System .....	1-15	1-27
Hydraulic System (All Except M915A2) .....	1-22	1-32
Steering .....	1-21	1-32

**R**

Rear Wheel and Tire Assembly Replacement (M917A1 and M917A1 w/MCS) .....	3-11	3-32
Refueling .....	3-6	3-18
Reporting Equipment Improvement Recommendations (EIRs) ..	1-5	1-3
Rifle Mounting Kit .....	2-32	2-117

*Subject* *Paragraph* *Page*

**S**

Sandy or Dusty Conditions, Operate in .....	2-43	2-134
Seat Controls .....	2-5	2-24
Self-Tests .....	2-13	2-82
Shut Down Engine .....	2-20	2-97.0
Slave Start Truck .....	2-36	2-122
Sliding Fifth Wheel:		
Operate M915A2 .....	2-21	2-98
Operate M916A1 and M916A2 .....	2-22	2-100
Snow and Ice, Operate on .....	2-45	2-136
Start Engine .....	2-14	2-85
Steering Wheel and Column-Mounted Controls .....	2-3	2-20
Steering, Principles of Operation .....	1-21	1-32

**T**

Tips, Driving .....	2-18	2-93
Tire Inflation, Manual .....	3-7	3-19
Tow Truck .....	2-37	2-123
Transfer Case (All Except M915A2), Operate .....	2-16	2-88
Transmission, Operate .....	2-15	2-87
Troubleshooting Symptom Index .....	3-4	3-4

**U**

Uncouple From Truck (All Except M917A1 and M917A1 w/MCS) .....	2-24	2-105
---	------	-------

**W**

Warranty Information .....	1-6	1-3
Wheel and Tire Assembly Replacement (All Except M917A1 and M917A1 w/MCS) .....	3-9	3-23
Winch Controls (M916A1 and M916A2) .....	2-7	2-29
Winch, Operate (M916A1 and M916A2) .....	2-28	2-110
Woods or Rocky Terrain, Operate in .....	2-44	2-135

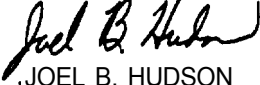




By Order of the Secretary of the Army:

DENNIS J. REIMER  
*General, United States Army*  
*Chief of Staff*

Official:

  
JOEL B. HUDSON  
*Administrative Assistant to the*  
*Secretary of the Army*  
04419

Distribution:

To be distributed in accordance with IDN number 380850, Operator maintenance requirements for TM9-2320-363-10.



RECOMMENDED CHANGES TO EQUIPMENT TECHNICAL PUBLICATIONS

BE EXACT... PIN-POINT WHERE IT IS				IN THIS SPACE TELL WHAT IS WRONG AND WHAT SHOULD BE DONE ABOUT IT:
PAGE NO	PARA-GRAPH	FIGURE NO	TABLE NO	
2-44	2-5		2-2	Item 1. Item reads: break pedal (1) Should read: brake pedal (1)



THEN... JOT DOWN THE DOPE ABOUT IT ON THIS FORM. CAREFULLY TEAR IT OUT. FOLD IT AND DROP IT IN THE MAIL!

**SOMETHING WRONG WITH THIS PUBLICATION?**

FROM: (PRINT YOUR UNIT'S COMPLETE ADDRESS)

Your Mailing Address

DATE SENT

Date you filled out this form

PUBLICATION NUMBER

TM 9-2320-363-10

PUBLICATION DATE

Date of TM

PUBLICATION TITLE

Operator's Manual

PRINTED NAME, GRADE OR TITLE, AND TELEPHONE NUMBER

Your Name, Rank, and Phone Number

SIGN HERE

DA FORM 2028-2  
1 JUL 79

PREVIOUS EDITIONS ARE OBSOLETE.

P.S.--IF YOUR OUTFIT WANTS TO KNOW ABOUT YOUR RECOMMENDATION MAKE A CARBON COPY OF THIS AND GIVE IT TO YOUR HEADQUARTERS

SAMPLE

FILL IN YOUR  
UNIT'S ADDRESS

FOLD BACK

DEPARTMENT OF THE ARMY

POSTAGE AND FEES PAID  
DEPARTMENT OF THE ARMY  
OOD 314




OFFICIAL BUSINESS  
PENALTY FOR PRIVATE USE \$300

**SAMPLE**

Commander  
U.S. Army Tank-automotive  
and Armaments Command  
ATTN: AMSTA-AC-NML  
Rock Island, IL 61201-9948

TEAR ALONG PERFORATED LINE

RECOMMENDED CHANGES TO EQUIPMENT TECHNICAL PUBLICATIONS



THEN... JOT DOWN THE DOPE ABOUT IT ON THIS FORM. CAREFULLY TEAR IT OUT. FOLD IT AND DROP IT IN THE MAIL.

## SOMETHING WRONG

WITH THIS PUBLICATION?

FROM: (PRINT YOUR UNIT'S COMPLETE ADDRESS)

---

DATE SENT

PUBLICATION NUMBER

**TM 9-2320-363-10**

PUBLICATION DATE

30 Dec 97

PUBLICATION TITLE

**Operator's Manual**

BE EXACT. PIN-POINT WHERE IT IS				IN THIS SPACE TELL WHAT IS WRONG AND WHAT SHOULD BE DONE ABOUT IT:
PAGE NO	PARA-GRAPH	FIGURE NO	TABLE NO	

PRINTED NAME, GRADE OR TITLE, AND TELEPHONE NUMBER

SIGN HERE:

DA FORM 2028-2  
1 JUL 79

PREVIOUS EDITIONS ARE OBSOLETE.

P.S.—IF YOUR OUTFIT WANTS TO KNOW ABOUT YOUR RECOMMENDATION MAKE A CARBON COPY OF THIS AND GIVE IT TO YOUR HEADQUARTERS.

FILL IN YOUR  
UNITS ADDRESS



DEPARTMENT OF THE ARMY

OFFICIAL BUSINESS



NO POSTAGE  
NECESSARY  
IF MAILED  
IN THE  
UNITED STATES

**BUSINESS REPLY MAIL**  
FIRST CLASS PERMIT NO. 82 ROCK ISLAND IL

POSTAGE WILL BE PAID BY ROCK ISLAND ARSENAL




Director  
Armament and Chemical Acquisition  
and Logistics Activity  
ATTN: AMSTA-AC-NML  
Rock Island, IL 61201-9948



TEAR ALONG PERFORATED LINE

RECOMMENDED CHANGES TO EQUIPMENT TECHNICAL PUBLICATIONS



THEN... JOT DOWN THE DOPE ABOUT IT ON THIS FORM. CAREFULLY TEAR IT OUT. FOLD IT AND DROP IT IN THE MAIL!

## SOMETHING WRONG

WITH THIS PUBLICATION?

FROM: (PRINT YOUR UNIT'S COMPLETE ADDRESS)

---

DATE SENT

PUBLICATION NUMBER

**TM 9-2320-363-10**

PUBLICATION DATE

30 Dec 97

PUBLICATION TITLE

**Operator's Manual**

BE EXACT. PIN-POINT WHERE IT IS				IN THIS SPACE TELL WHAT IS WRONG AND WHAT SHOULD BE DONE ABOUT IT:
PAGE NO	PARA-GRAPH	FIGURE NO	TABLE NO	

PRINTED NAME, GRADE OR TITLE, AND TELEPHONE NUMBER

SIGN HERE

DA FORM 2028-2  
JUL 79

PREVIOUS EDITIONS ARE OBSOLETE.

P.S.--IF YOUR OUTFIT WANTS TO KNOW ABOUT YOUR RECOMMENDATION MAKE A CARBON COPY OF THIS AND GIVE IT TO YOUR HEADQUARTERS.

FILL IN YOUR  
UNITS ADDRESS



DEPARTMENT OF THE ARMY

OFFICIAL BUSINESS



NO POSTAGE  
NECESSARY  
IF MAILED  
IN THE  
UNITED STATES

**BUSINESS REPLY MAIL**  
FIRST CLASS      PERMIT NO. 82      ROCK ISLAND IL

POSTAGE WILL BE PAID BY ROCK ISLAND ARSENAL




**Director  
Armament and Chemical Acquisition  
and Logistics Activity  
ATTN: AMSTA-AC-NML  
Rock Island, IL 61201-9948**



TEAR ALONG PERFORATED LINE



RECOMMENDED CHANGES TO EQUIPMENT TECHNICAL PUBLICATIONS



## SOMETHING WRONG WITH THIS PUBLICATION?

FROM: (PRINT YOUR UNIT'S COMPLETE ADDRESS)

---

DATE SENT

PUBLICATION NUMBER

PUBLICATION DATE

PUBLICATION TITLE

**TM 9-2320-363-10**      30 Dec 97      **Operator's Manual**

BE EXACT... PIN-POINT WHERE IT IS				IN THIS SPACE TELL WHAT IS WRONG AND WHAT SHOULD BE DONE ABOUT IT:
PAGE NO	PARA-GRAPH	FIGURE NO	TABLE NO	

PRINTED NAME, GRADE OR TITLE, AND TELEPHONE NUMBER

SIGN HERE

DA FORM 2028-2  
1 JUL 79

PREVIOUS EDITIONS ARE OBSOLETE.

P.S.—IF YOUR OUTFIT WANTS TO KNOW ABOUT YOUR RECOMMENDATION MAKE A CARBON COPY OF THIS AND GIVE IT TO YOUR HEADQUARTERS.

FILL IN YOUR  
UNITS ADDRESS



DEPARTMENT OF THE ARMY

OFFICIAL BUSINESS



NO POSTAGE  
NECESSARY  
IF MAILED  
IN THE  
UNITED STATES

**BUSINESS REPLY MAIL**

FIRST CLASS      PERMIT NO. 82      ROCK ISLAND IL

POSTAGE WILL BE PAID BY ROCK ISLAND ARSENAL



Director  
Armament and Chemical Acquisition  
and Logistics Activity  
ATTN: AMSTA-AC-NML  
Rock Island, IL 61201-9948



TEAR ALONG PERFORATED LINE



**PIN: 069047-000**